

## 8-12GHz Driver Amplifier

### GaAs Monolithic Microwave IC

#### Description

The CHA6105 is a monolithic three-stage medium power amplifier designed for X-band applications.

The driver provides typically 31.5dBm output power at saturation and is suitable for systems requiring a high compression level. Moreover it includes a biasing control circuit that makes Pout less sensitive to spread and chip environment.

The circuit is manufactured with a pHEMT process, 0.25µm gate length, via holes through the substrate, air bridges and electron beam gate lithography.

It is available in chip form.

#### Main Features

- Frequency range: 8-12GHz
- 31.5dBm Saturated output power
- 30dB Linear Gain
- Quiescent bias point: 8V@700mA
- Chip size: 2.80 x 2.21 x 0.07mm

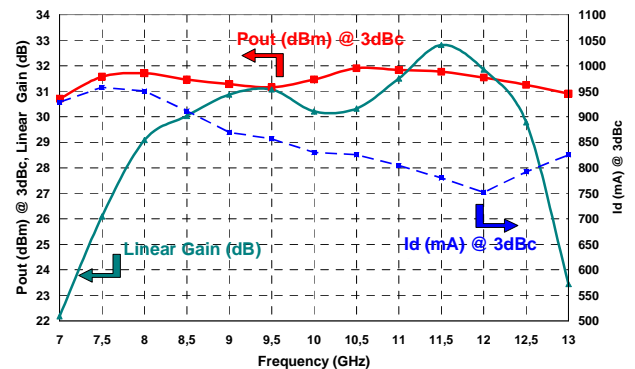
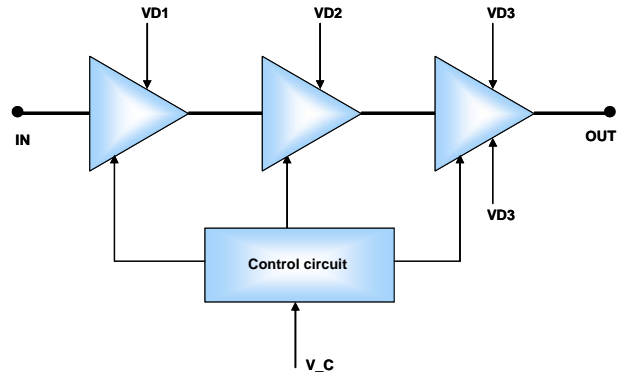

*Pout & Id @ 3dB gain compression and Linear Gain (Pulse 25µs 10% Tamb. 20°C)*

#### Main Characteristics

Tamb = +20°C, Vc = +8V (Pulse 25µs 10%)

Symbol	Parameter	Min	Typ	Max	Unit
Fop	Operating frequency range	8		12	GHz
G	Small signal gain		30		dB
Psat	Saturated output power		31.5		dBm
Idq	Power supply quiescent current		700		mA

ESD Protections: Electrostatic discharge sensitive device observe handling precautions!

## Electrical Characteristics

Vd = +8V, Pulse 25µs 10%

Symbol	Parameter	Min	Typ	Max	Unit
Top	Operating temperature range	-40		85	°C
Fop	Operating frequency range	8		12	GHz
G	Small signal gain at 25°C	25.5	30	34	dB
ΔG_T	Linear gain variation vs temperature at 25°C		-0.03 5		dB/°C
P1dB	Output power at 1dB gain compression at 25°C		30.5		dBm
P3dB	Output power at 3dB gain compression at 25°C	29.5	31		dBm
Psat	Output power at saturation		31.5		dBm
dBS11	Input Return Loss		2:1		dB
dBS22	Output Return Loss		2:1		dB
Vd	Power supply voltage		8		V
Idq	Power supply quiescent current		700		mA
Id_3dBc	Consumption under 3dB gain compression		925	1150	mA
V_c	Drain current control voltage		-5		V
I_c	Biasing circuit consumption		25		mA

## Absolute Maximum Ratings (1)

Tamb = 20°C

Symbol	Parameter	Values	Unit
Pin_max	Maximum RF input power	13	dBm
Cmp	Compression level	13	dB
Vd	Power supply voltage	9	V
<Id>	maximum value of CW power supply current	850	mA
V_c	Drain current control voltage	-6	V
Tj	Maximum Junction temperature	175	°C
Tstg	Storage temperature range	-55 to +125	°C

(1) Operation of this device above anyone of these parameters may cause permanent damage

**Typical measurement characteristics**

**Measurements**

Vd = 8V; Vctrl = -5V (Id Quiescent = 700mA). Pulsed = 25µs 10%

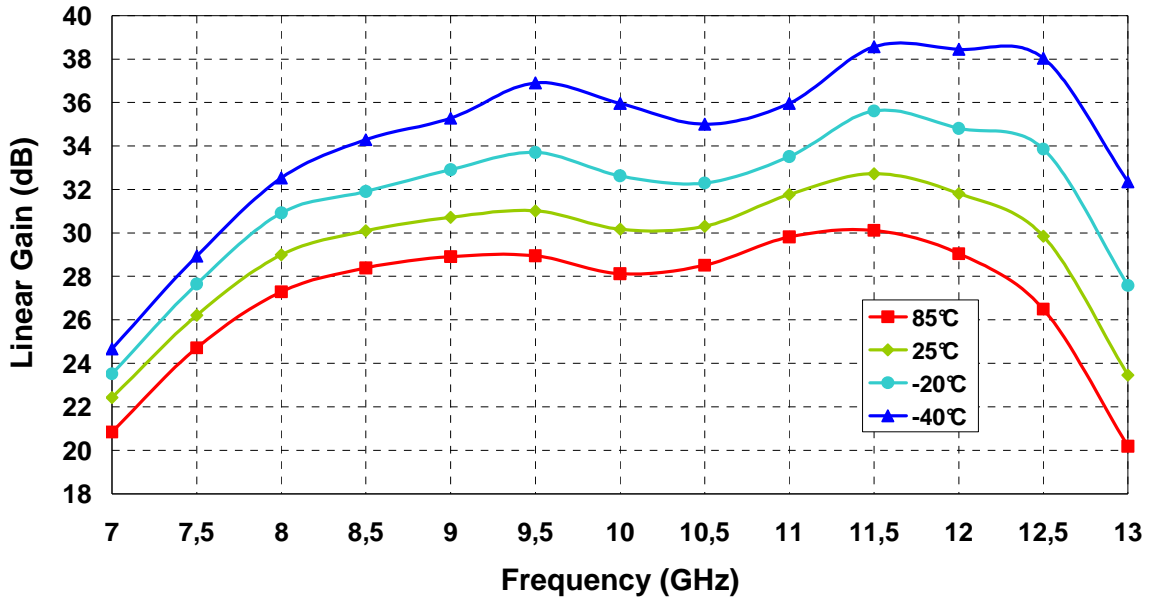

*Linear gain vs frequency and temperature*

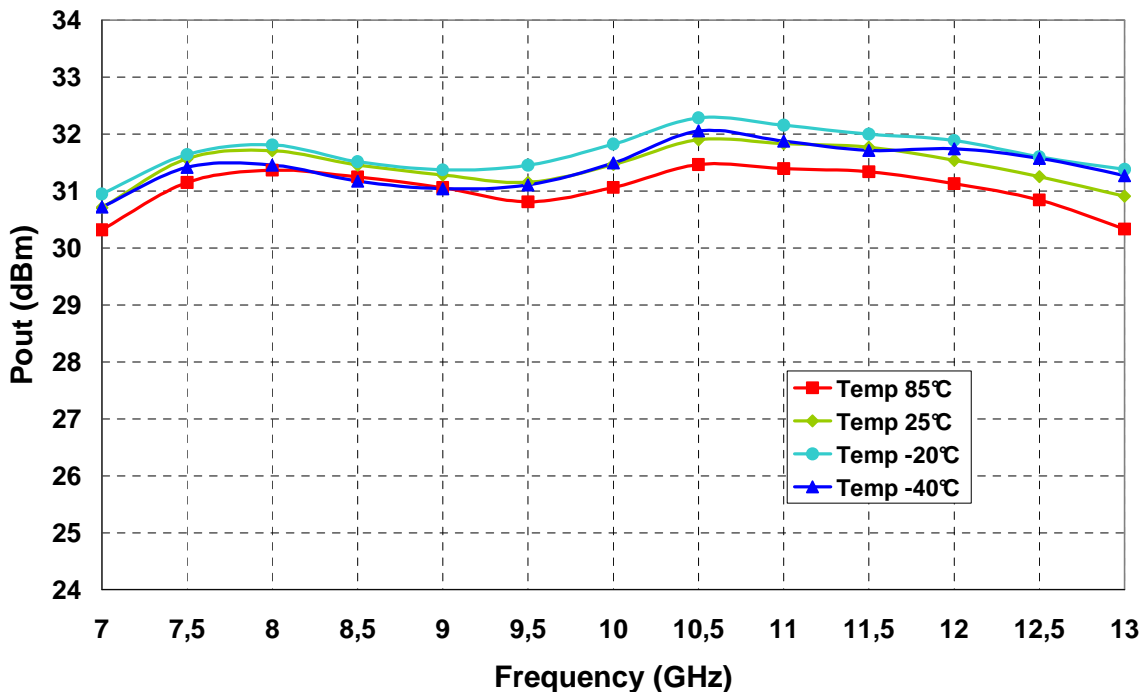

*Output Power @ 3dB gain compression vs frequency and temperature*

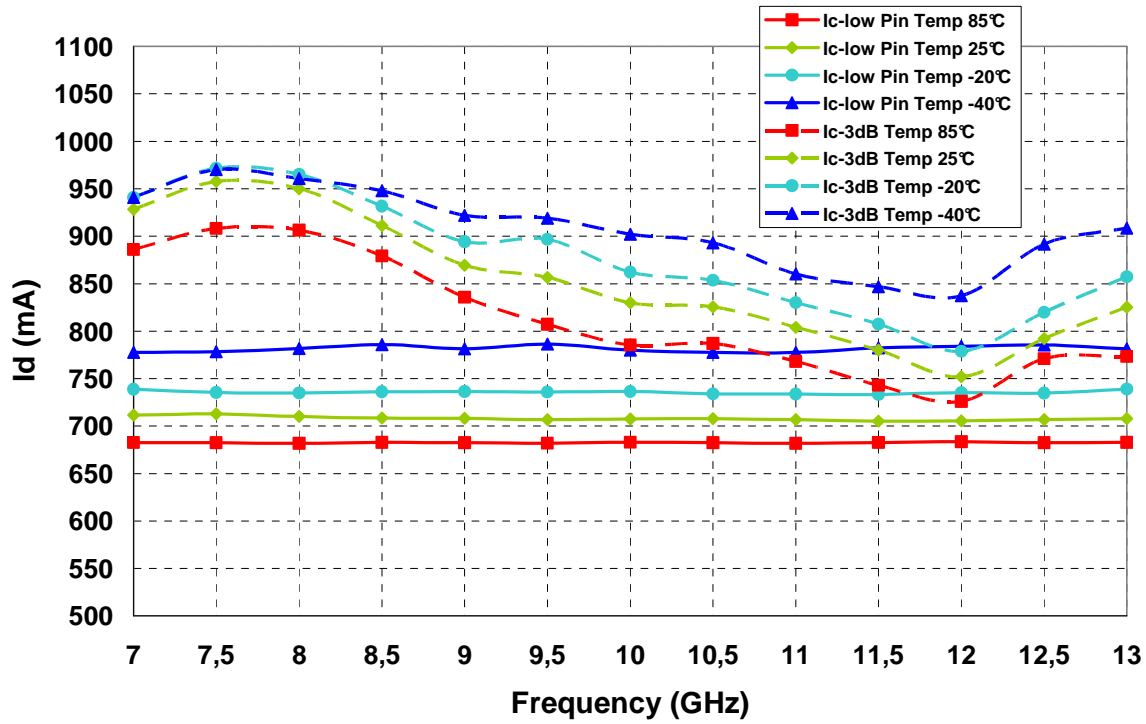

Drain current @ low Pin and @ 3dB gain compression vs frequency and temperature

Tamb = 25°C, Vd = 8V; Vctrl = -5V (Id Quiescent = 7 00mA). Pulsed = 25µs 10%

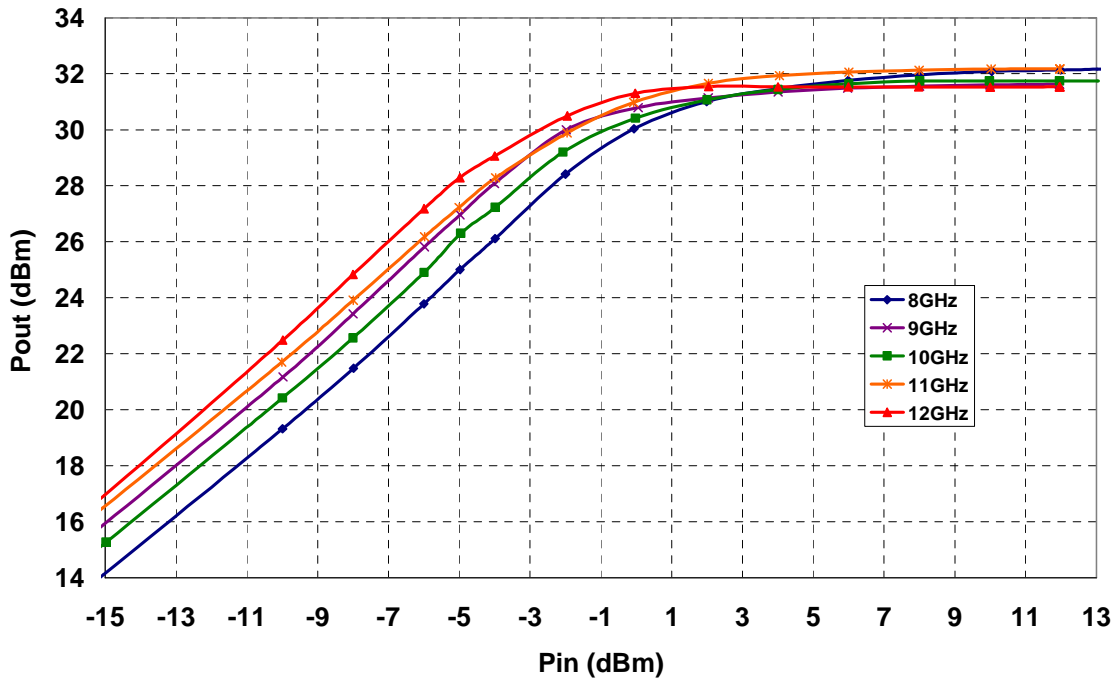

Output power vs Input power

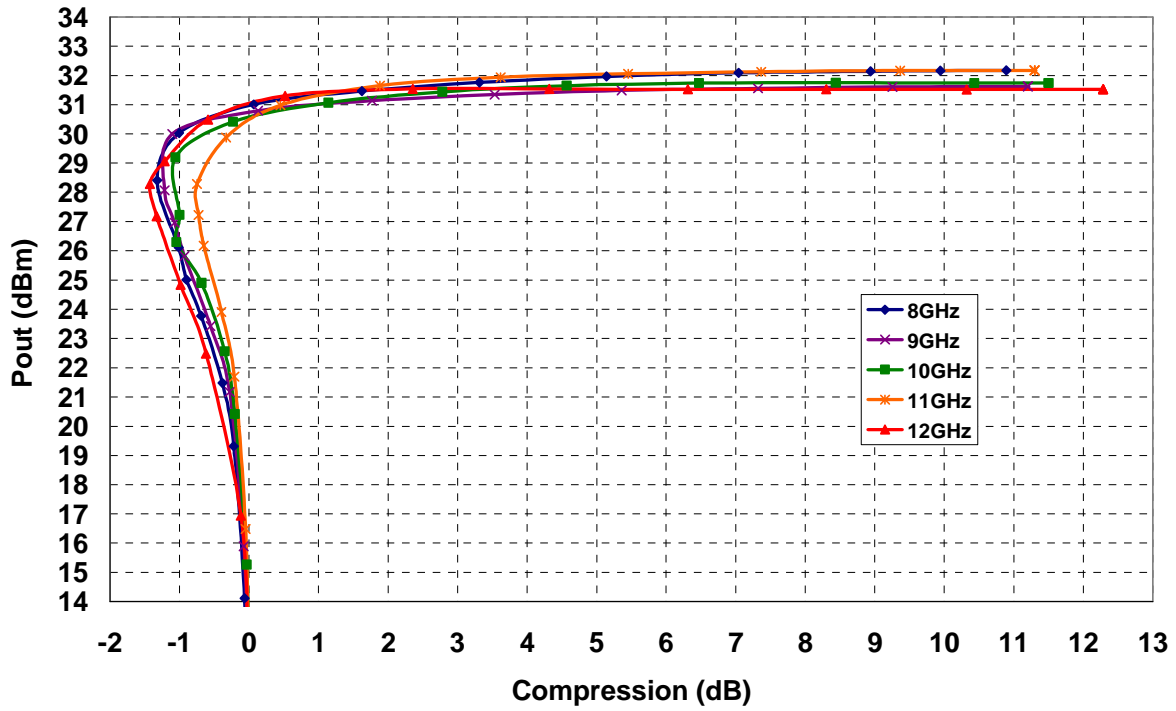

Output power vs Gain compression

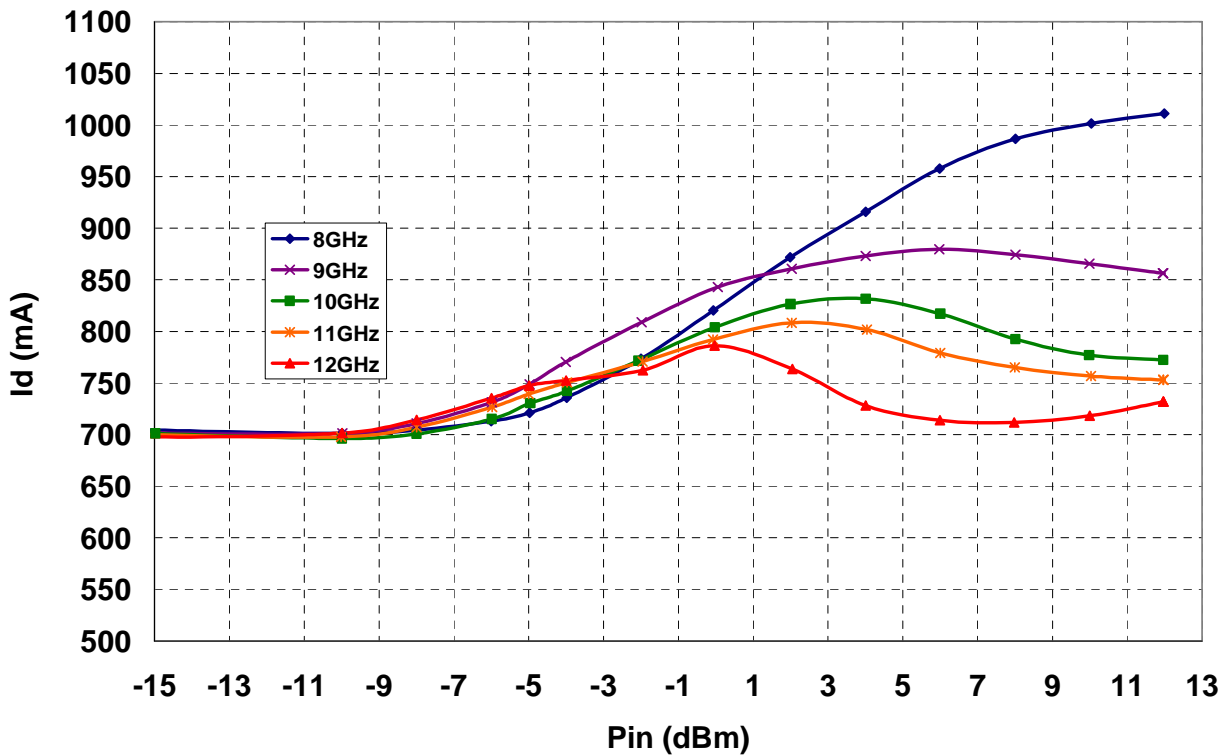

Drain current vs Input power

## Chip Mechanical Data and Pin references

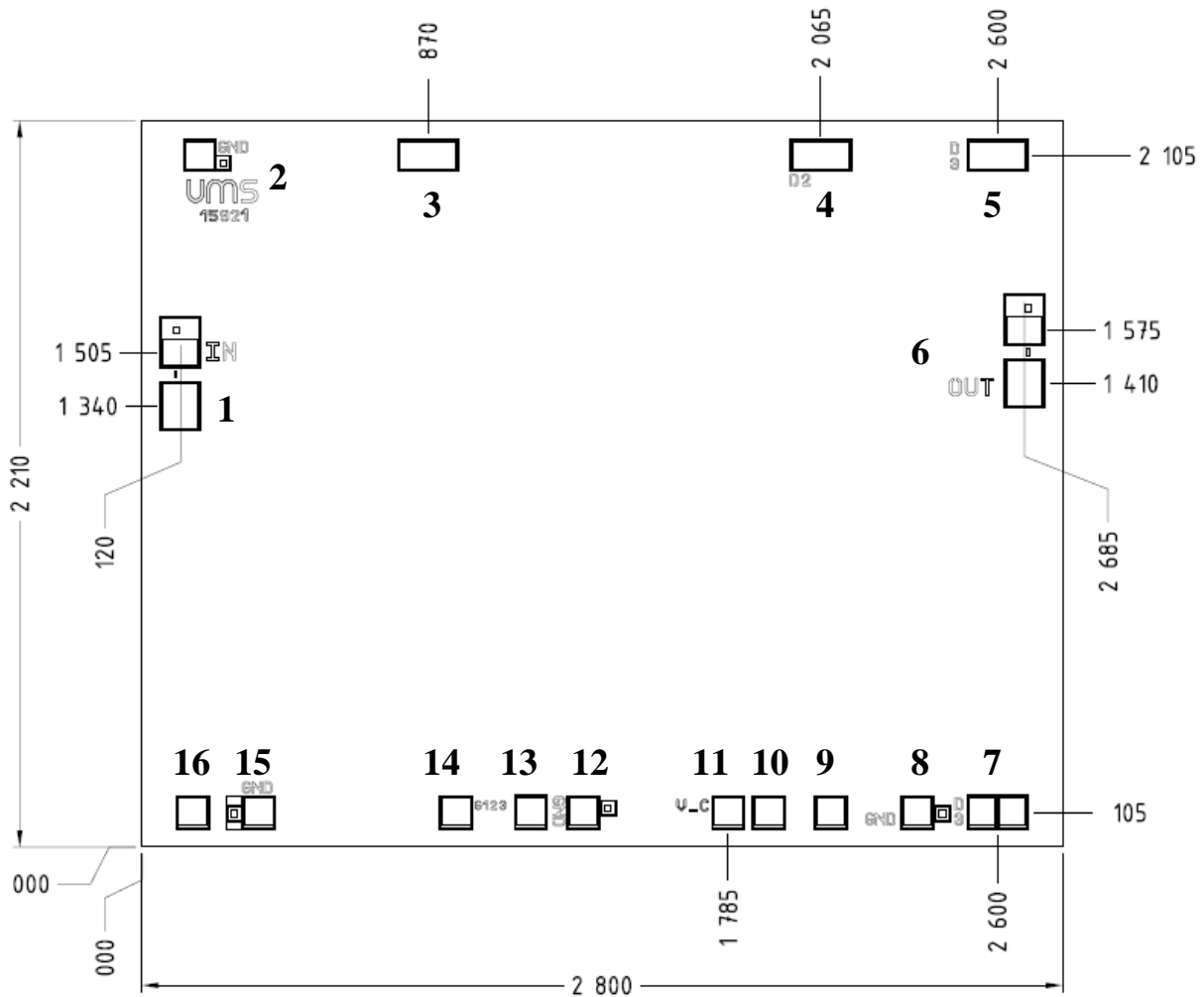

UNITS :  $\mu\text{m}$   
Tol :  $\pm 35\mu\text{m}$

Chip thickness =  $70\mu\text{m} \pm 10\mu\text{m}$

RF pads (1, 6) =  $122 \times 150\mu\text{m}^2$

DC pads (2, 8, 9, 10, 11, 12, 13, 14, 15, 16) =  $100 \times 100\mu\text{m}^2$

DC pads (3, 4, 5, 7) =  $186 \times 100\mu\text{m}^2$

Pin number	Pin name	Description
1	IN	Input RF
11	V_C	Control Voltage
14	GR	Not used
2, 8, 12, 15	GND	Ground (NC)
9, 10, 13, 16	-	Not Used
3, 4, 5, 7	VD	Drain supply voltage
6	OUT	Output RF

**Assembly recommendations in test fixture**

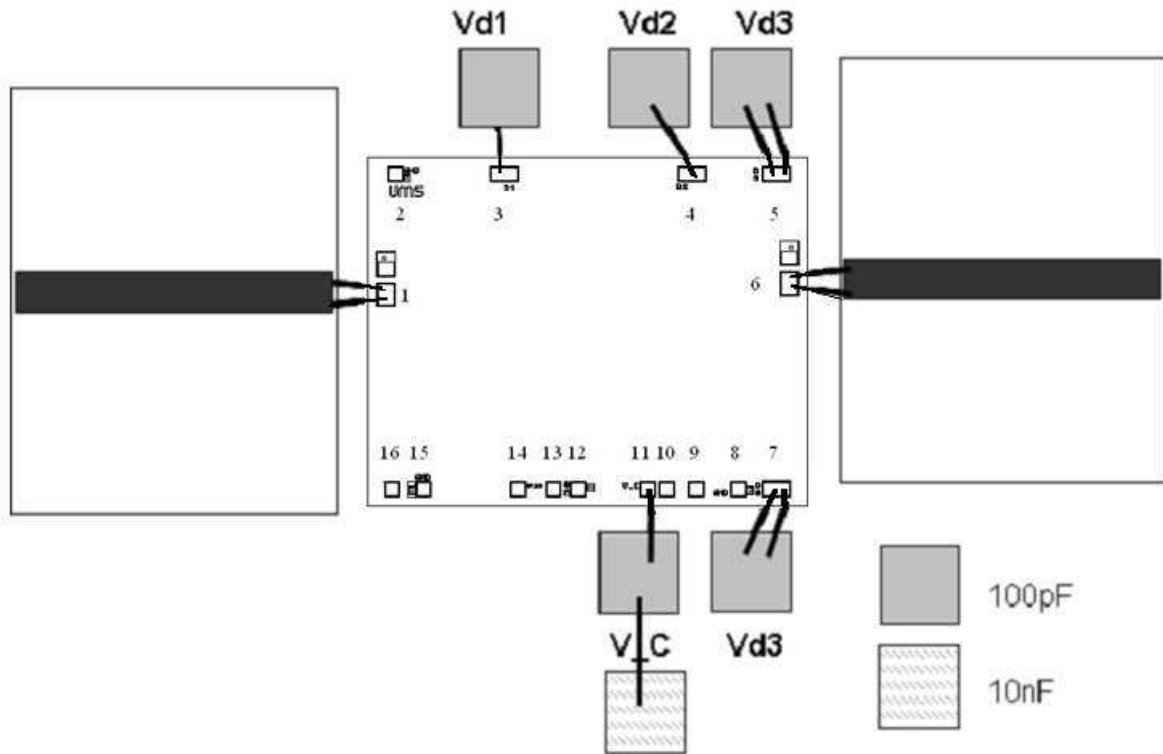

## Recommended ESD management

Refer to the application note AN0020 available at <http://www.ums-gaas.com> for ESD sensitivity and handling recommendations for the UMS products.

## Ordering Information

Chip form : CHA6105-99F/00

Information furnished is believed to be accurate and reliable. However **United Monolithic Semiconductors S.A.S.** assumes no responsibility for the consequences of use of such information nor for any infringement of patents or other rights of third parties which may result from its use. No license is granted by implication or otherwise under any patent or patent rights of **United Monolithic Semiconductors S.A.S.** Specifications mentioned in this publication are subject to change without notice. This publication supersedes and replaces all information previously supplied. **United Monolithic Semiconductors S.A.S.** products are not authorised for use as critical components in life support devices or systems without express written approval from **United Monolithic Semiconductors S.A.S.**