

24-30GHz Integrated Down Converter

GaAs Monolithic Microwave IC

Description

The CHR2295 is a multifunction chip which integrates a LO time two multiplier, a balanced cold FET mixer, and a RF LNA. It is designed for a wide range of applications, typically commercial communication systems. The backside of the chip is both RF and DC grounds. This helps simplify the assembly process.

The circuit is manufactured with a pHEMT process, 0.25µm gate length, via holes through the substrate, air bridges and electron beam gate lithography. It is available in chip form.

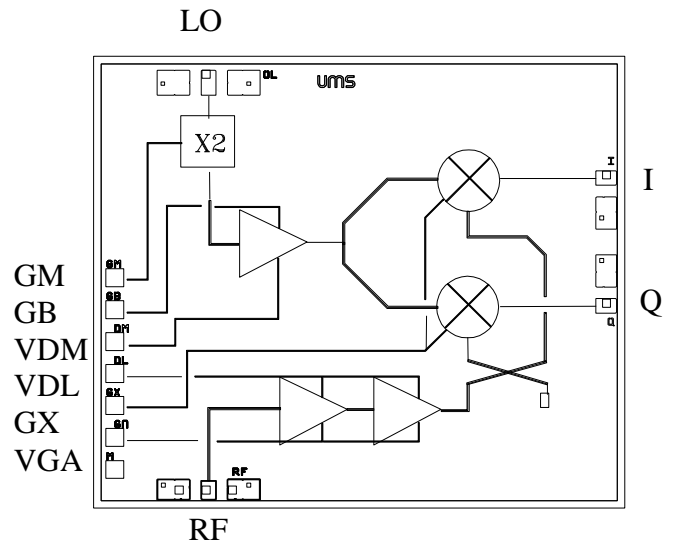

Main Features

- Broadband performances: 24-30GHz
- 11dB conversion gain
- 3.5dB noise figure, for IF>0.1GHz
- 10dBm LO input power
- -10dBm RF IP@1dB gain comp.
- Low DC power: 120mA@3.5V
- Chip size: 2.49x1.97x0.10mm

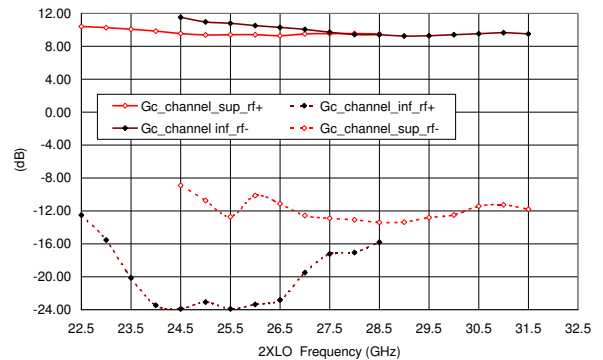

Conversion Gain & Image suppression @IF=1.5GHz (test board losses included)

Main Characteristics

Tamb. = 25°C

Symbol	Parameter	Min	Typ	Max	Unit
F _{RF}	RF frequency range	24		30	GHz
F _{LO}	LO frequency range	12		15	GHz
F _{IF}	IF frequency range	DC		1.5	GHz
G _c	Conversion gain	8.5	11		dB

ESD Protection: Electrostatic discharge sensitive device. Observe handling precautions!

Electrical Characteristics for Broadband Operation

Tamb = +25°C, Vd = 3.5V

Symbol	Parameter	Min	Typ	Max	Unit
F _{RF}	RF frequency range	24		30	GHz
F _{LO}	LO frequency range	12		15	GHz
F _{IF}	IF frequency range	DC		1.5	GHz
G _c	Conversion gain ⁽¹⁾	8.5	11		dB
NF	Noise Figure, for IF>0.1GHz		3.5		dB
P _{LO}	LO Input power		10		dBm
Img Sup	Image Suppression	15	17		dBc
P1dB	Input power at 1dB gain compression		-10		dBm
LO VSWR	Input LO VSWR ⁽¹⁾		2.0:1		
RF VSWR	Input RF VSWR ⁽¹⁾		3.0:1		
I _d	Bias current ⁽²⁾		120		mA

(1) On Wafer measurements

(2) Current source biasing network is recommended. Optimum performances will be achieved for I_{dm}=50mA and I_{dl}=70mA

Absolute Maximum Ratings

Tamb. = 25°C ⁽¹⁾

Symbol	Parameter	Values	Unit
V _d	Drain bias voltage	4.0	V
I _d	Drain bias current	200	mA
V _g	Gate bias voltage	-2.0 to +0.4	V
P _{in}	Maximum peak input power overdrive ⁽²⁾	+15	dBm
T _a	Operating temperature range	-40 to +85	°C
T _{stg}	Storage temperature range	-55 to +155	°C

(1) Operation of this device above anyone of these parameters may cause permanent damage.

(2) Duration < 1s.

Typical On-wafer Measurements

Bias Conditions : $V_{dm} = V_{dl} = 3.5V$, $V_{gm} = -0.9V$, $V_{gb} = -0.3V$, $V_{gx} = -0.7V$, $V_{ga} = -0.2V$

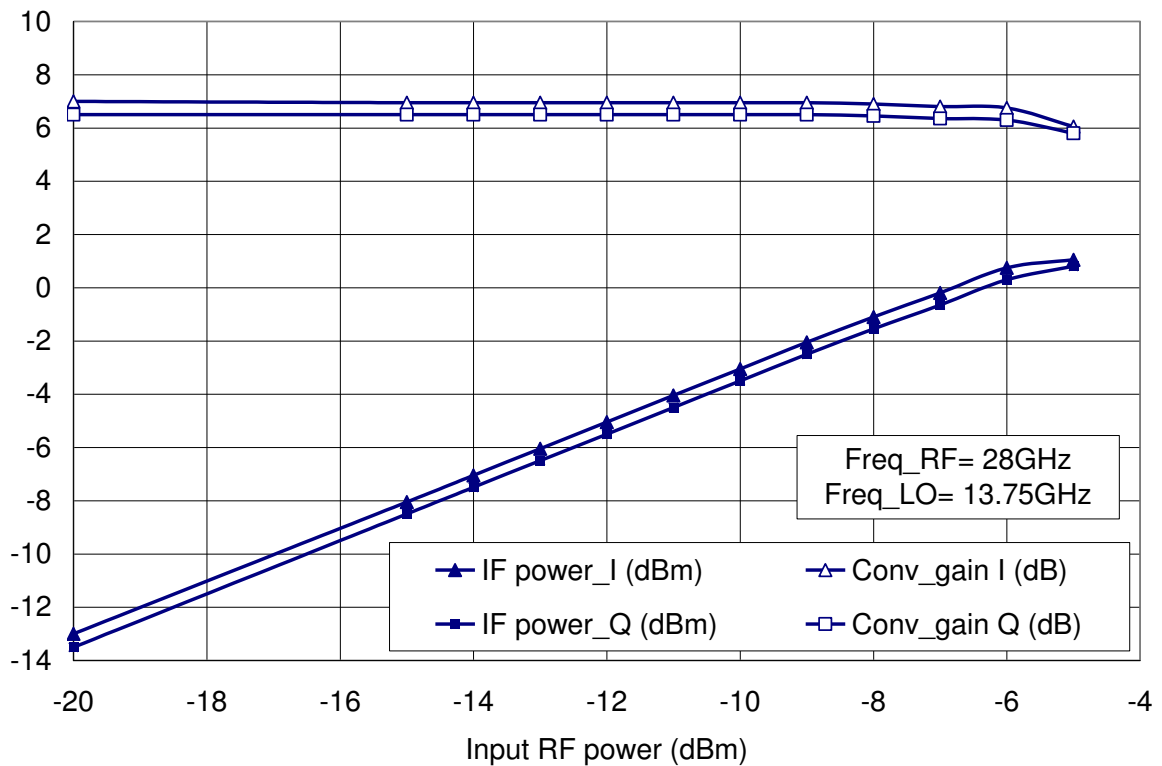
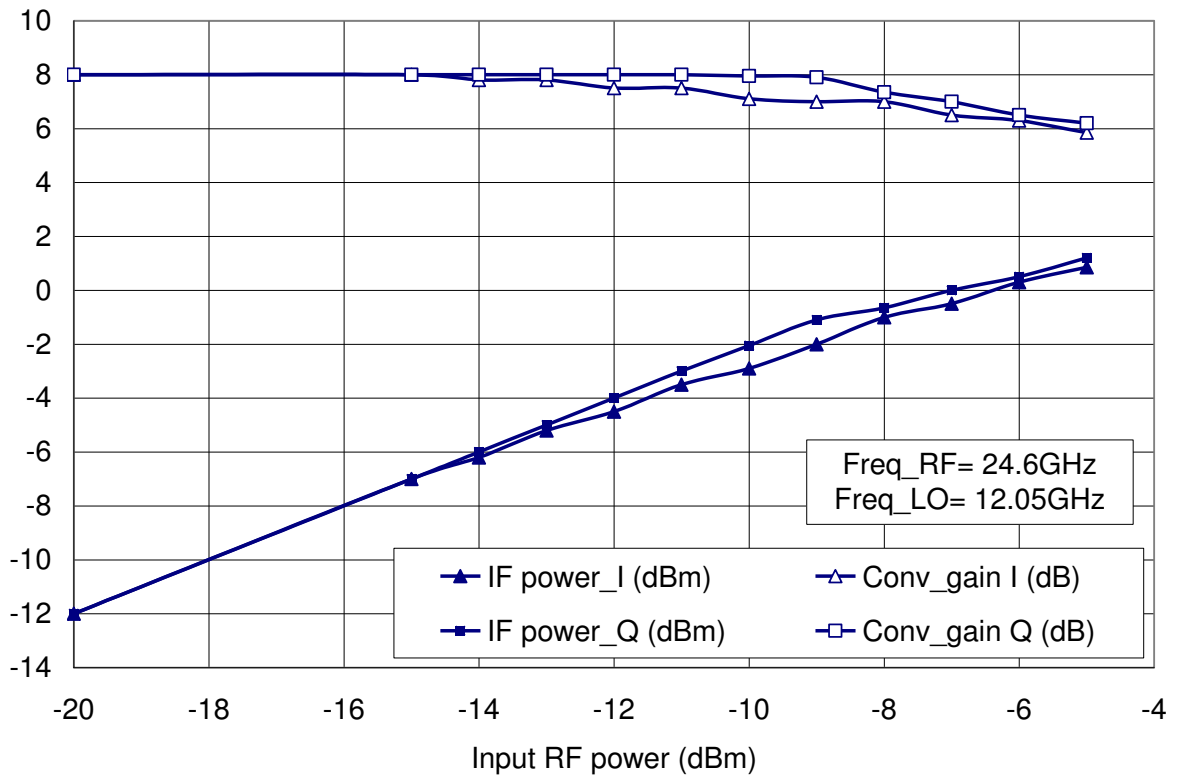

Input RF compression by channel

Typical On-board Measurements

Bias Conditions : $V_{dm} = V_{dl} = 3.5V$, $V_{gm} = V_{gx} = -0.9V$, $V_{gb} = V_{ga} = -0.3V$

All these measurements include the losses from the test board (typically 1dB for the conversion gain and 0.5dB for the Noise Figure).

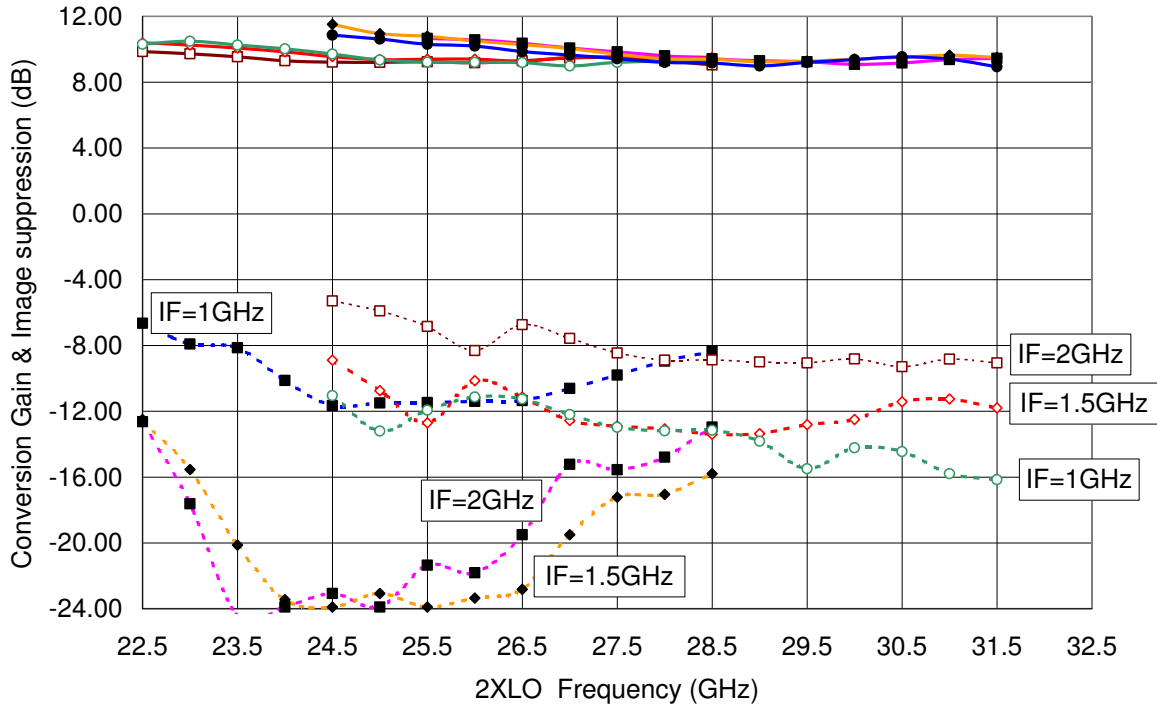

Conversion gain & Image suppression versus IF frequency

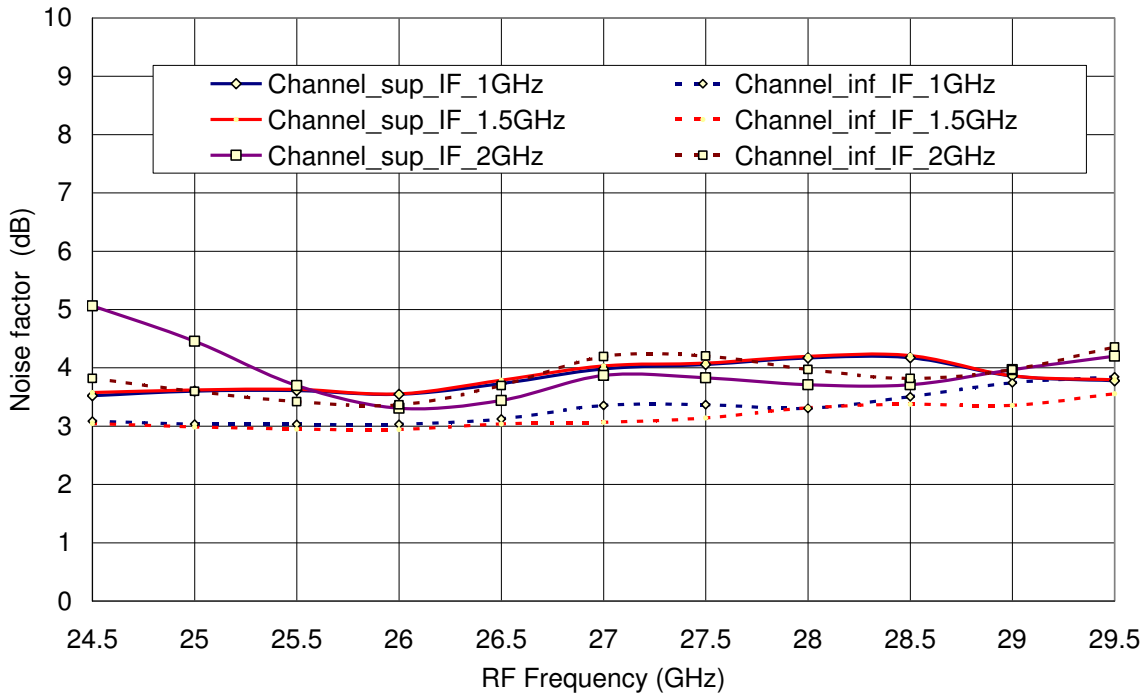

Noise figure supradyne & infradyne versus IF frequency

Chip Assembly and Mechanical Data

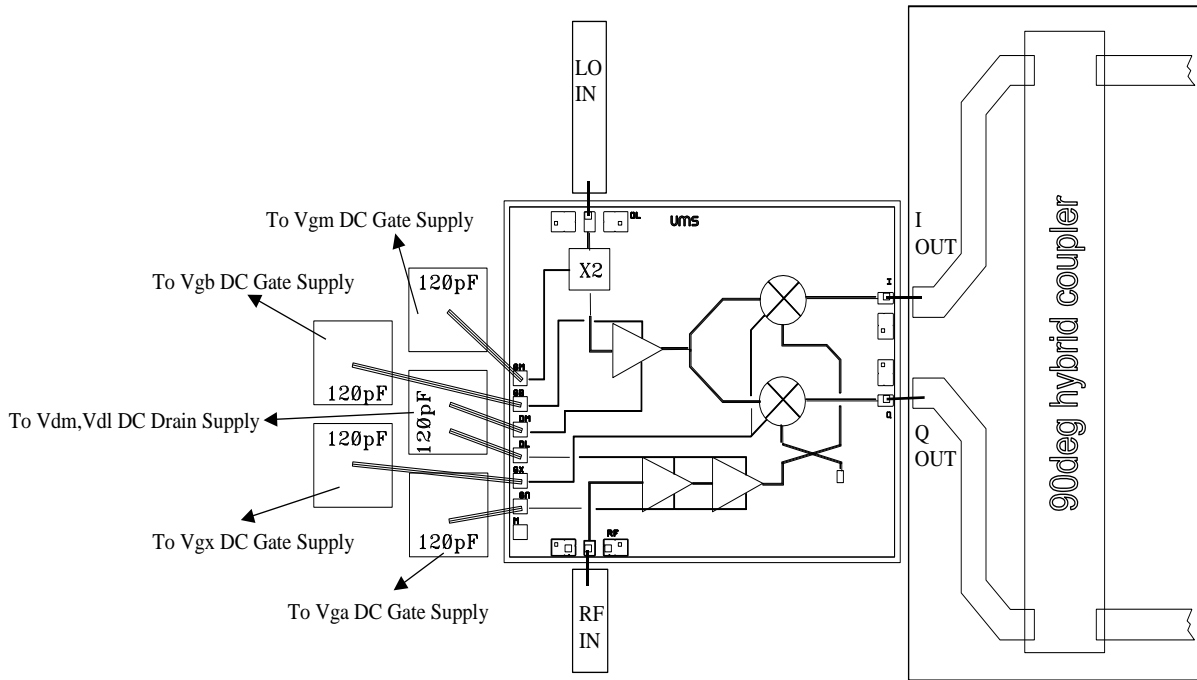

Note: Supply feed should be bypassed. 25µm diameter gold wire is recommended

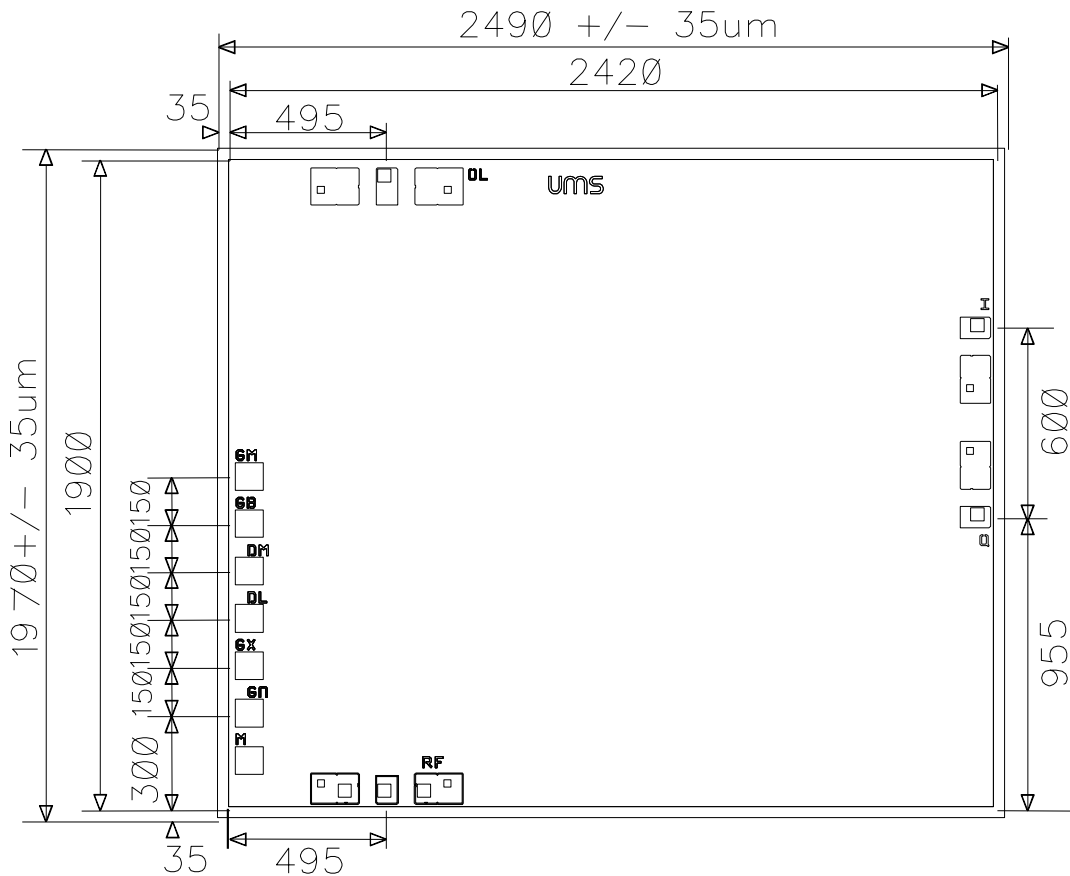

Bonding pad positions
(Chip thickness: 100µm. All dimensions are in micrometers)

