

22-24.5GHz RX Multifunction

GaAs Monolithic Microwave IC in SMD leadless package

Description

The CHR2411-QDG is a monolithic multifunction in K-Band which integrates a low noise amplifier and a mixer generating an IF signal from DC to 1MHz. All the active devices are self biased on chip.

The circuit is manufactured with a standard GaAs pHEMT process, 0.25µm gate length, via holes through the substrate, air bridges and electron beam gate lithography.

It is available in a 24 leads RoHS compliant QFN4x4 package.

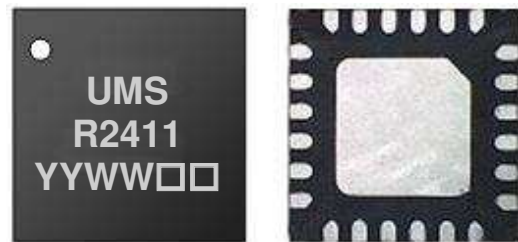

Plastic package

Main Features

- 22-24.5GHz Bandwidth
- 7dB Typical Noise figure
- 23dB ± 2.5dB Stable gain in temperature
- +5V single supply Voltage
- 24L-QFN4x4 SMD leadless package
- MSL1

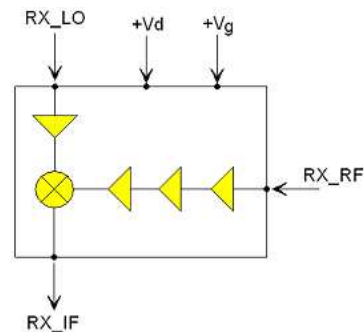

Multifunction block diagram

Main Electrical Characteristics

Tamb.= +25 °C

Symbol	Parameter	Min	Typ	Max	Unit
RF	Frequency range	22		24.5	GHz
Gc	Conversion Gain	19	23	27	dB
NF	SSB Noise figure (IF=1MHz)		7		dB
LO & RF	Input / Output Return Loss		-15	-8	dB

ESD Protection: Electrostatic discharge sensitive device. Observe handling precautions!

Electrical Characteristics

Tamb.= +25°C

Symbol	Parameter	Min	Typ	Max	Unit
RF	Frequency range	22		24.5	GHz
LO	Frequency range	22		24.5	GHz
IF	Frequency range	DC		1.0	MHz
RF	Return Loss		-15	-8	dB
LO	Return Loss		-15	-8	dB
IF	IF Load impedance		50		Ω
PLO	LO Drive Power	0	5		dBm
Gc	Conversion Gain	19	23	27	dB
ΔG(T)	Gain variation over Temperature		± 2.5		dB
NF	SSB Noise figure (IF=1MHz)		7		dB
P _{in} -1dB	Input Power at 1dB Gain Comp. @24GHz		-21		dBm
IP3_IN	Input IP3 @24GHz		-12		dBm
Iso	LO to RF Isolation		-45	-30	dB
+Vg, +Vd	Supply Voltage		5		V
+I	Supply Current		60	80	mA
Top	Operating temperature range	-40	25	105	°C

These performance has been obtained with the chip in QFN package mounted on the recommended boards (ref. 95541 & 95581) described in this document. These performances are highly dependent on this environment.

Absolute Maximum Ratings ⁽¹⁾

Tamb.= +25°C

Symbol	Parameter	Values	Unit
+Vg, +Vd	Maximum positive supply voltage	6	V
+I	Maximum positive supply voltage	90	mA
PLO	Maximum peak input power overdrive	8	dBm
PRF	Maximum peak input power overdrive	-12	dBm
Top	Operating temperature range	-40 to +105	°C
Tstg	Storage temperature range	-55 to +150	°C

⁽¹⁾ Operation of this device above anyone of these parameters may cause permanent damage.

Device thermal performances

All the figures given in this section are obtained assuming that the QFN device is cooled down only by conduction through the package thermal pad (no convection mode considered). The temperature is monitored at the package back-side interface (T_{case}) as shown below. The system maximum temperature must be adjusted in order to guarantee that T_{case} remains below the maximum value specified in the next table. So, the system PCB must be designed to comply with this requirement.

A derating must be applied on the dissipated power if the T_{case} temperature cannot be maintained below the maximum temperature specified (see the curve $P_{diss. Max}$) in order to guarantee the nominal device life time (MTTF).

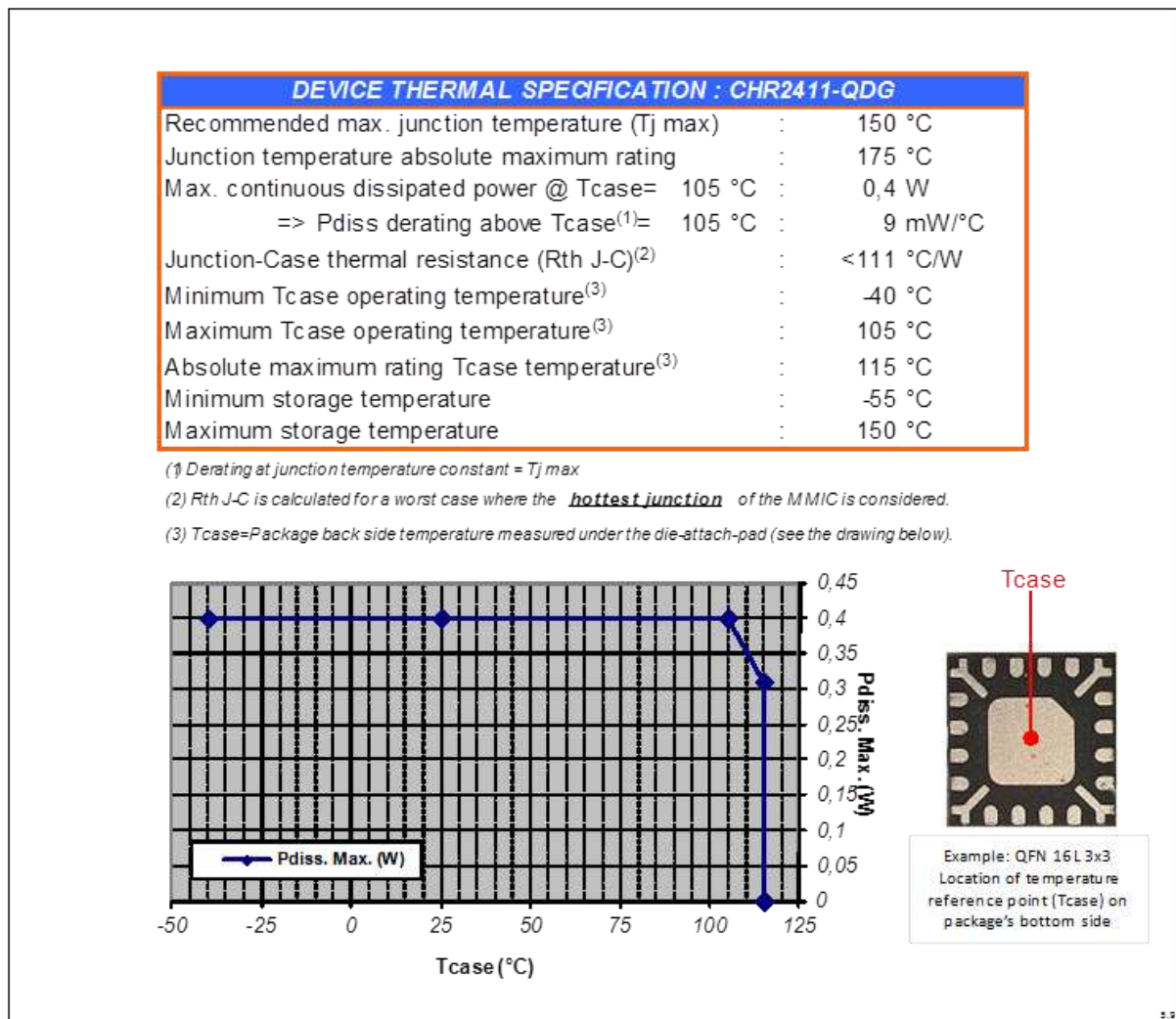

Typical QFN measurements on board 95541 (QFN access plans)

Conversion Gain versus Frequency (P_{LO} = 0dBm)

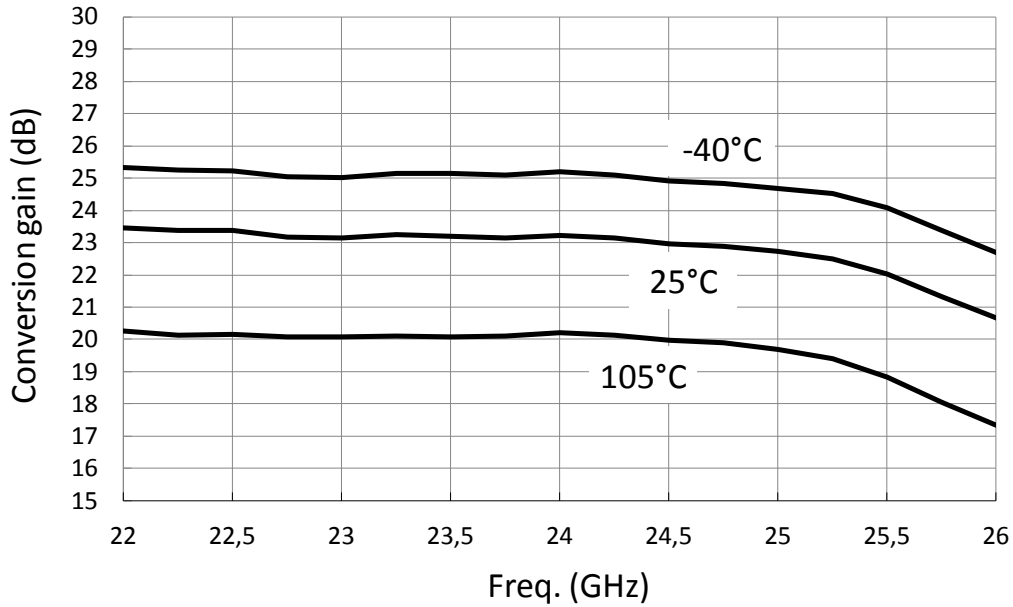

**Conversion Gain versus RF input Power
P_{LO} = 0dBm, F_{LO} = 24.25GHz**

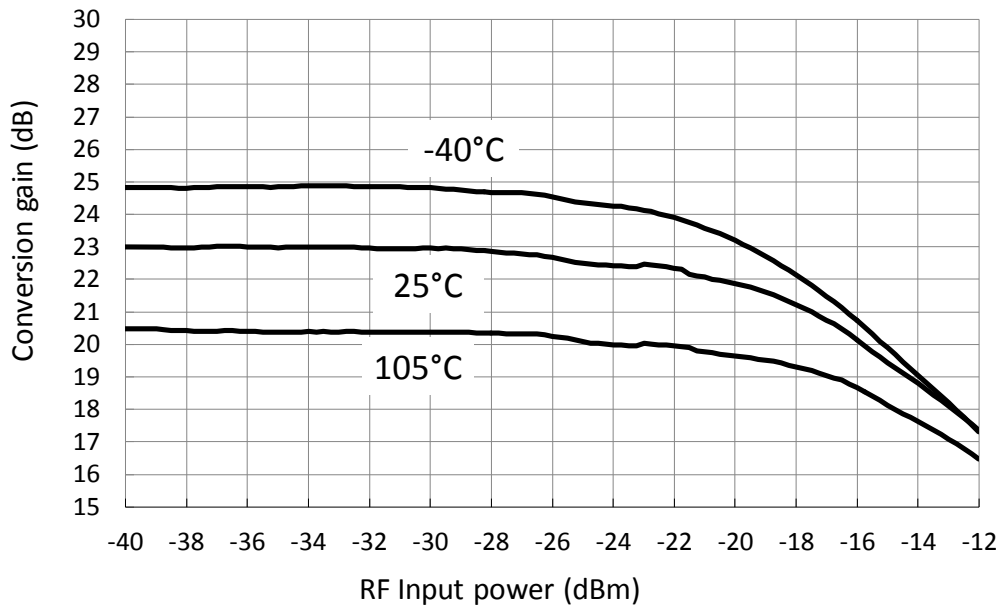

Package outline ⁽¹⁾

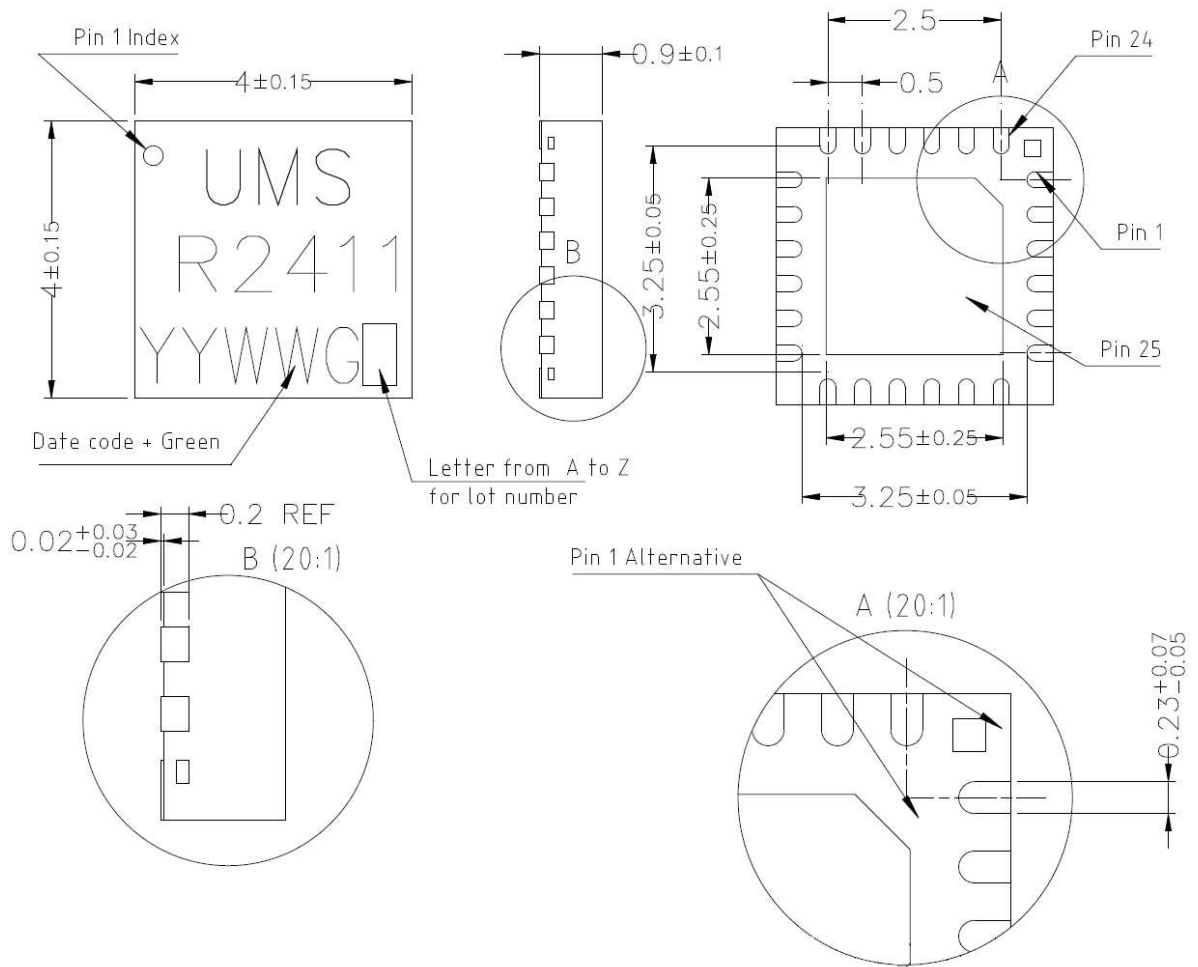

Matt tin, Lead Free	(Green)	1- Nc	9- Vg _{LNA}	17- Nc
Units :	mm	2- Nc	10- D1	18- Nc
From the standard :	JEDEC MO-220	3- Gnd ⁽²⁾	11- Vg _{Buffer}	19- Nc
	(VGGD)	4- RF in	12- Nc	20- IF out
	25- GND	5- Gnd ⁽²⁾	13- Nc	21- D2
		6- Nc	14- Gnd ⁽²⁾	22- D3
		7- Nc	15- LO in	23- Vd _{Buffer}
		8- Gnd ⁽²⁾	16- Gnd ⁽²⁾	24- Nc

⁽¹⁾ The package outline drawing included to this data-sheet is given for indication. Refer to the application note AN0017 (<http://www.ums-gaas.com>) for exact package dimensions.

⁽²⁾ It is strongly recommended to ground all pins marked “Gnd” through the PCB board. Ensure that the PCB board is designed to provide the best possible ground to the package.

External Components and bias configuration (recommended)

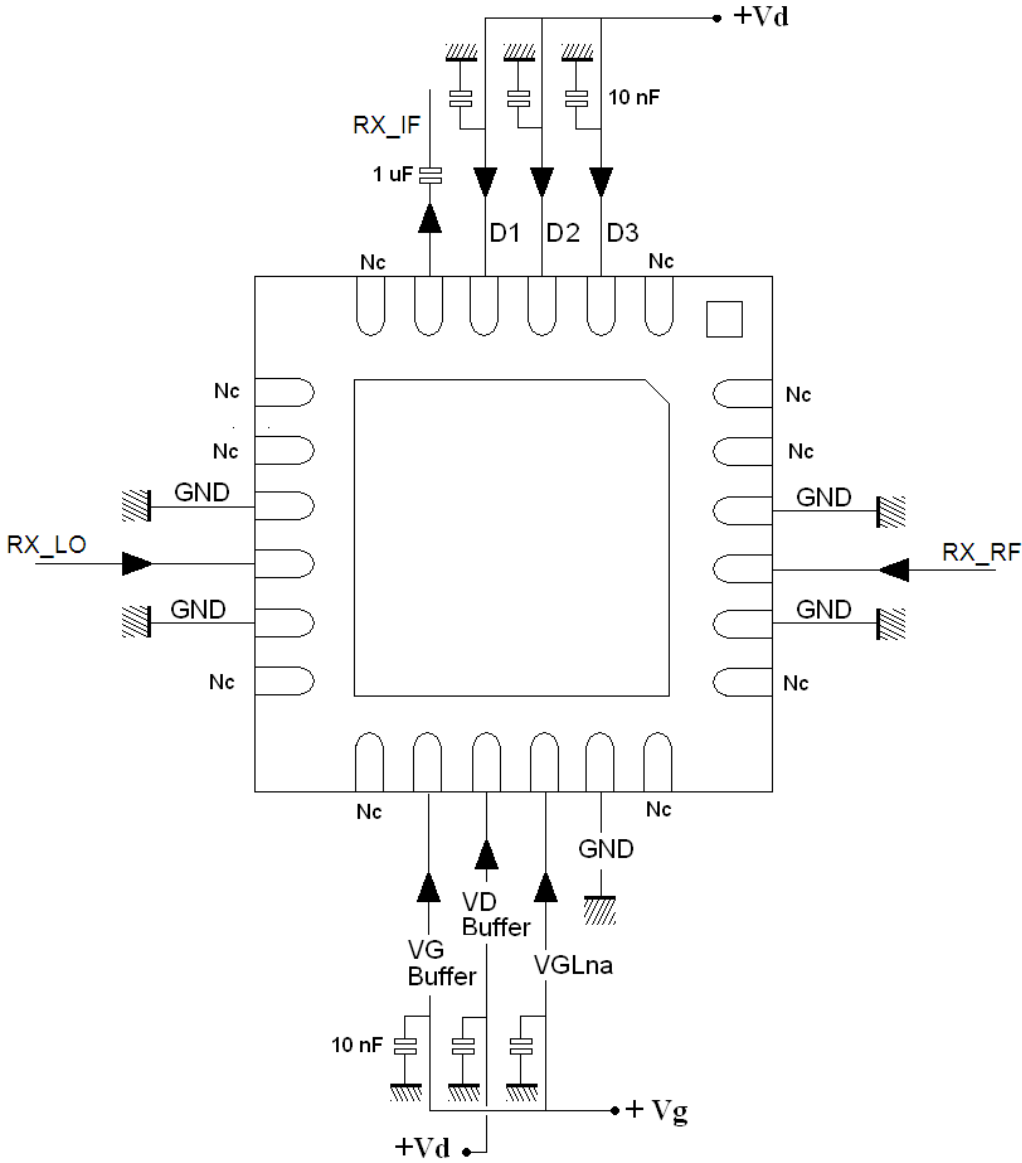

(1) The package outline drawing included to this data-sheet is given for indication. Refer to the application note AN0017 (<http://www.ums-gaas.com>) for exact package dimensions.

(2) It is strongly recommended to ground all pins marked "Gnd" through the PCB board. Ensure that the PCB board is designed to provide the best possible ground to the package.

Recommended Test Fixture (Ref. 95541) for measurements over Temperature Range

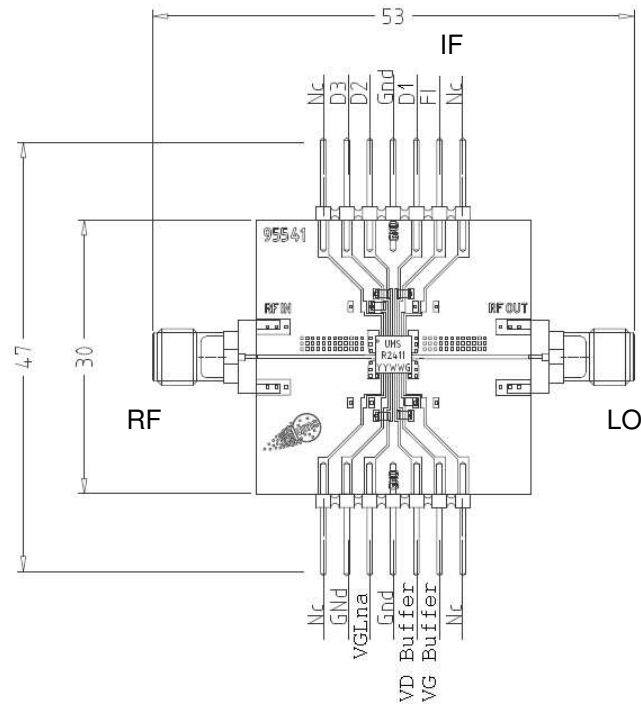

Unit = mm

1uF in series capacitor is recommended on IF port.

Recommended Test Fixture (Ref. 95581) for measurements in the package's plans with probes

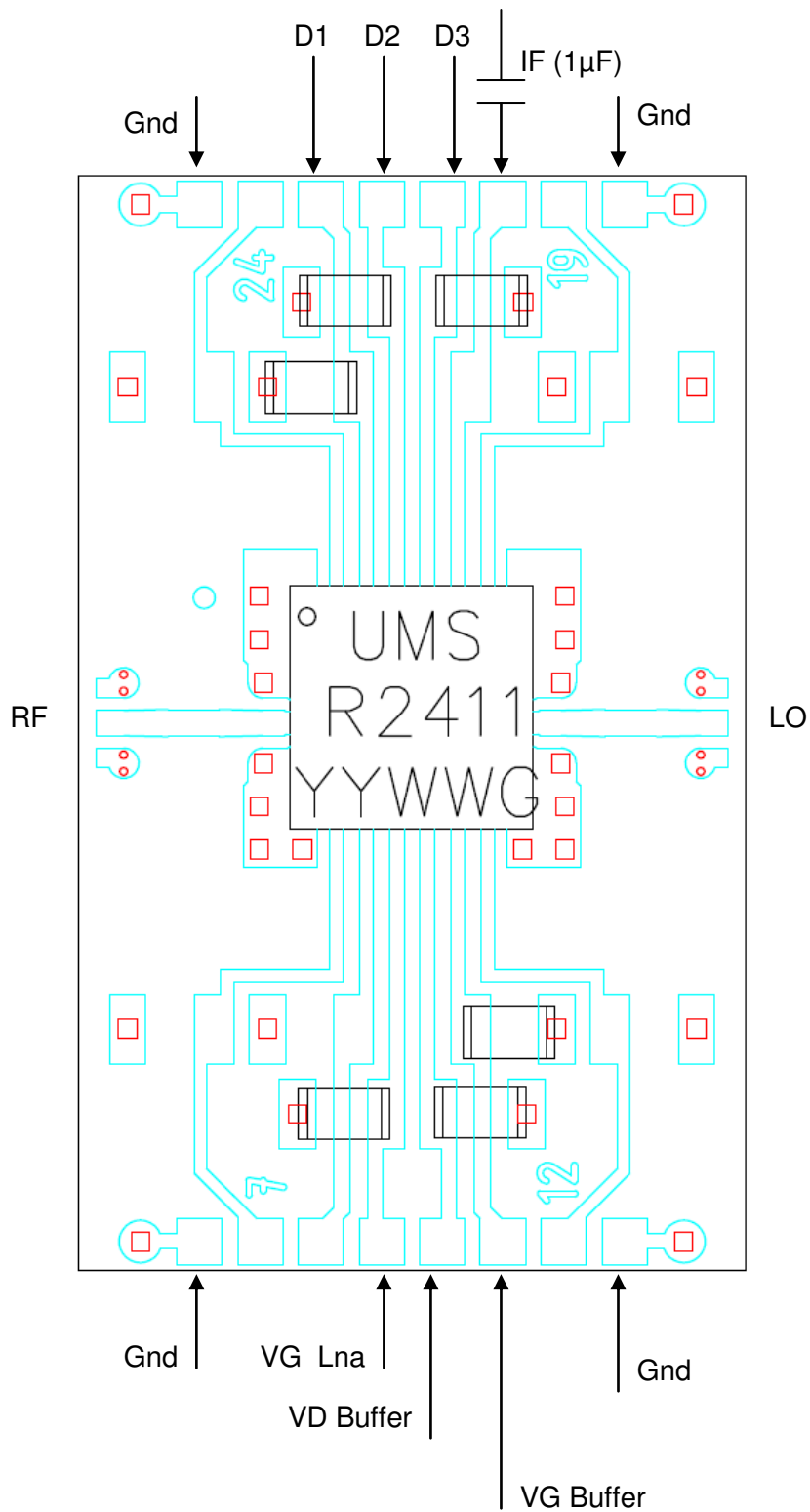

BOM: 6 capacitors 0603 of 10nF

ESD sensitivity

Standard	Value
MIL-STD-1686C	HBM Class 1 (>0V – 1999V)
ESD STM5.1-2001	HBM Class 0 (<250V)

Package Information

Parameter	Value
Package body material	RoHS-compliant
	Low stress Injection Molded Plastic
Lead finish	100% matte Sn
MSL Rating	MSL1

Recommended package footprint

Refer to the application note AN0017 available at <http://www.ums-gaas.com> for package footprint recommendations.

SMD mounting procedure

For the mounting process standard techniques involving solder paste and a suitable reflow process can be used. For further details, see application note AN0017.

Recommended environmental management

UMS products are compliant with the regulation in particular with the directives RoHS N°2011/65 and REACH N°1907/2006. More environmental data are available in the application note AN0019 also available at <http://www.ums-gaas.com>.

Recommended ESD management

Refer to the application note AN0020 available at <http://www.ums-gaas.com> for ESD sensitivity and handling recommendations for the UMS package products.

Ordering Information

QFN 4x4 package:

CHR2411-QDG/XY

Stick: XY = 20

Tape & reel: XY = 21

Information furnished is believed to be accurate and reliable. However **United Monolithic Semiconductors S.A.S.** assumes no responsibility for the consequences of use of such information nor for any infringement of patents or other rights of third parties which may result from its use. No license is granted by implication or otherwise under any patent or patent rights of **United Monolithic Semiconductors S.A.S.** Specifications mentioned in this publication are subject to change without notice. This publication supersedes and replaces all information previously supplied. **United Monolithic Semiconductors S.A.S.** products are not authorised for use as critical components in life support devices or systems without express written approval from **United Monolithic Semiconductors S.A.S.**