

## 6-9GHz Integrated Down Converter

### GaAs Monolithic Microwave IC in SMD package

### Description

The CHR3861-QEG is a multifunction part, which integrates a balanced cold FET mixer, a LO buffer, and a RF LNA including gain control. It is designed for a wide range of applications, typically ISM and commercial communication systems.

The circuit is manufactured on a pHEMT process, 0.25 $\mu$ m gate length.

It is supplied in lead-free SMD package.

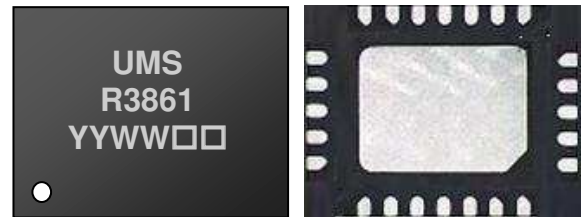

### Main Features

- RF performance 5.9-9.0GHz
- 12dB conversion gain
- 1dBm Input IP3
- 9dB Gain Control
- 15dBc Image Rejection
- 24LQFN4x5
- ESD protected

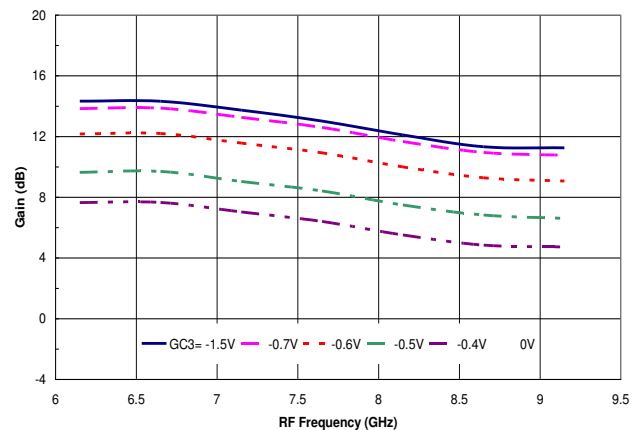

### Main Characteristics

Tamb = +25 °C, Vd = 4V

Symbol	Parameter	Min	Typ	Max	Unit
F <sub>RF</sub>	RF frequency range	5.9		9.0	GHz
F <sub>LO</sub>	LO frequency range	3.0		12.5	GHz
F <sub>IF</sub>	IF frequency range	DC		3.5	GHz
G <sub>c</sub>	Conversion gain		12		dB

ESD Protections: Electrostatic discharge sensitive device observe handling precautions!

## Electrical Characteristics

Tamb = +25°C, VD = VD1 = 4V

### Configuration 1: High linearity with GC4 fixed at 0V

Symbol	Parameter	Min	Typ	Max	Unit
FRF	RF frequency range	5.9		9.0	GHz
FLO	LO frequency range	3.0		12.5	GHz
FIF	IF frequency range	DC		3.5	GHz
Gc	Conversion gain @ min. attenuation <sup>(1)</sup>		12		dB
$\Delta G$	Gain control range with only Gc3		9		dB
NF	Noise Figure @ min. attenuation, for IF>0.1GHz		2.5		dB
Im_rej	Image rejection <sup>(1)</sup>		15		dBc
PLO	LO Input power		0		dBm
IIP3	Input IP3@ at Gc max.		1		dBm
VD, VD1	DC drain voltage		4		V
Id	Total drain current at Gc max.		380		mA
VG	LNA DC gate voltage		-0.3		V
B	LO buffer & X2 DC voltage		-4		V
GC3	Gain control DC voltage	-1.5		0	V
GC4	Gain control DC voltage	0		0	V

(1) An external combiner 90° is required on I / Q.

These values are representative of on board measurements as defined on the drawing at paragraph "Evaluation mother board".

Note: Id not affected by GC3, GC4.

**Configuration 2: High Gain & low Noise with GC3 = GC4**

Symbol	Parameter	Min	Typ	Max	Unit
FRF	RF frequency range	5.9		9.0	GHz
FLO	LO frequency range	3.0		12.5	GHz
FIF	IF frequency range	DC		3.5	GHz
Gc	Conversion gain@ min. attenuation <sup>(1)</sup>		22		dB
$\Delta G$	Gain control range with Gc3=GC4		18		dB
NF	Noise Figure@ min. attenuation		2		dB
Im_rej	Image rejection <sup>(1)</sup>		15		dBc
PLO	LO Input power		0		dBm
IIP3	Input IP3@ at Gc max.		-6		dBm
VD, VD1	DC drain voltage		4		V
Id	Total drain current at Gc max.		380		mA
VG	LNA DC gate voltage		-0.3		V
B	LO buffer & Mixer DC voltage		-4		V
GC3, GC4	Gain control DC voltage	-1.5		0	V

(1) An external combiner 90° is required on I / Q.  
 These values are representative of on board measurements as defined on the drawing at paragraph "Evaluation mother board".

Note: Id not affected by GC3, GC4.

Note: Electrostatic discharge sensitive device observe handling precautions!

## Absolute Maximum Ratings <sup>(1)</sup>

Tamb = +25°C

Symbol	Parameter	Values	Unit
VD, VD1	Maximum drain bias voltage	4.5	V
Id	Maximum drain bias current	450	mA
VG	LNA DC gate voltage	-2.0 to 0.4	V
B	Buffer & Mixer DC voltage	-5	V
GCx	Gain control voltage	-2 to 1	V
P_RF	Maximum peak input power overdrive	10	dBm
P_LO	Maximum LO input power	5	dBm
Tch	Maximum channel temperature <sup>(1)</sup>	175	°C
Ta	Operating temperature range	-40 to +85	°C
Tstg	Storage temperature range	-55 to +125	°C

(1) Operation of this device above anyone of these paramaters may cause permanent damage.

## Device thermal performances

All the figures given in this section are obtained assuming that the QFN device is cooled down only by conduction through the package thermal pad (convection mode not considered).

The temperature is monitored at the package back-side interface ( $T_{case}$ ) as shown below. The system maximum temperature must be adjusted in order to guarantee that  $T_{case}$  remains below than the maximum value specified in the next table. So, the system PCB must be designed to comply with this requirement.

A derating must be applied on the dissipated power if the  $T_{case}$  temperature can not be maintained below than the maximum temperature specified in order to guarantee the nominal device life time (MTTF) (see the curve  $P_{diss. Max}$  below).

DEVICE THERMAL SPECIFICATION : CHR3861-QEG	
Recommended max. junction temperature ( $T_J$ max)	: 164 °C
Junction temperature absolute maximum rating	: 175 °C
Max. continuous dissipated power ( $P_{diss. Max.}$ )	: 1.5 W
=> $P_{diss. Max.}$ derating above $T_{case}^{(1)} = 85$ °C	: 19 mW/°C
Junction-Case thermal resistance ( $R_{th J-C}^{(2)}$ )	: <51 °C/W
Minimum $T_{case}$ operating temperature <sup>(3)</sup>	: -40 °C
Maximum $T_{case}$ operating temperature <sup>(3)</sup>	: 85 °C
Minimum storage temperature	: -55 °C
Maximum storage temperature	: 150 °C

(1) Derating at junction temperature constant =  $T_J$  max.

(2)  $R_{th J-C}$  is calculated for a worst case considering the **hottest junction** of the MMIC and all the devices biased.

(3)  $T_{case}$  = Package back side temperature measured under the die-attach-pad (see the drawing below).

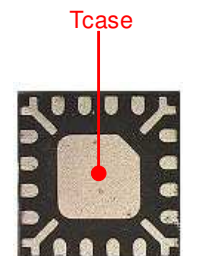
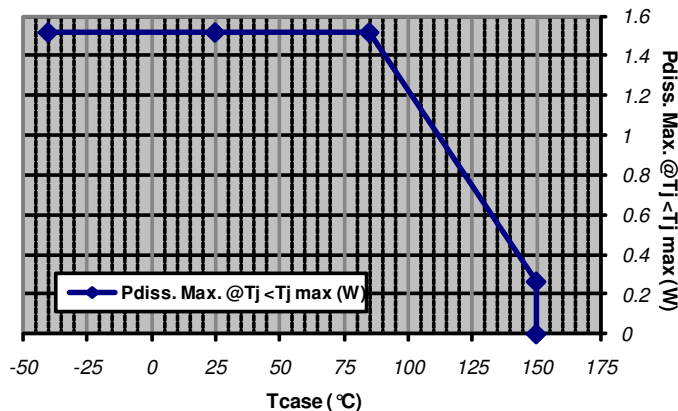

Example: QFN 16L 3x3  
Location of temperature reference point ( $T_{case}$ ) on package's bottom side

6.1

## Typical Measured Performances

Tamb = +25°C, VD = VD1 = 4V, VG = -0.3V, B = -4V, P\_LO = 0dBm

If no specific mention, the following values are representative of onboard measurements (on connector access planes) as defined on the drawing at paragraph "Evaluation mother board". The board losses are estimated from 0.5 to 0.7dB in the frequency range.

### Configuration 1: High linearity

Gain versus GC3 with GC4 = 0V

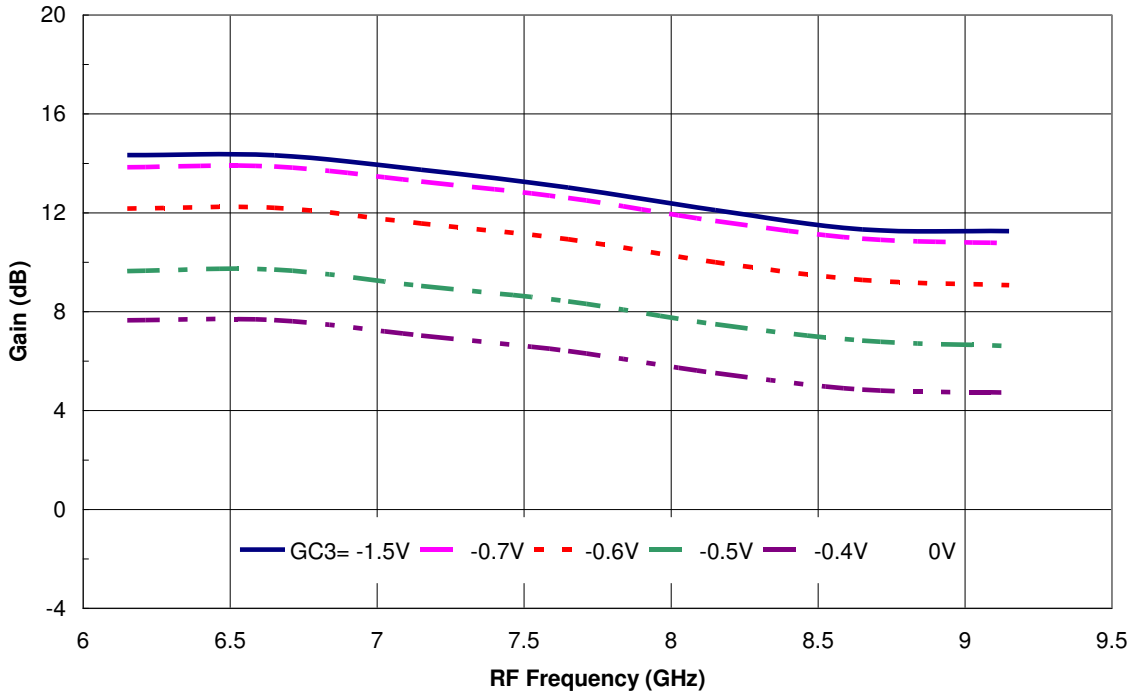

Input IP3 versus GC3 at RF = 6.2GHz & GC4 = 0V

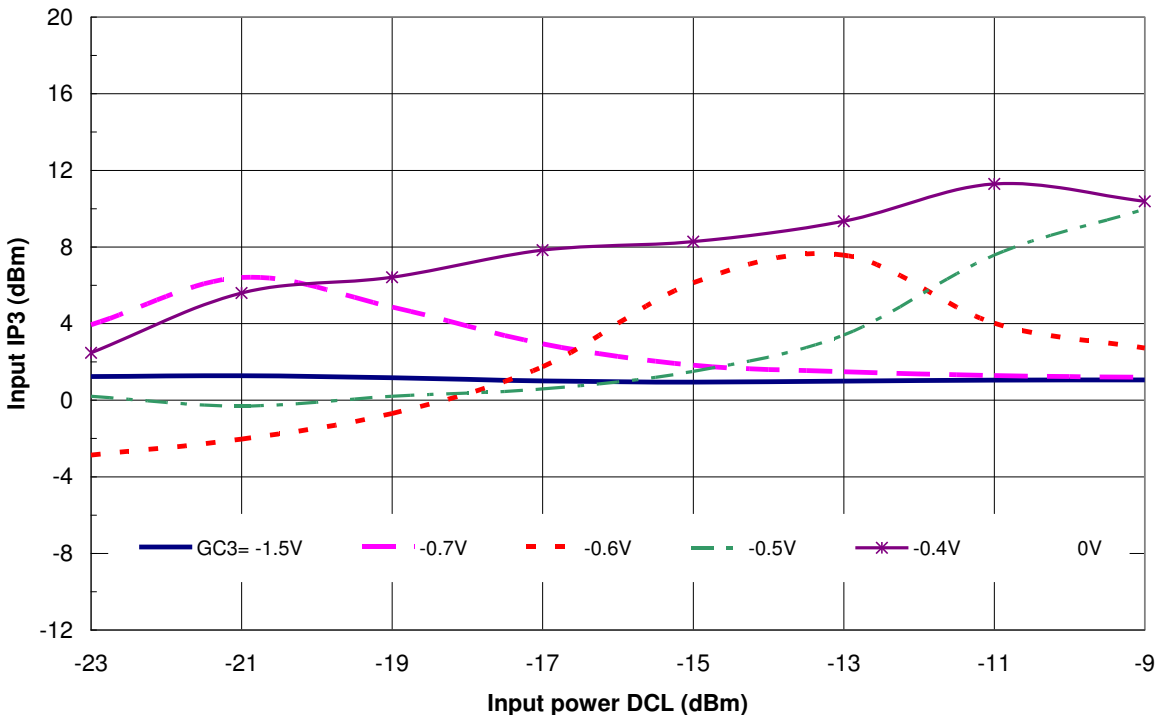

Input IP3 versus RF frequency at GC3 = -1.5V & GC4 = 0V

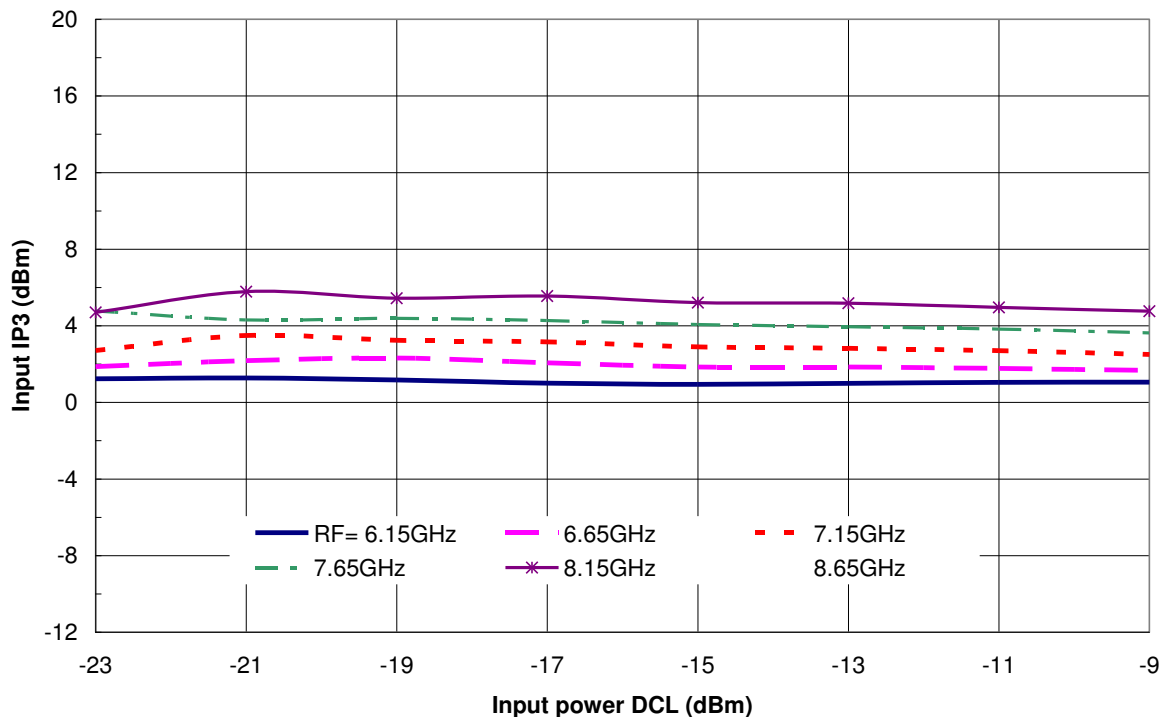

Noise figure versus temperature with GC3 = -1.5V, GC4 = 0V & IF = 1.4GHz

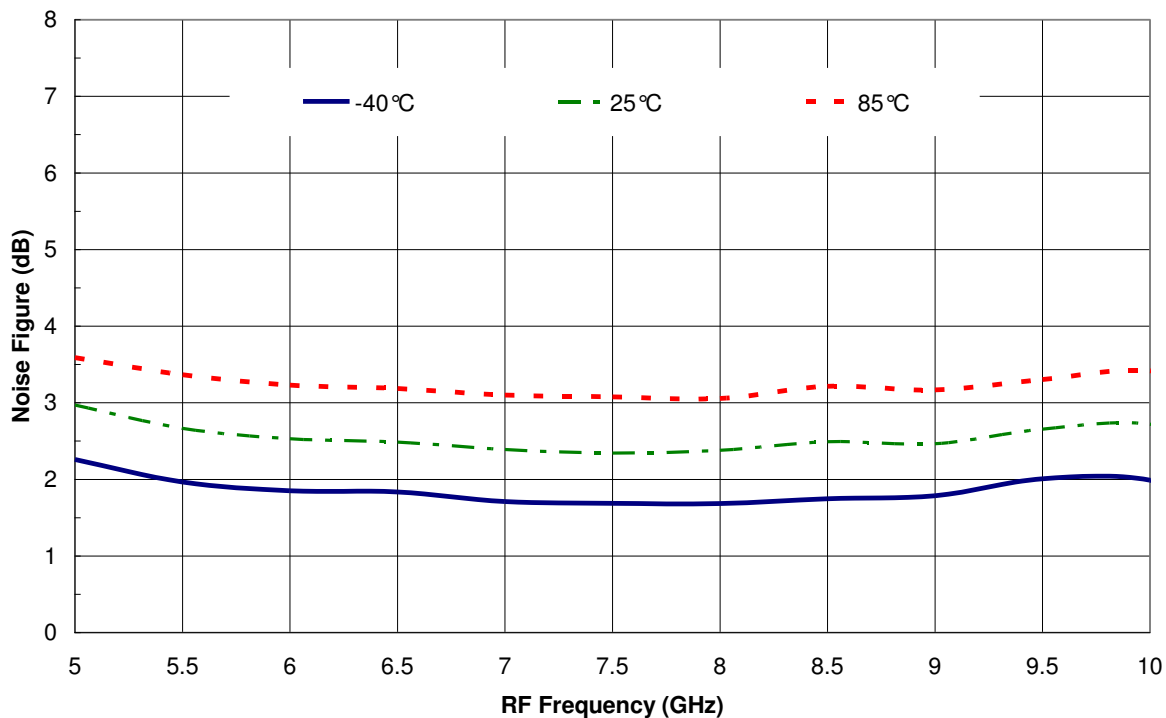

Noise figure versus GC3 with GC4 = 0V at 25°C & IF = 1.4GHz

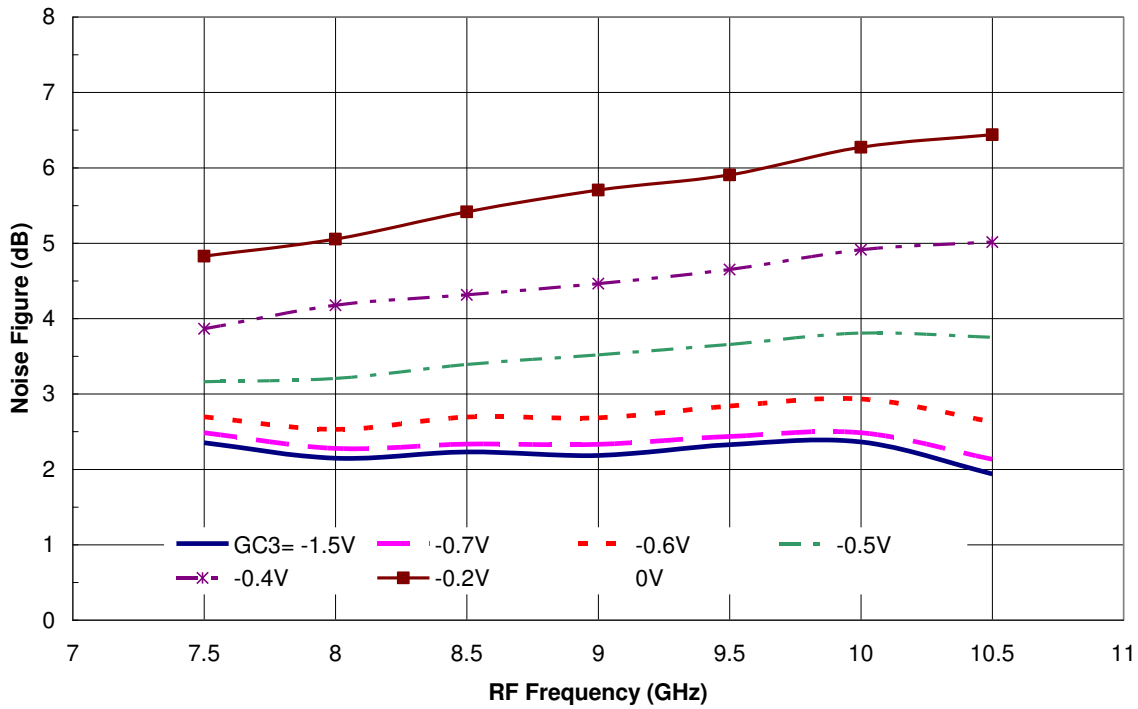

## Configuration 2: High Gain & High dynamic

Gain versus GC3 = GC4

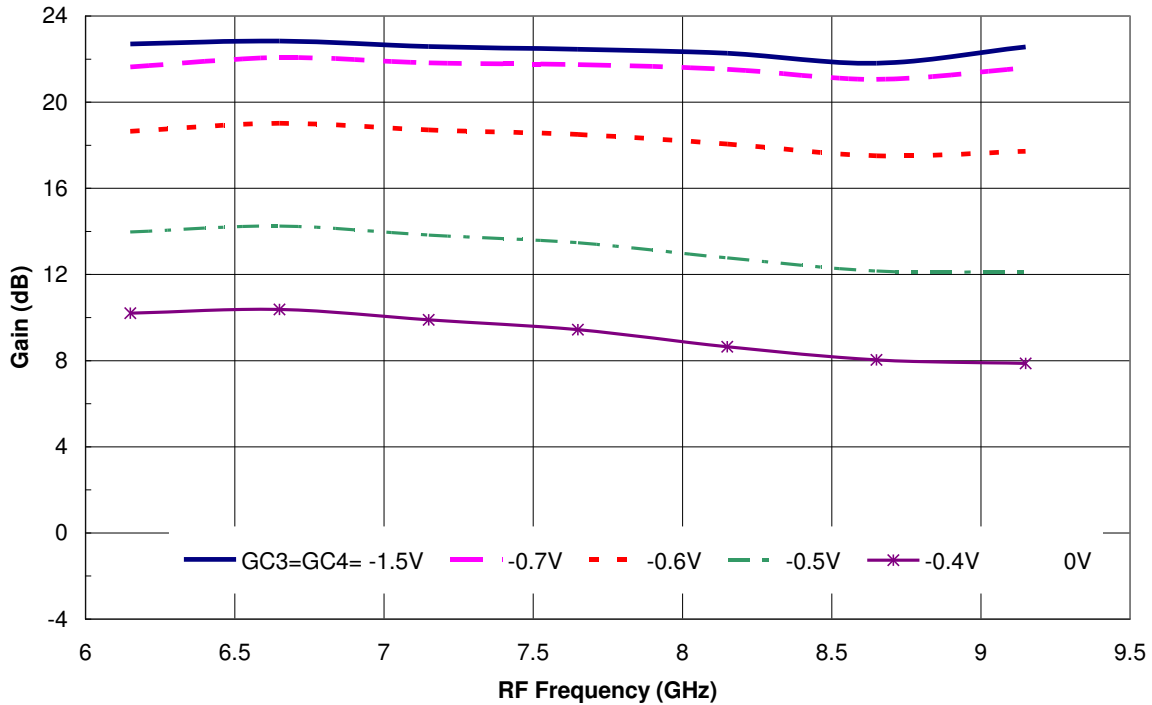

Input IP3 at RF=6.2GHz with GC3 = GC4

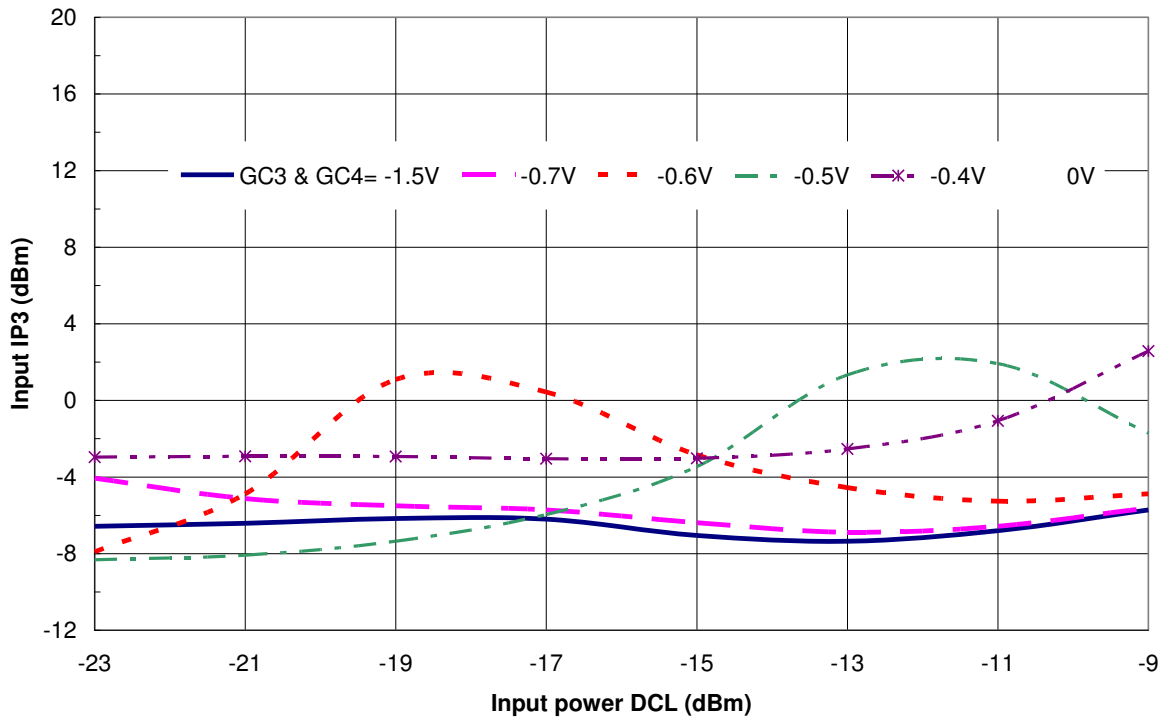

Noise figure versus temperature with GC3 = GC4 at max. Gain & IF = 1.4GHz

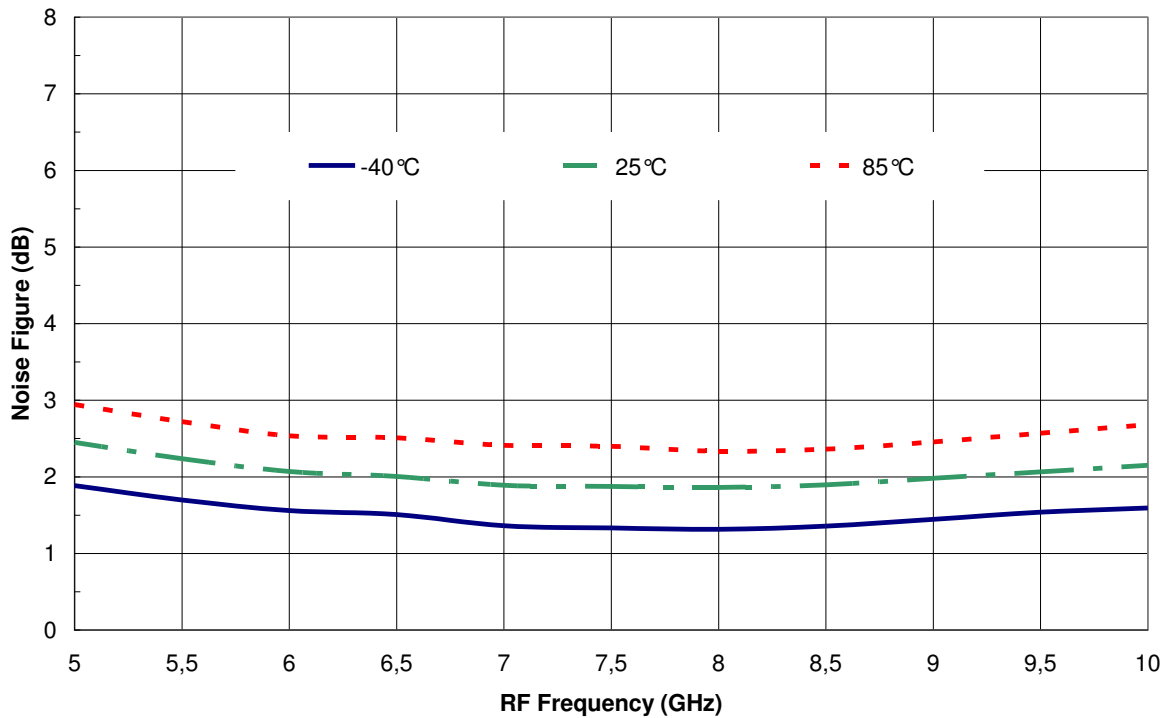
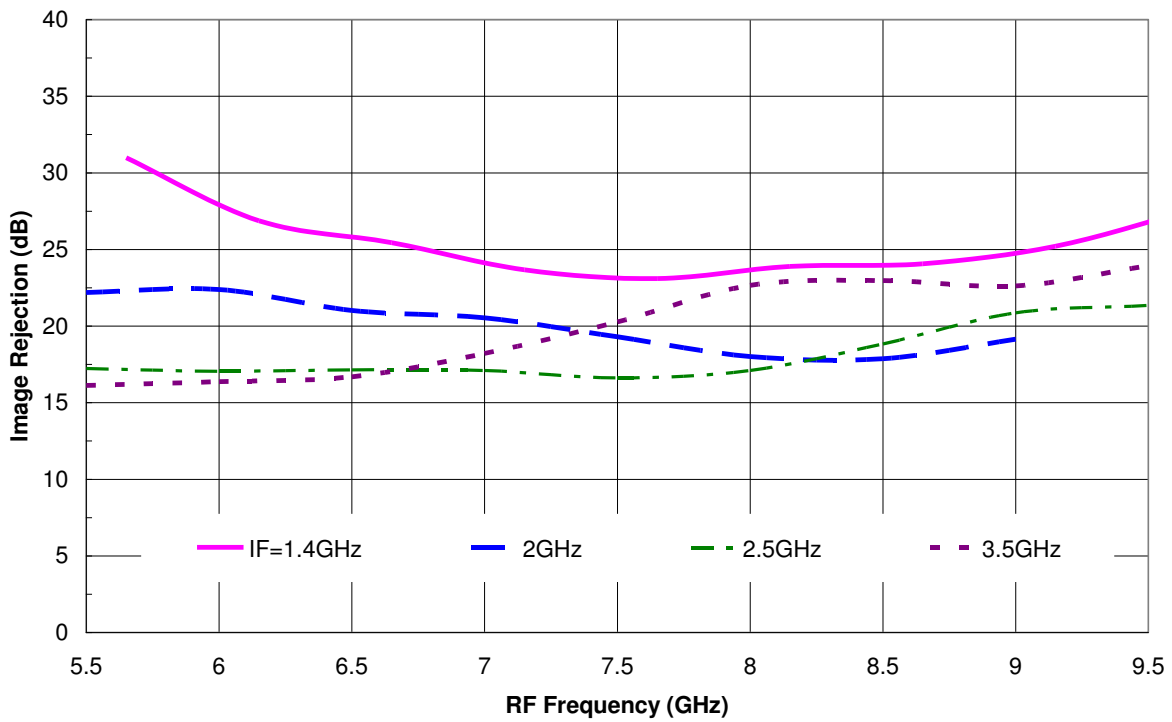
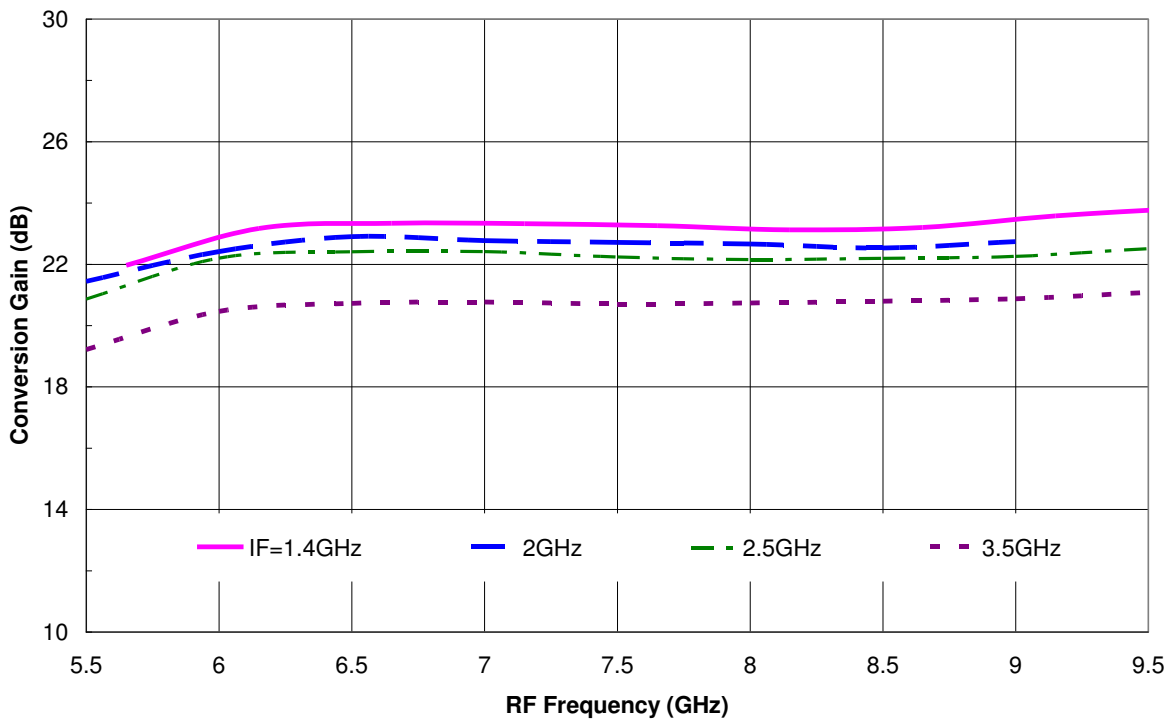

Image rejection versus IF with GC3 = GC4 at max. Gain



Conversion Gain versus IF with GC3 = GC4 at max. Gain  
 $RF = LO - IF$



Conversion Gain versus IF with GC3 = GC4 at max. Gain  
 $RF = LO + IF$

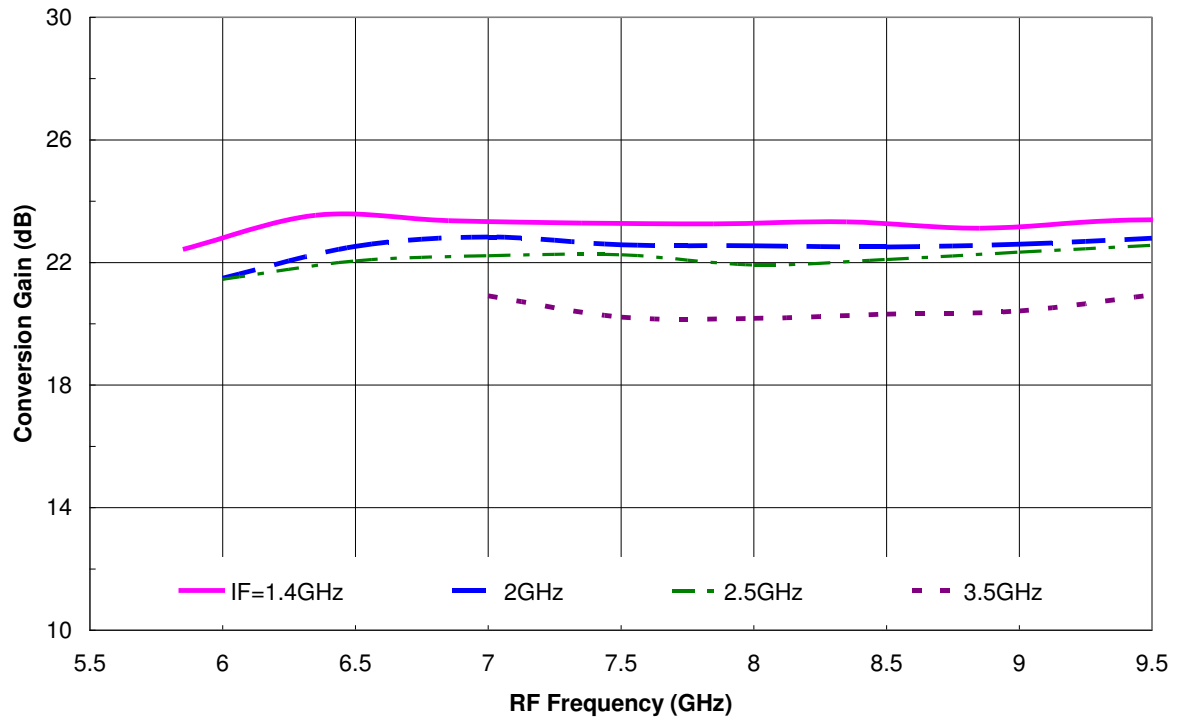

Conversion Gain versus temperature at max. Gain  
 $RF = LO - IF$

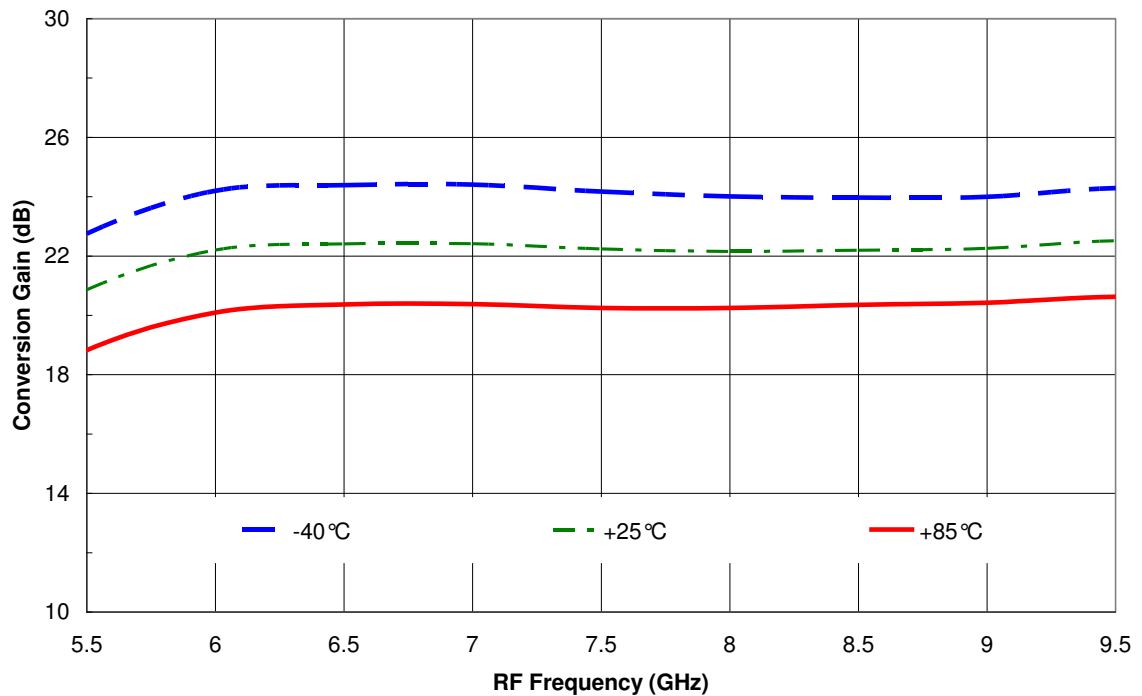

2<sup>nd</sup> order intermodulation

$$RF = LO + IF$$

$$F_{RF} = 7.5 \text{ GHz}$$

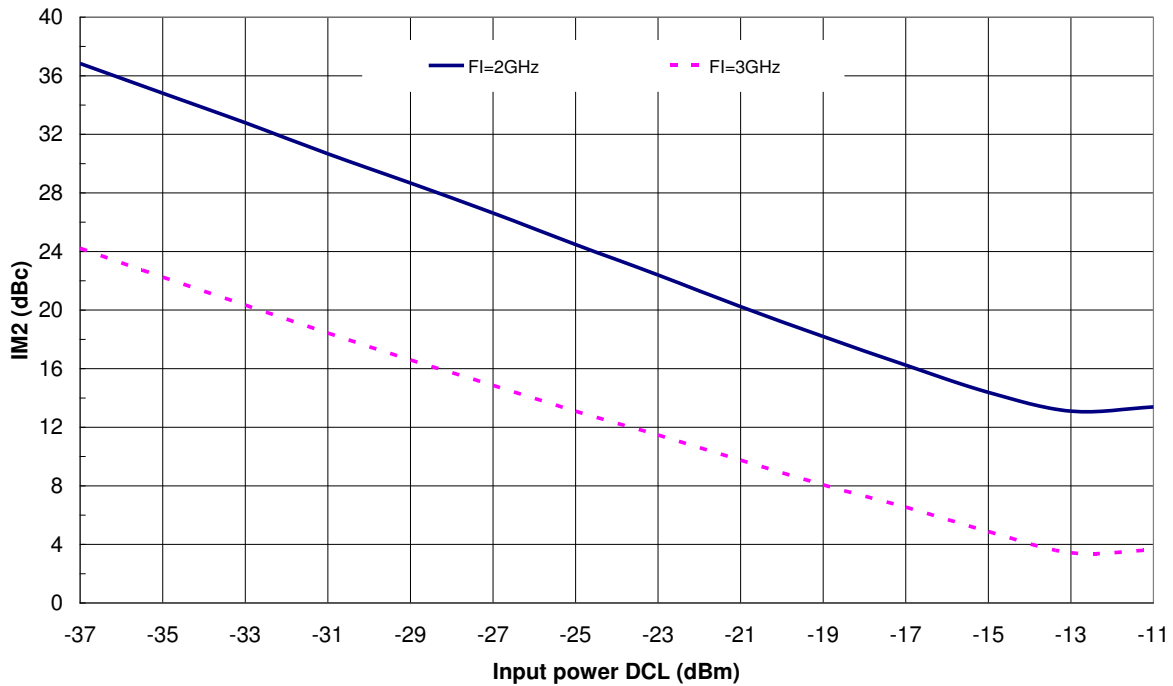

Spurious on IF outputs

$$RF = LO + IF$$

$$P_{RF} = -30\text{dBm @7GHz} / P_{LO} = 0\text{dBm @6GHz}$$

	nLO				
mRF	0	1	2	3	4
0	xx	6	26	33	30
1	10	0	24	40	48
2	60	56	28	38	75
3	66	80	70	58	58
4	68	56	80	75	38

All values in dBc below IF power level (IF = 1GHz).  
Data measured without external hybrid coupler.

Package outline <sup>(1)</sup>

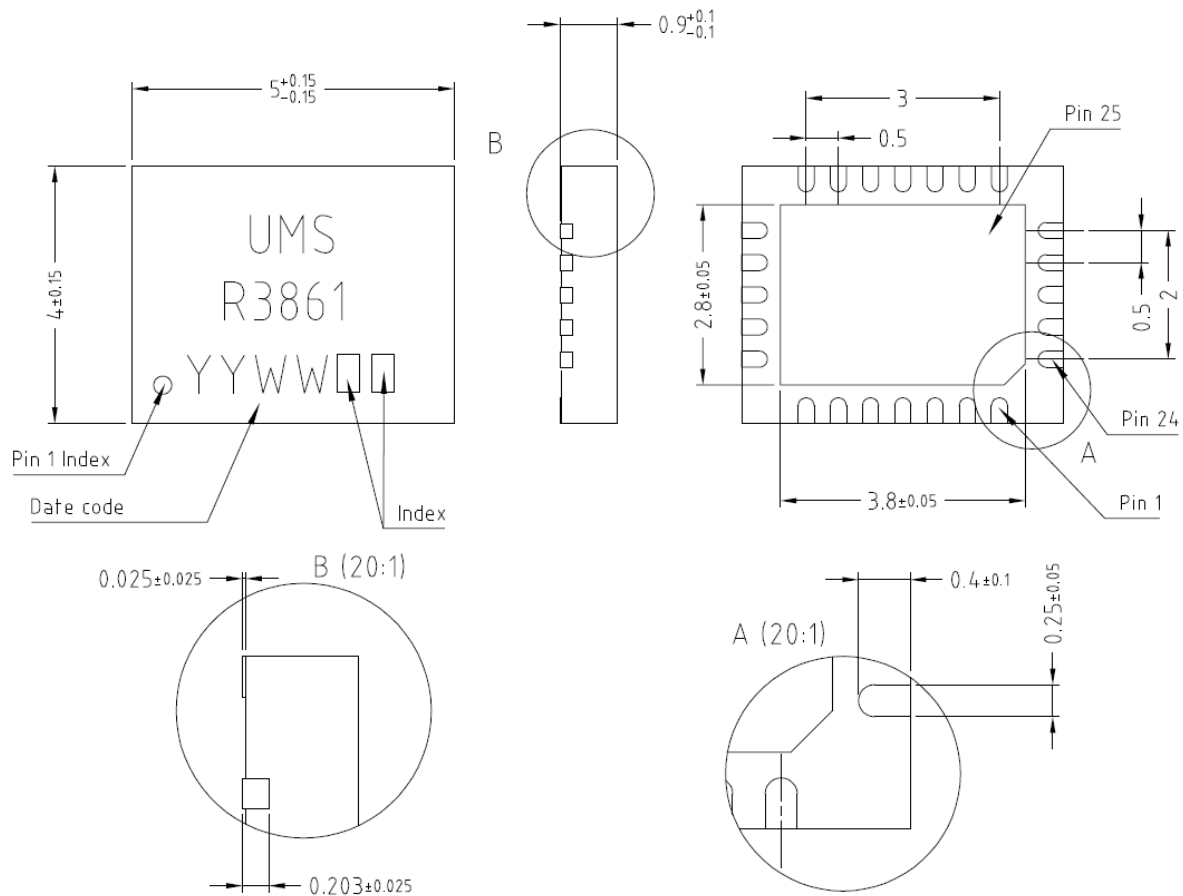

Units : mm

From the standard : JEDEC MO-220 [ VGHD]

Matt tin, Lead free (Green)

1- Nc	9- VG	17- Nc	25- GND Exposed pad
2- Nc	10- VD1	18- Nc	
3- Nc	11- VD	19- Nc	
4- GND <sup>(2)</sup>	12- B	20- IF_I out	
5- RF in	13- Nc	21- GND <sup>(2)</sup>	
6- Nc	14- Nc	22- IF_Q out	
7- GC4	15- LO in	23- Nc	
8- GC3	16- GND <sup>(2)</sup>	24- Nc	

<sup>(1)</sup> The package outline drawing included to this data-sheet is given for indication. Refer to the application note AN0017 available at <http://www.ums-gaas.com> for exact package dimensions.

<sup>(2)</sup> It is strongly recommended to ground on the PCB board all the pins referenced as GND.

**Evaluation mother board**

- Compatible with the proposed footprint.
- Based on typically Ro4003 / 8mils or equivalent.
- Using a microstrip to coplanar transition to access the package.
- Recommended for the implementation of this product on a module board.
- Decoupling capacitors of 10nF  $\pm 10\%$  are recommended for all DC accesses.
- (See application note AN0017 for details).

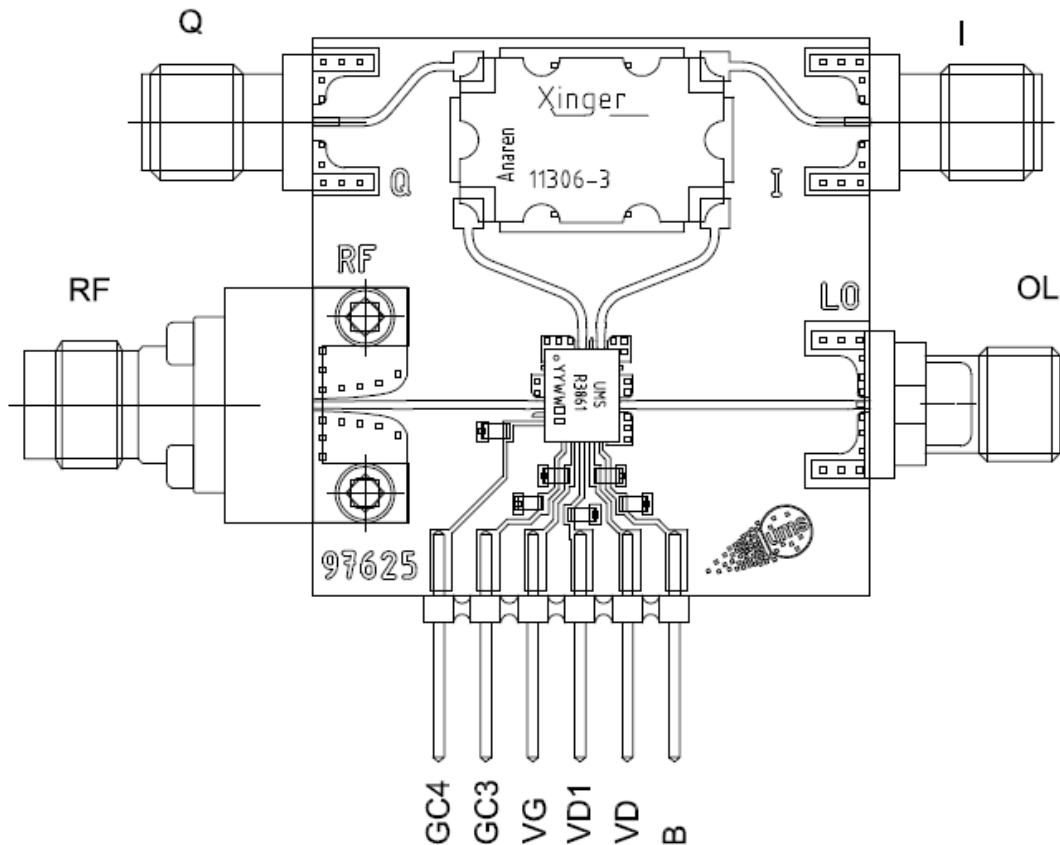

Decoupling Capacitors = 10nF  
 Hybrid coupler Anaren 90° 2-4GHz

## Notes

Due to ESD protection circuits on RF and LO inputs, an external capacitance might be requested to isolate the product from external voltage that could be present on these accesses in the application.

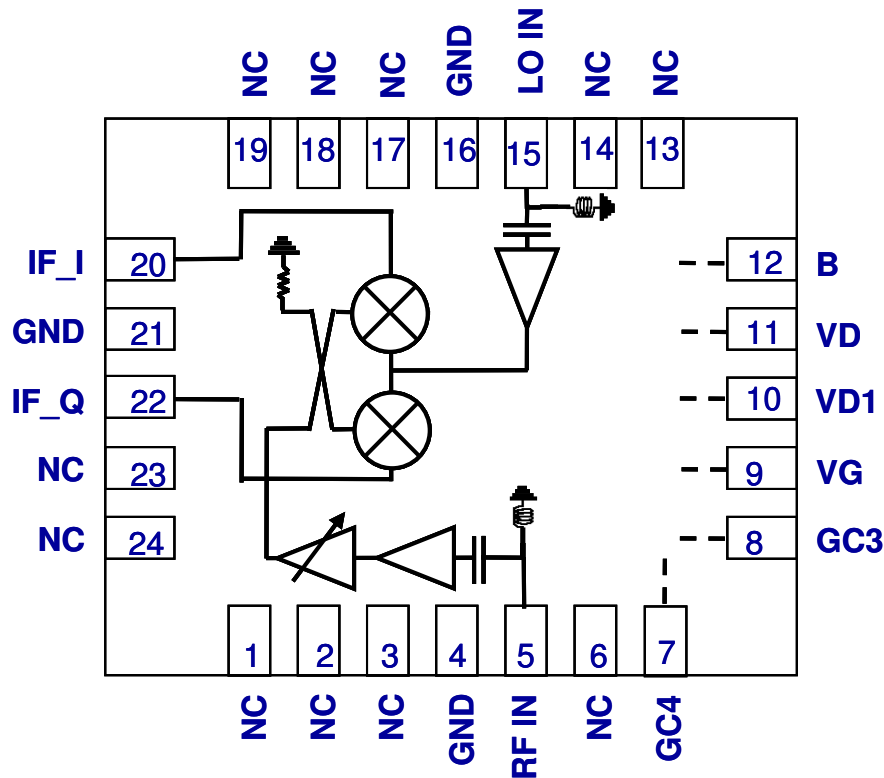

ESD protections are also implemented on gate accesses.

The DC connections do not include any decoupling capacitor in package, therefore it is mandatory to provide a good external DC decoupling on the PC board, as close as possible to the package.

## DC Schematic

LNA: 4V, 240mA

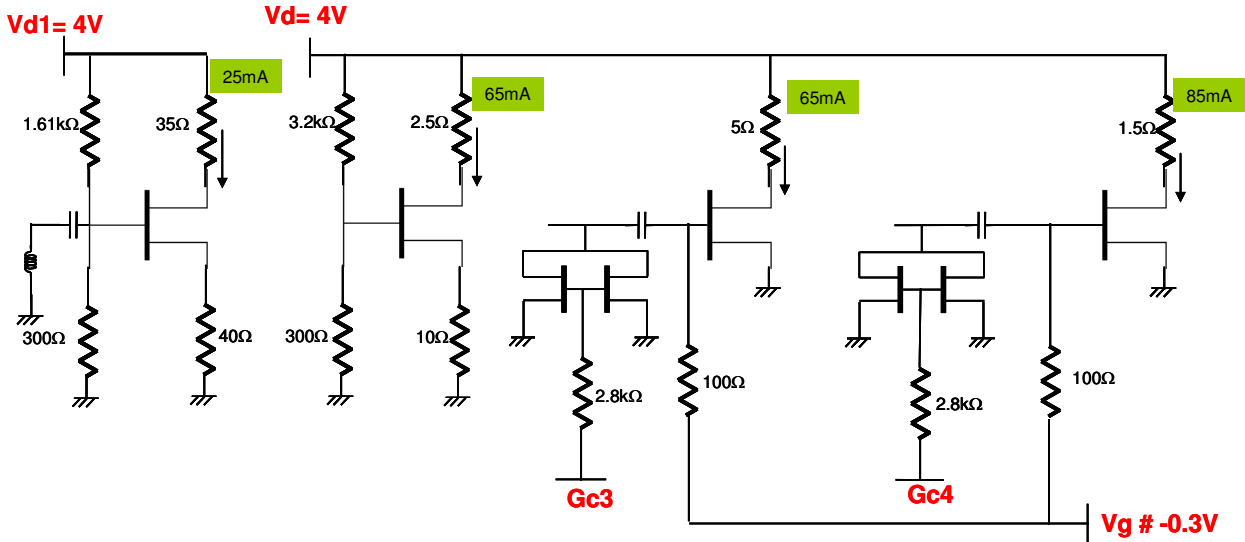

LO Buffer: 4V, 140mA

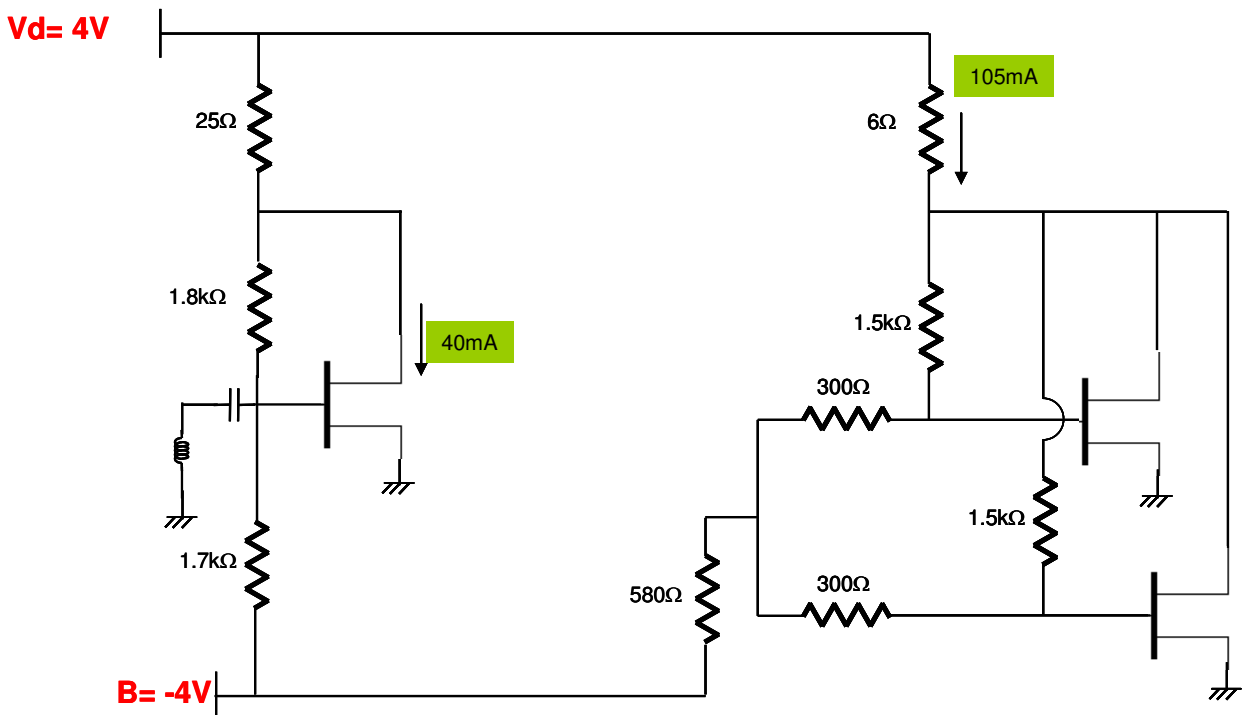

**Notes**

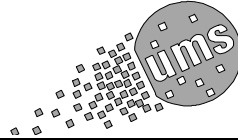

### **Recommended package footprint**

Refer to the application note AN0017 available at <http://www.ums-gaas.com> for package footprint recommendations and exact package dimensions.

### **SMD mounting procedure**

For the mounting process standard techniques involving solder paste and a suitable reflow process can be used. For further details, see application note AN0017.

### **Recommended environmental management**

Refer to the application note AN0019 available at <http://www.ums-gaas.com> for environmental data on UMS package products.

### **Recommended ESD management**

Refer to the application note AN0020 available at <http://www.ums-gaas.com> for ESD sensitivity and handling recommendations for the UMS package products.

## **Ordering Information**

QFN 4x5 RoHS compliant package:      CHR3861-QEG/XY  
Stick: XY = 20              Tape & reel: XY = 21

Information furnished is believed to be accurate and reliable. However **United Monolithic Semiconductors S.A.S.** assumes no responsibility for the consequences of use of such information nor for any infringement of patents or other rights of third parties which may result from its use. No license is granted by implication or otherwise under any patent or patent rights of **United Monolithic Semiconductors S.A.S.**. Specifications mentioned in this publication are subject to change without notice. This publication supersedes and replaces all information previously supplied. **United Monolithic Semiconductors S.A.S.** products are not authorised for use as critical components in life support devices or systems without express written approval from **United Monolithic Semiconductors S.A.S.**