

## 5.5-9GHz Integrated Down Converter

### GaAs Monolithic Microwave IC in SMD leadless package

#### Description

The CHR3762-QDG is a multifunction monolithic receiver, which integrates a balanced cold FET mixer, a LO buffer, and a RF low noise amplifier.

It is designed for a wide range of applications, from military to commercial communication systems.

The circuit is manufactured with a pHEMT process, 0.25µm gate length, via holes through the substrate, air bridges and electron beam gate lithography.

It is supplied in RoHS compliant SMD package.

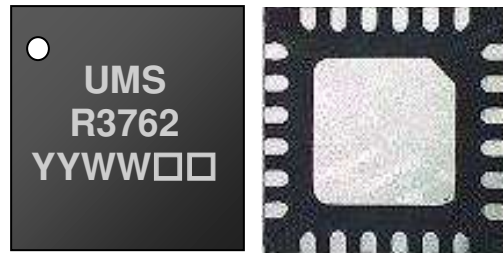

#### Main Features

- Broadband RF performances: 5.5-9GHz
- 14dB Conversion Gain
- 1.7dB Noise Figure
- 3dBm Input IP3
- DC bias: Vd=3.0V @Id=100mA
- 24L-QFN4x4
- MSL1

Conversion Gain & Noise Figure versus RF frequency @ IF = 1GHz (LSB mode)

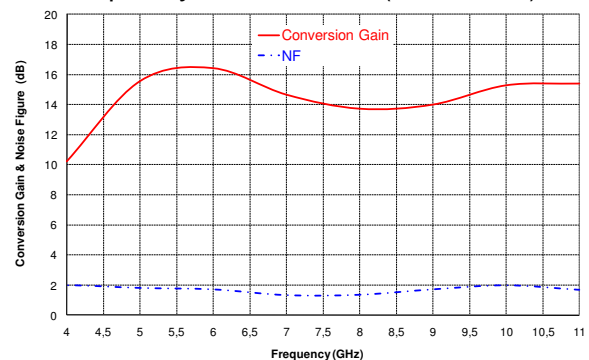

#### Main Electrical Characteristics

Tamb.= +25°C

Symbol	Parameter	Min	Typ	Max	Unit
F <sub>RF</sub>	RF Frequency	5.5		9.0	GHz
F <sub>IF</sub>	IF frequency	DC		3.5	GHz
G	Conversion gain		14		dB
NF	Noise Figure		1.7		dB

### Electrical Characteristics

Tamb.= +25°C, VD1= VD2= VD3 = +3.0V <sup>(1)</sup>

Symbol	Parameter	Min	Typ	Max	Unit
F <sub>RF</sub>	RF Frequency range	5.5		9.0	GHz
F <sub>LO</sub>	LO frequency range	4.0		12.0	GHz
F <sub>IF</sub>	IF frequency range	DC		3.5	GHz
G	Conversion gain <sup>(2)</sup>		14		dB
NF	Noise Figure		1.7		dB
Im_rej	Image rejection <sup>(2)</sup>	15			dBc
P <sub>LO</sub>	LO Input power		5		dBm
IIP3	Input IP3		3		dBm
LO RL	LO return loss		12		dB
RF RL	RF return loss		9		dB
VDx	DC drain voltage		3		V
VG1	1 <sup>st</sup> stage LNA DC gate voltage		-0.45		V
VG2	2 <sup>nd</sup> stage LNA DC gate voltage		-0.35		V
VG3	LO buffer DC gate voltage		-0.45		V
VG4	Mixer DC gate voltage		-1		V
Id	Total drain current (ID1+ID2+ID3) <sup>(3)</sup>		100		mA

These values are representative of onboard measurements as defined on the drawing in paragraph "Evaluation mother board".

<sup>(1)</sup> VD1: 1<sup>st</sup> stage LNA drain bias voltage. VD2: 2<sup>nd</sup> stage LNA drain bias voltage.

<sup>(1)</sup> VD3: LO-chain drain bias voltage.

<sup>(2)</sup> An external combiner 90° is required on I / Q.

<sup>(3)</sup> ID1: 1<sup>st</sup> stage LNA drain current, typically 17mA, should be tuned with VG1.

<sup>(3)</sup> ID2: 2<sup>nd</sup> stage LNA drain current, typically 45mA, should be tuned with VG2.

<sup>(3)</sup> ID3: LO-chain drain current, typically 38mA, should be tuned with VG3.

Electrostatic discharge sensitive device observe handling precautions!

**Absolute Maximum Ratings** <sup>(1)</sup>T<sub>amb.</sub> = +25 °C

Symbol	Parameter	Values	Unit
VD	Drain bias voltage	3.5	V
Id	Drain bias current	150	mA
VG1, VG2	1 <sup>st</sup> stage LNA gate bias voltages	-2 to +0.4	V
VG3	LO buffer gate bias voltage	-2 to +0.4	V
VG4	Mixer gate bias voltage	-2 to +0.4	V
P_RF	Maximum peak input power overdrive <sup>(2)</sup>	+15	dBm
P_LO	Maximum LO input power	+10	dBm
T <sub>j</sub>	Junction temperature	175	°C
T <sub>a</sub>	Operating temperature range	-40 to +85	°C
T <sub>stg</sub>	Storage temperature range	-55 to +150	°C

<sup>(1)</sup> Operation of this device above anyone of these parameters may cause permanent damage.

<sup>(2)</sup> Duration < 1s.

**Typical Bias Conditions**T<sub>amb.</sub> = +25 °C

Symbol	Pad N°	Parameter	Values	Unit
VDx	13,15,18	DC drain voltages	3	V
Id	13,15,18	Total drain current	100	mA
VG1	12	1 <sup>st</sup> stage LNA DC gate voltage	-0.45	V
VG2	14	2 <sup>nd</sup> stage LNA DC gate voltage	-0.35	V
VG3	17	LO buffer DC gate voltage	-0.45	V
VG4	19	Mixer DC gate voltage	-1	V

## Device thermal performances

All the figures given in this section are obtained assuming that the QFN device is cooled down only by conduction through the package thermal pad (no convection mode considered). The temperature is monitored at the package back-side interface (Tcase) as shown below. The system maximum temperature must be adjusted in order to guarantee that Tcase remains below the maximum value specified in the next table. So, the PCB system must be designed to comply with this requirement.

A derating must be applied on the dissipated power if the Tcase temperature can not be maintained below the maximum temperature specified (see the curve Pdiss. Max) in order to guarantee the nominal device life time (MTTF).

DEVICE THERMAL SPECIFICATION : CHR3762-QDG	
Recommended max. junction temperature (Tj max)	: 131 °C
Junction temperature absolute maximum rating	: 175 °C
Max. continuous dissipated power (Pdiss. Max.)	: 0,3 W
=> Pdiss. Max. derating above Tcase <sup>(1)</sup> = 85 °C	: 5 mW/°C
Junction-Case thermal resistance (Rth J-C) <sup>(2)</sup>	: <183 °C/W
Minimum Tcase operating temperature <sup>(3)</sup>	: -40 °C
Maximum Tcase operating temperature <sup>(3)</sup>	: 85 °C
Minimum storage temperature	: -55 °C
Maximum storage temperature	: 150 °C

(1) Derating at junction temperature constant = Tj max.

(2) Rth J-C is calculated for a worst case considering the **hottest junction** of the MMIC and all the devices biased.

(3) Tcase=P package back side temperature measured under the die-attach-pad (see the drawing below).

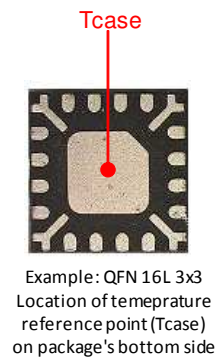
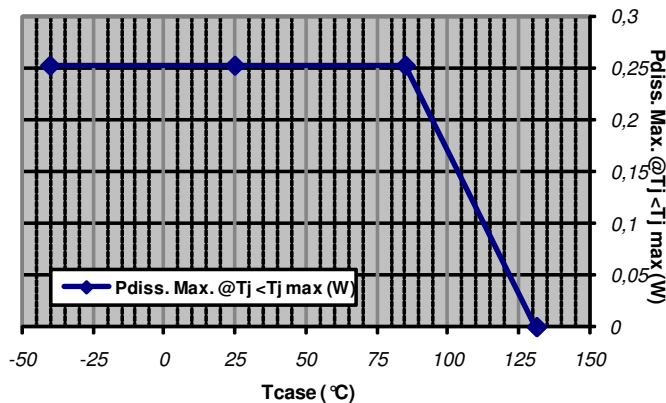

6.1

## Typical Board Measurements

Tamb.= +25 °C, VD1= VD2= VD3= +3V, VG1= -0.45V, VG2= -0.35V, VG3= -0.45V, VG4= -1V, P\_LO = +5dBm

These values are representative of onboard measurements as defined on the drawing in paragraph "Evaluation mother board". Data are given in the package access planes.

**Conversion Gain versus RF & LO power at IF = 1GHz**  
(USB mode)

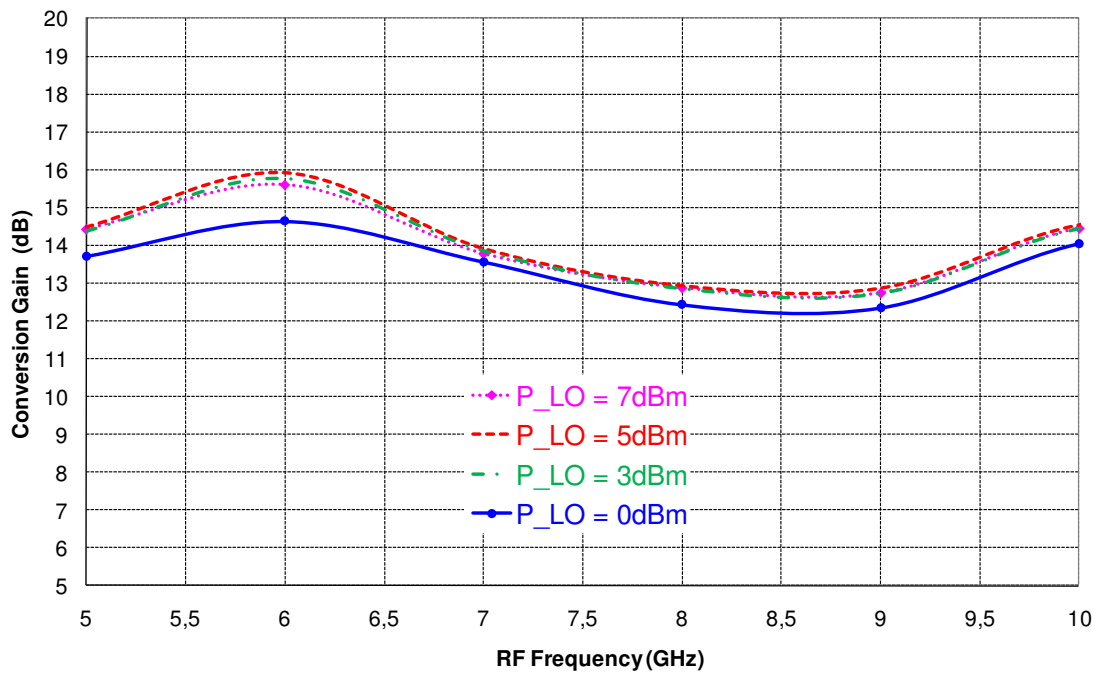

**Conversion Gain versus IF frequency at LO = 8GHz**  
(USB & LSB modes)

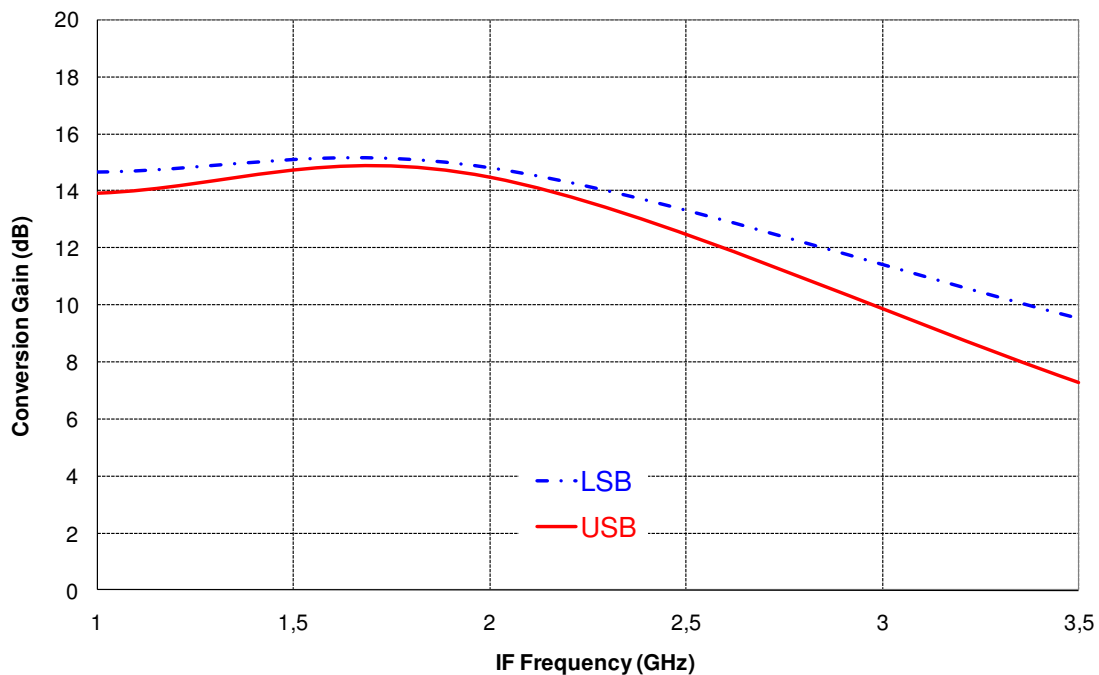

## Typical Board Measurements

Tamb.= +25°C, P\_LO = +5dBm

VD1=VD2=VD3=+3V and VG1=-0.45V, VG2=-0.35V, VG3=-0.45V, VG4=-1V

**Noise Figure versus RF frequency at IF = 1GHz**  
(USB & LSB modes)

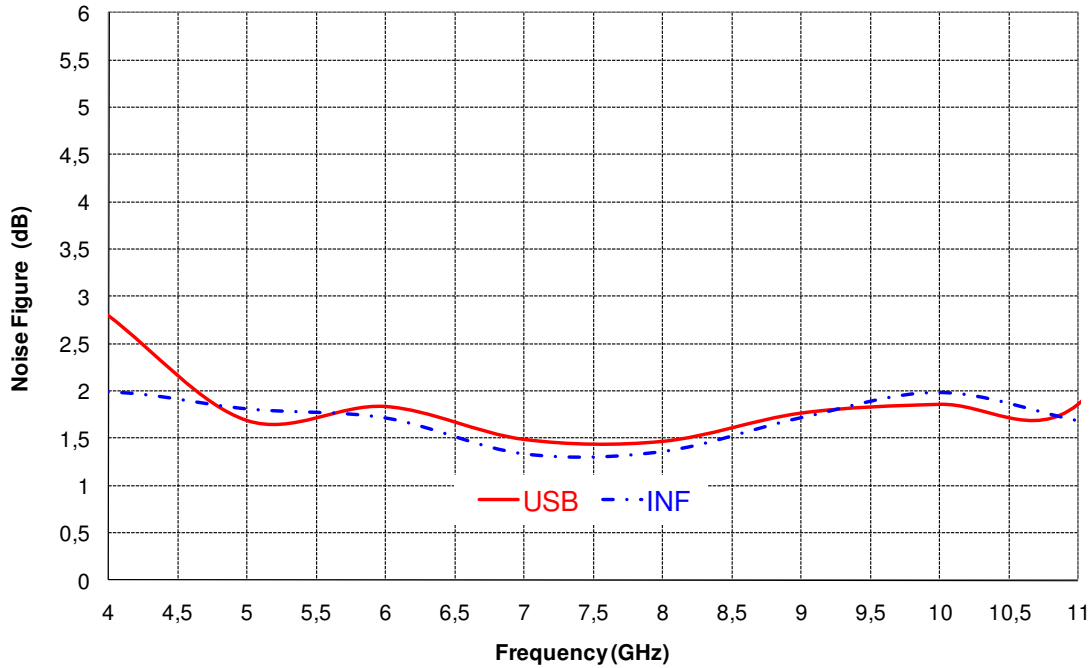

**Input IP3 versus LO power at RF = 7.5GHz & IF = 2GHz**  
(USB mode)

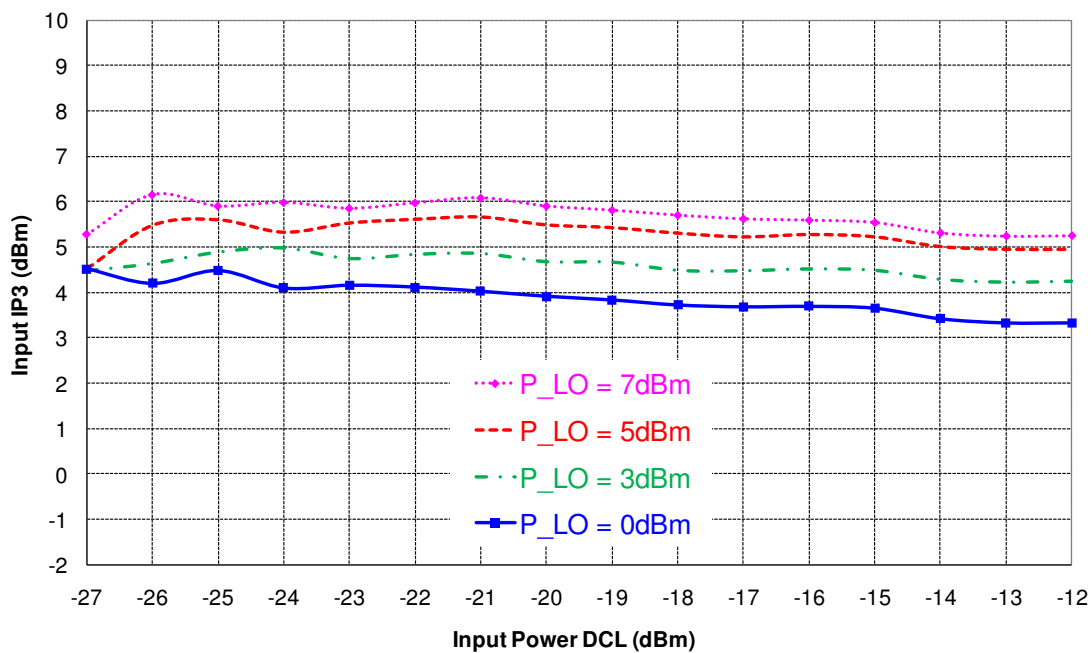

**Typical Board Measurements**

Tamb.= +25°C, P\_LO = +5dBm

VD1=VD2=VD3=+3V and VG1=-0.45V, VG2=-0.35V, VG3=-0.45V, VG4=-1V

**Image Rejection versus IF at LO = 8GHz**  
(USB & LSB modes)

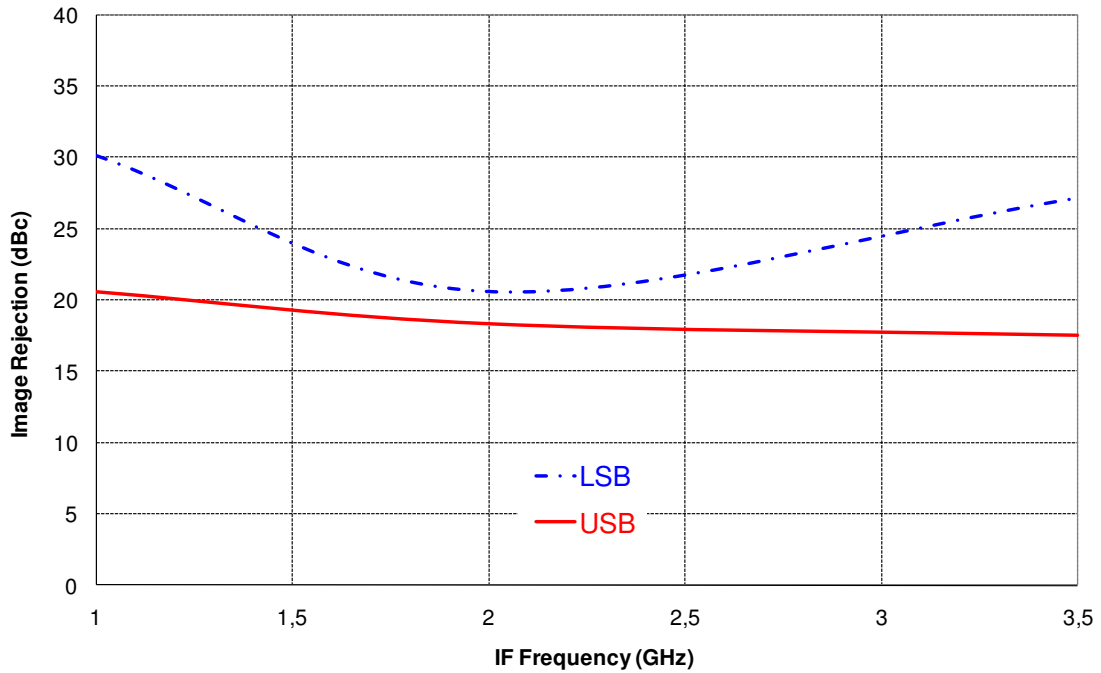

**Return Losses (LO & RF) versus frequency**

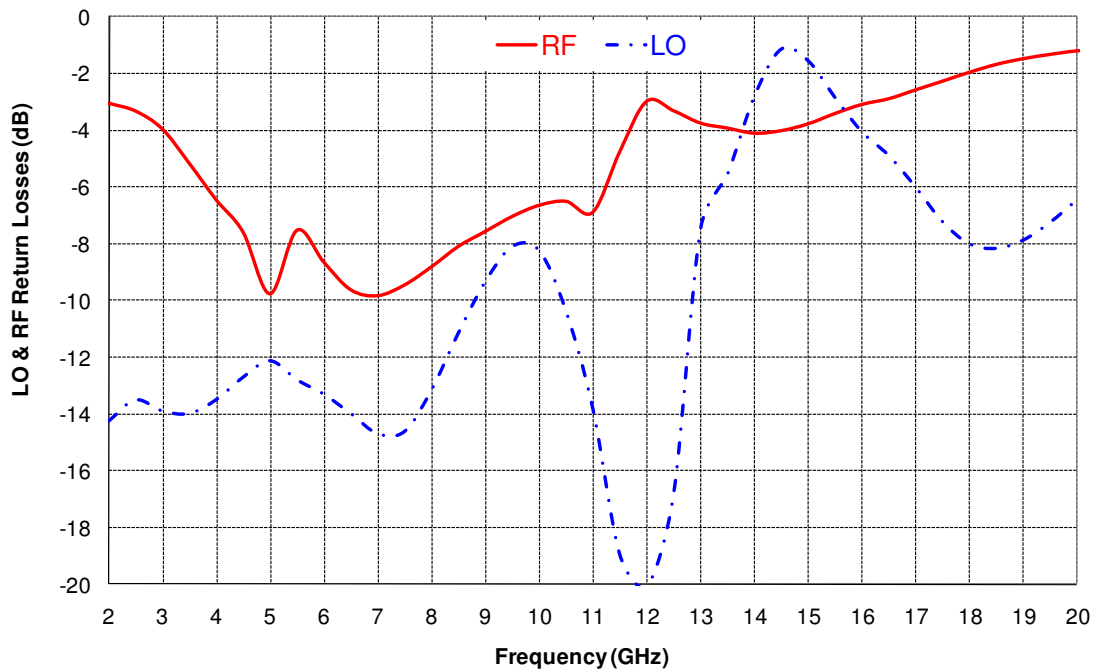

## Typical Board Measurements

Tamb.= +25°C, P\_LO = +5dBm

VD1=VD2=VD3=+3V and VG1=-0.45V, VG2=-0.35V, VG3=-0.45V, VG4=-1V

**Input IP3 vs RF frequency at IF = 1GHz**  
(LSB mode – 100mA)

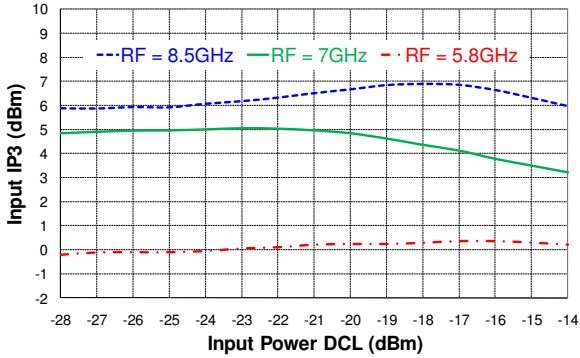

**Input IP3 vs RF frequency & DC Biasing, at IF = 1GHz**  
(LSB mode – RF = -20dBm per Tone)

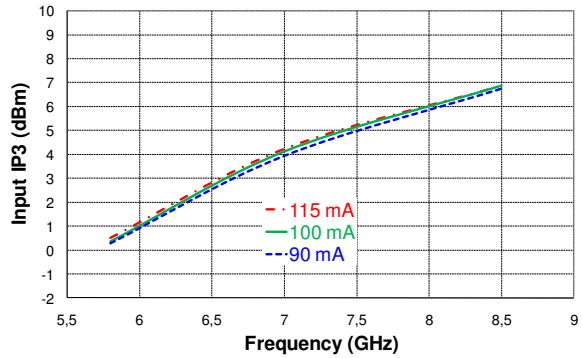

**Input IP3 vs RF frequency at IF = 1GHz**  
(USB mode – 100mA)

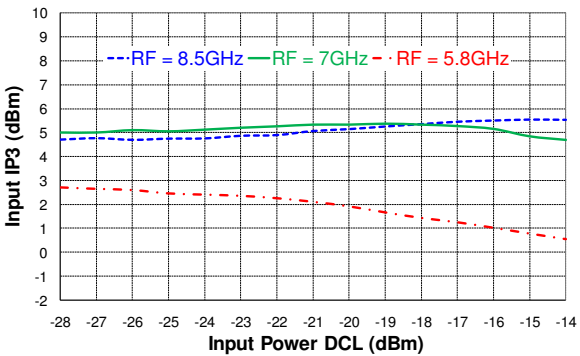

**Input IP3 vs RF frequency & DC Biasing, at IF = 1GHz**  
(USB mode – RF = -20dBm per Tone)

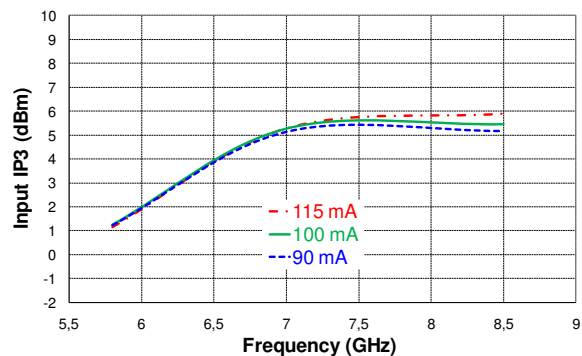

**Typical Board Measurements**

Tamb.= +25°C, P\_LO = +5dBm

VD1=VD2=VD3=+3V and VG1=-0.45V, VG2=-0.35V, VG3=-0.45V, VG4=-1V

**Conversion Gain versus temperature at IF = 1GHz**  
(LSB mode)

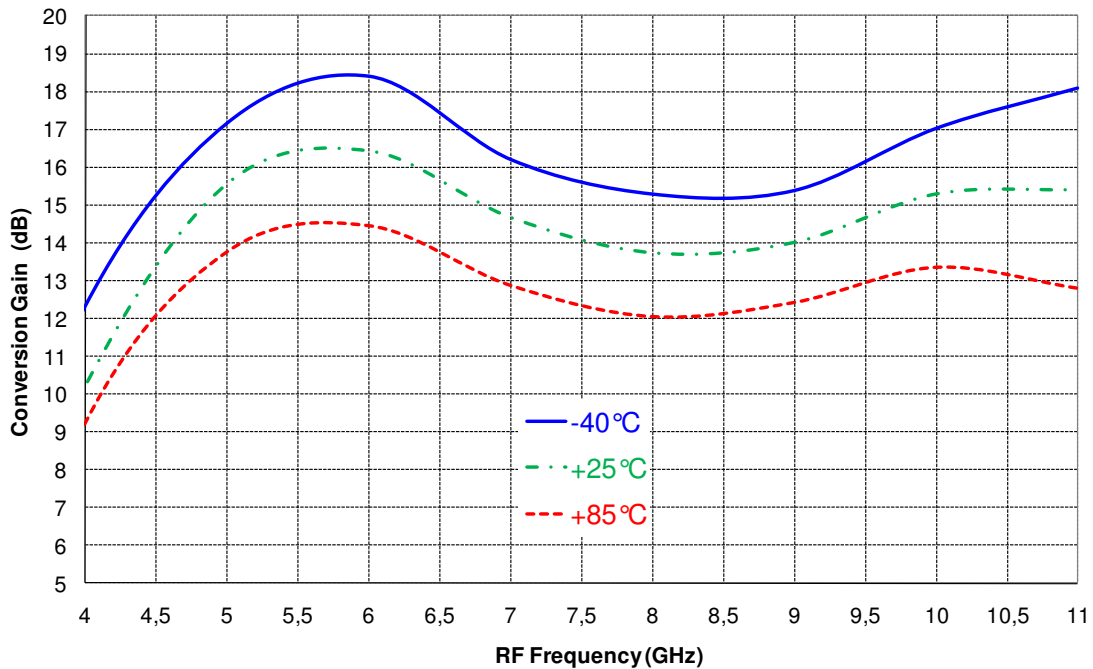

**Noise Figure versus temperature at IF = 1GHz**  
(LSB mode)

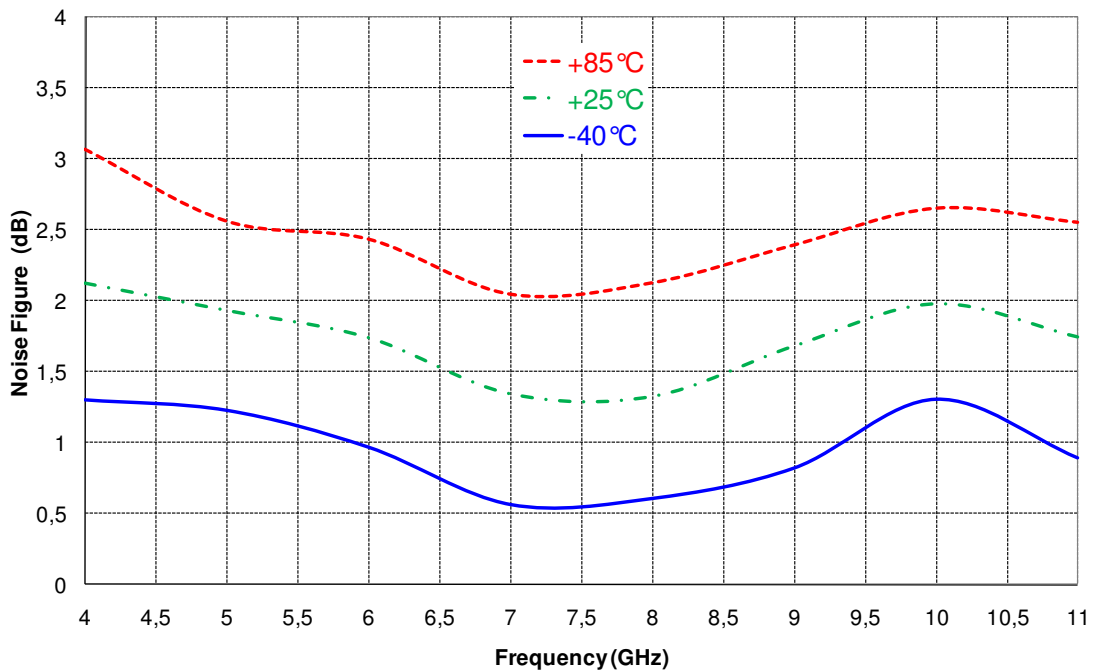

## Typical Board Measurements

Tamb.= +25°C, P\_LO = +5dBm

VD1=VD2=VD3=+3V and VG1=-0.45V, VG2=-0.35V, VG3=-0.45V, VG4=-1V

**Input IP3 vs temperature at IF = 1GHz**  
(LSB mode – RF = -20dBm per Tone)

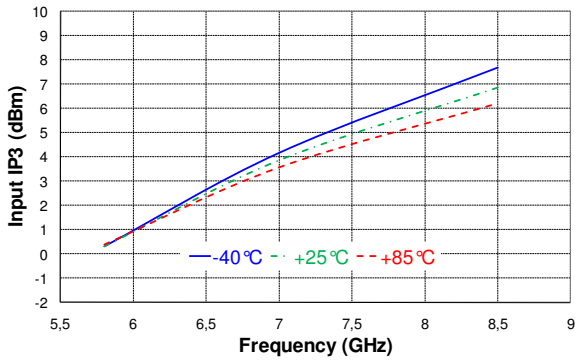

**IMD3 vs temperature at IF = 1GHz**  
(LSB mode – RF = 7GHz)

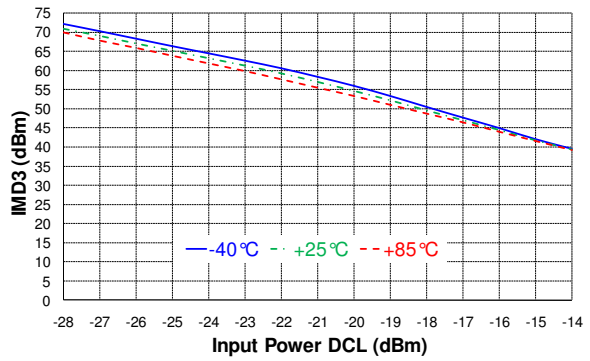

**Input IP3 vs temperature at IF = 1GHz**  
(USB mode – RF = -20dBm per Tone)

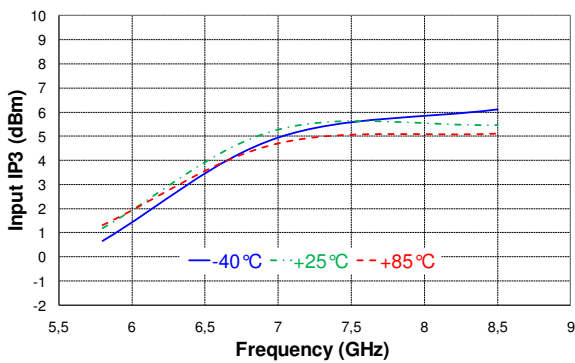

**IMD3 vs temperature at IF = 1GHz**  
(USB mode – RF = 7GHz)

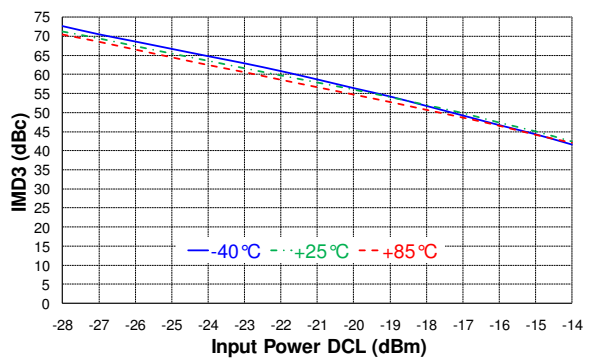

**Typical Board Measurements**T<sub>amb.</sub> = +25 °C, P<sub>LO</sub> = +5dBm

VD1=VD2=VD3=+3V and VG1=-0.45V, VG2=-0.35V, VG3=-0.45V, VG4=-1V

**Spurious on IF outputs**

RF = LO + IF

P<sub>RF</sub> = -20dBm @ 8.5GHz / P<sub>LO</sub> = 0dBm @ 7.5GHz

	nLO				
mRF	0	1	2	3	4
0	xx	14	32	40	45
1	19	0	39	56	47
2	77	70	34	52	67
3	<-90	<-90	<-90	61	68
4	<-90	<-90	<-90	<-90	<-90

All values in dBc below IF power level (IF = 1GHz).  
Data measured without external hybrid coupler.

## Package outline <sup>(1)</sup>

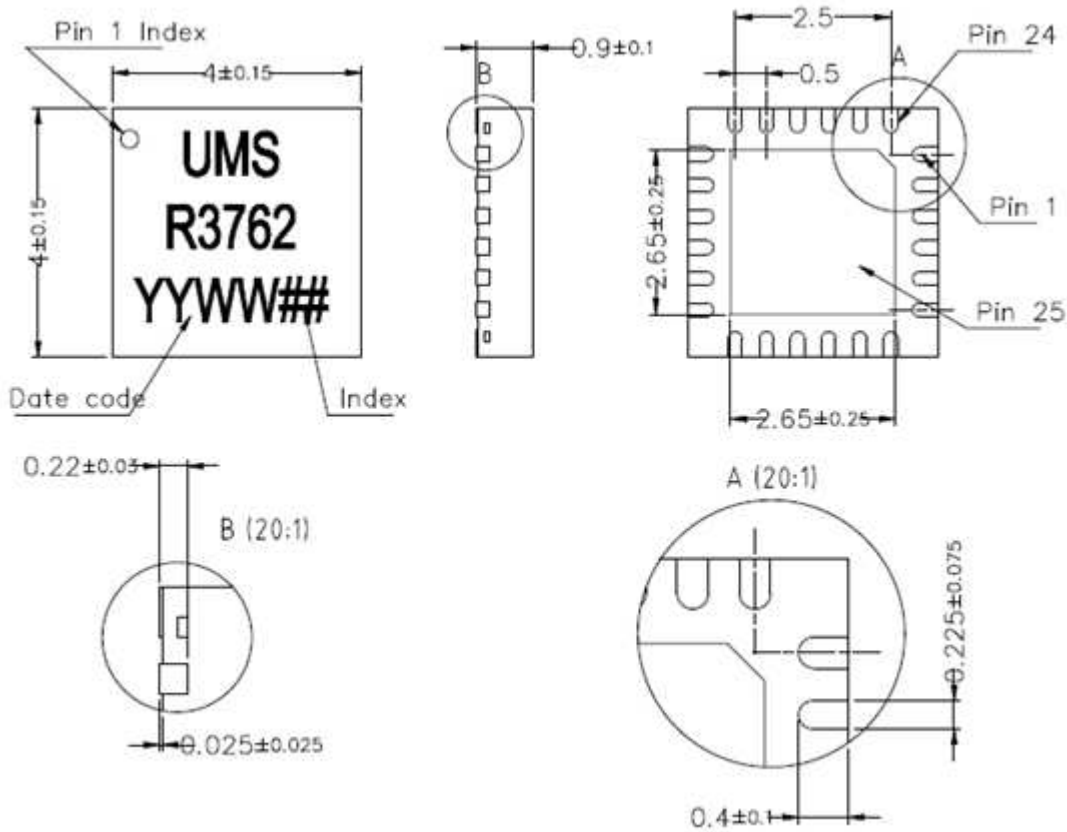

Matt tin, Lead Free (Green)	1- Nc	9- RF in	17- VG4
Units : mm	2- IF_Q	10- Gnd <sup>(2)</sup>	18- VD3
From the standard : JEDEC MO-220 (VGGD)	3- Gnd <sup>(2)</sup>	11- Nc	19- VG3
25- GND	4- Gnd <sup>(2)</sup>	12- VG1	20- Nc
	5- IF_I	13- VD1	21- Gnd <sup>(2)</sup>
	6- Nc	14- VG2	22- LO in
	7- Nc	15- VD2	23- Gnd <sup>(2)</sup>
	8- Gnd <sup>(2)</sup>	16- Nc	24- Nc

<sup>(1)</sup> The package outline drawing included in this data-sheet is given for indication. Refer to the application note AN0017 (<http://www.ums-gaas.com>) for exact package dimensions.

<sup>(2)</sup> It is strongly recommended to ground all pins marked "Gnd" through the PCB board. Ensure that the PCB board is designed to provide the best possible ground to the package.

**Evaluation mother board**

- Compatible with the proposed footprint.
- Based on typically Ro4003 / 8mils or equivalent.
- Using a micro-strip to coplanar transition to access the package.
- Recommended for implementation of this product on a module board.
- Decoupling capacitors of 100pF  $\pm$ 5% and 10nF  $\pm$ 10% are recommended for all DC accesses.
- See application note AN0017 for details.
- Hybrid coupler 90° for 1-2GHz.

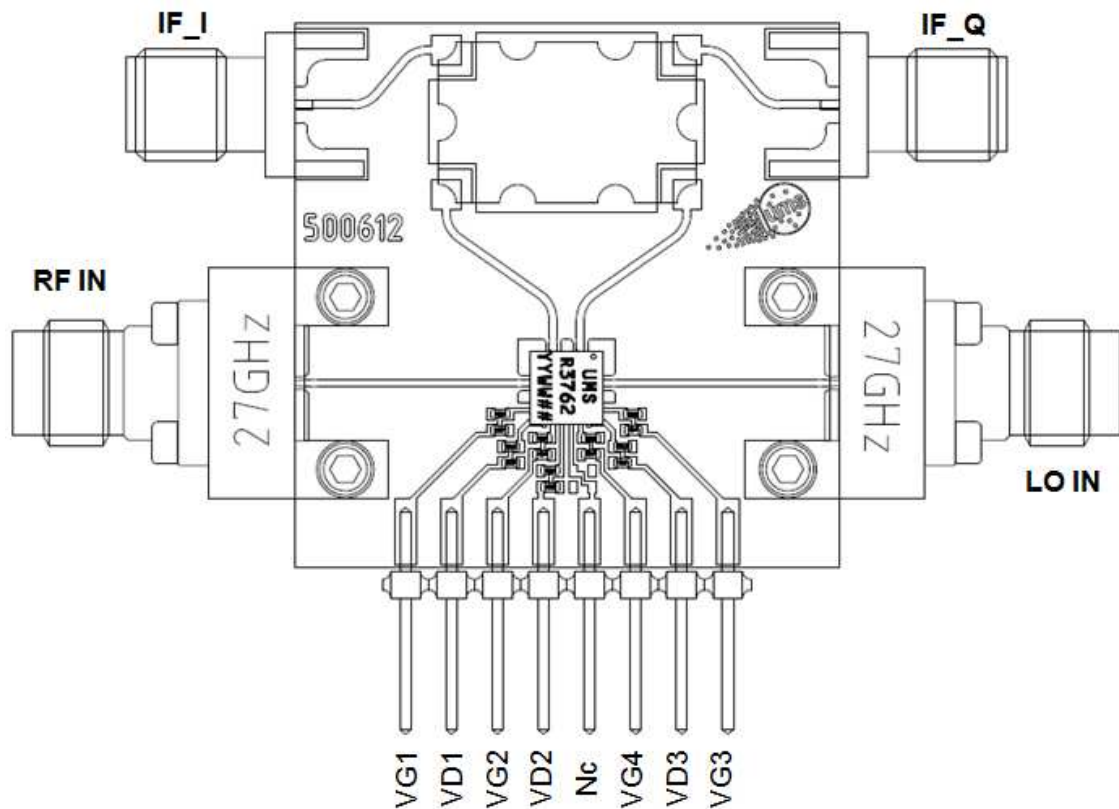

### Notes

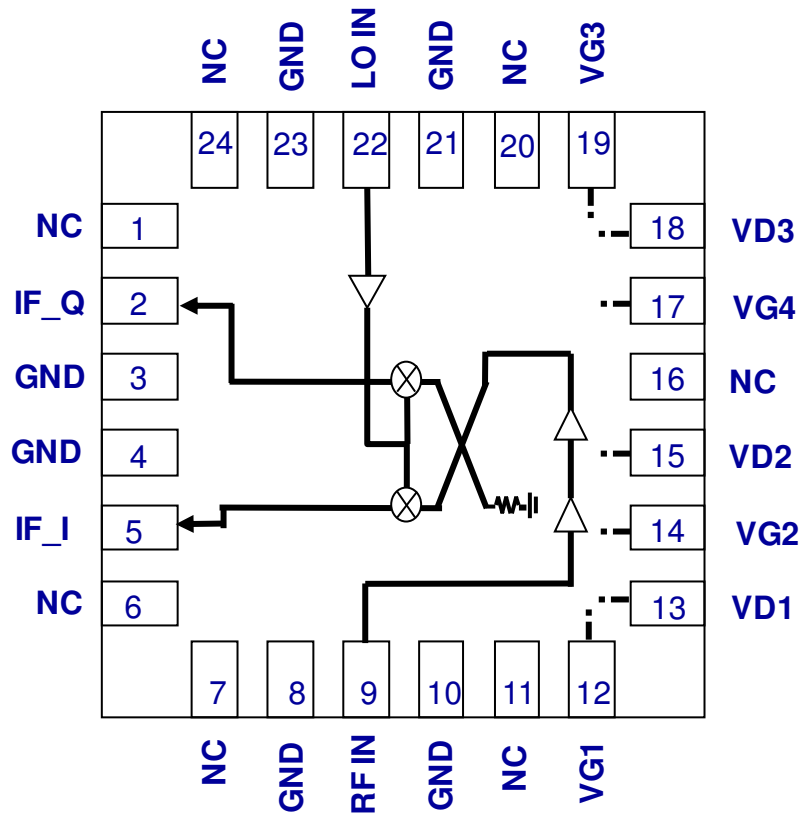

ESD protections are implemented on gate DC bias accesses.  
 The DC connections do not include any decoupling capacitor in package, therefore it is mandatory to provide a good external DC decoupling (100pF + 10nF) on the PC board, as close as possible to the package.

**DC Schematic**

**LNA: 3V, 62mA**

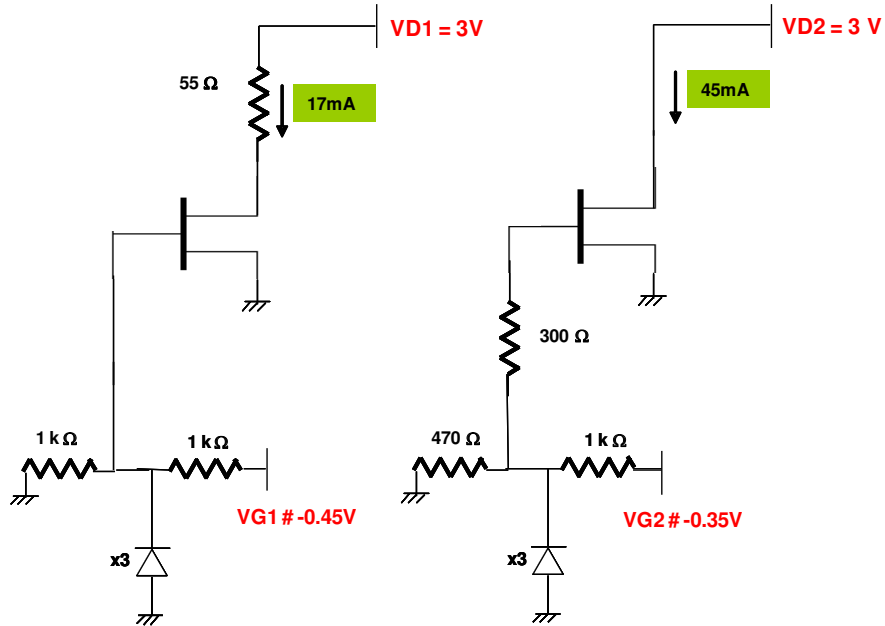

**LO Buffer: 3V, 38mA**

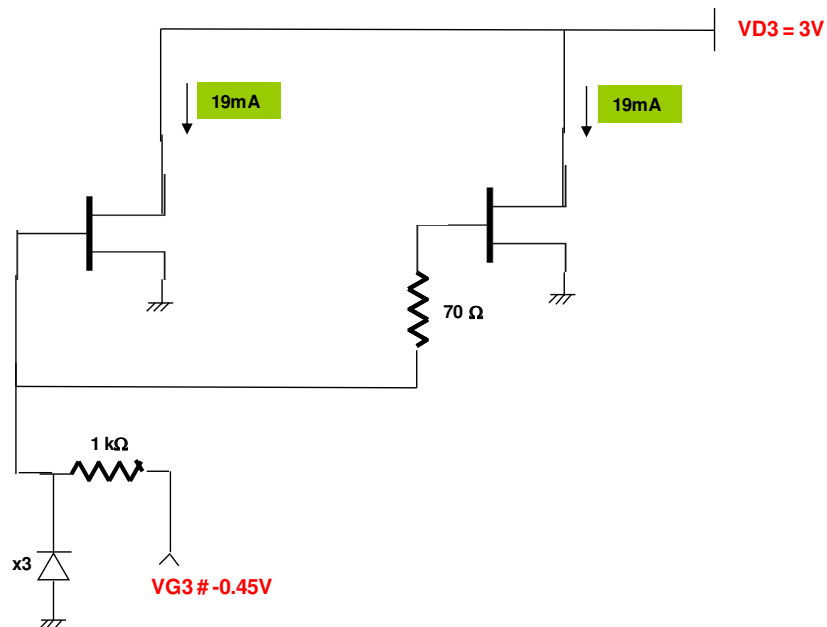

### **Recommended package footprint**

Refer to the application note AN0017 available at <http://www.ums-gaas.com> for package footprint recommendations.

### **SMD mounting procedure**

For the mounting process standard techniques involving solder paste and a suitable reflow process can be used. For further details, see application note AN0017.

### **Recommended environmental management**

UMS products are compliant with the regulation in particular with the directives RoHS N°2011/65 and REACH N°1907/2006. More environmental data are available in the application note AN0019 also available at <http://www.ums-gaas.com>.

### **Recommended ESD management**

Refer to the application note AN0020 available at <http://www.ums-gaas.com> for ESD sensitivity and handling recommendations for the UMS package products.

## **Ordering Information**

QFN 4x4 package:

CHR3762-QDG/XY

Stick: XY = 20

Tape & reel: XY = 21

Information furnished is believed to be accurate and reliable. However **United Monolithic Semiconductors S.A.S.** assumes no responsibility for the consequences of use of such information nor for any infringement of patents or other rights of third parties which may result from its use. No license is granted by implication or otherwise under any patent or patent rights of **United Monolithic Semiconductors S.A.S.** Specifications mentioned in this publication are subject to change without notice. This publication supersedes and replaces all information previously supplied. **United Monolithic Semiconductors S.A.S.** products are not authorised for use as critical components in life support devices or systems without express written approval from **United Monolithic Semiconductors S.A.S.**