

DC-12GHz ATTENUATOR

GaAs Monolithic Microwave IC in SMD leadless package

Description

The CHT3091aQAG is a variable DC-12GHz attenuator designed for a wide range of applications, from military to commercial communication systems.

It is supplied in lead-free SMD package.

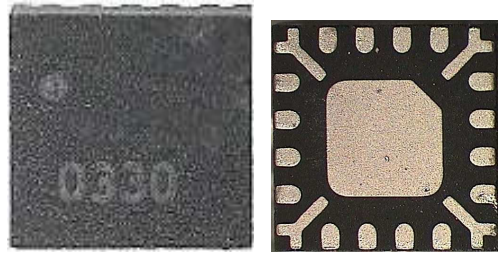

Main Features

- Broadband performances: DC-12GHz
- 15dBm typical input 1dB compression point (any attenuation)
- DC bias: $-5V < V_S < 0V$; $-5V < V_P < 0V$
- Package type: 16Leads QFN3x3

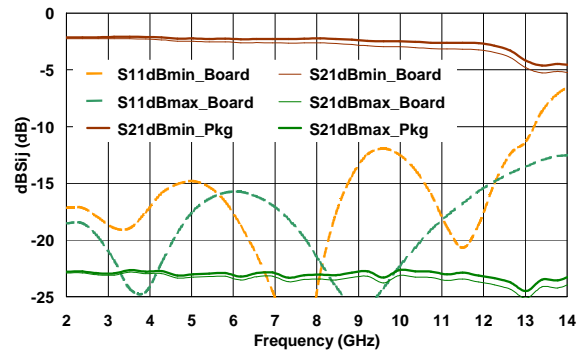

PCB Measured performances @ 20°C

Main Characteristics

Tamb. = 25°C

Symbol	Parameter	Min	Typ	Max	Unit
Fin	Input frequency range	DC		12	GHz
Min Att.	Minimum attenuation S21 (VS=0V;VP=-5V)		3	4	dB
Max Att.	Maximum attenuation S21 (VS=-5V;VP=0V)	20	23		dB
Pin1dB	Input 1dB compression point.(any Att)	14			dBm

ESD Protection: Electrostatic discharge sensitive device. Observe handling precautions!

Main Characteristics

Tamb. = 25°C

Symbol	Parameter	Min	Typ	Max	Unit
Fin	Input frequency range	DC		12	GHz
Min Att.	Minimum attenuation S21 (VS=0V;VP=-5V)		3.0	4.0	dB
Max Att.	Maximum attenuation S21 (VS=-5V;VP=0V)	20	23		dB
VSWRin	Input VSWR (any attenuation)		2.:1		
VSWRout	Output VSWR (any attenuation)		2.:1		
Pin1dB	Input 1dB compression point.(any attenuation)	14	15		dBm

These values are representative of onboard measurements as defined in the application section.

ESD Protection: Electrostatic discharge sensitive device. Observe handling precautions!

Absolute Maximum Ratings

Tamb. = 25°C ⁽¹⁾

Symbol	Parameter	Values	Unit
VP	VP control voltage	-6V to +0.6V	V
VS	VS control voltage	-6V to +0.6V	V
Pin	RF input power	20	dBm
Ta	Operating temperature range	-40 to +85	°C
Tstg	Storage temperature range	-55 to +155	°C

(1) Operation of this device above anyone of these parameters may cause permanent damage.

Typical Bias Conditions

For an ambient Temperature of +25°C

Symbol	Pin No.	Parameter	Values	Unit
Vs	6	VS control voltage	-5 to 0	V
Vp	7	VP control voltage	0 to -5	V

All other pins are not used for this device (but RFin: pin 2 and RFout: pin 11).

Demonstration Board (PCB)

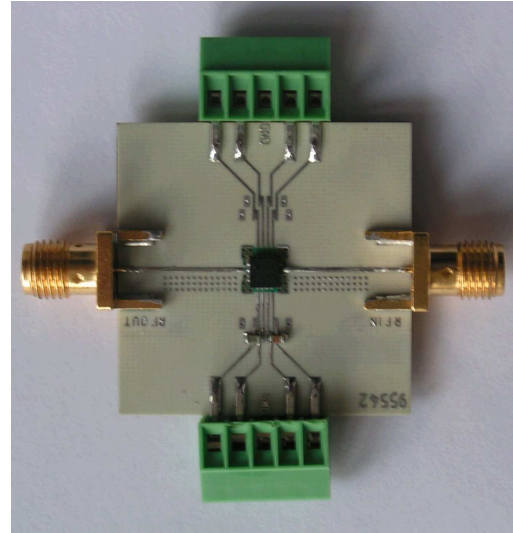
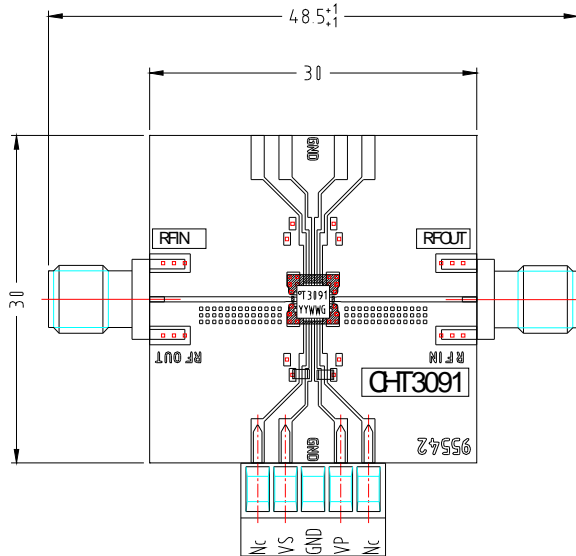

Typical Results

Tamb = +25°C
 Vp = 0V to -5V & Vs = -5V to 0V

PCB Measured Performance
 (T amb. 25°C)

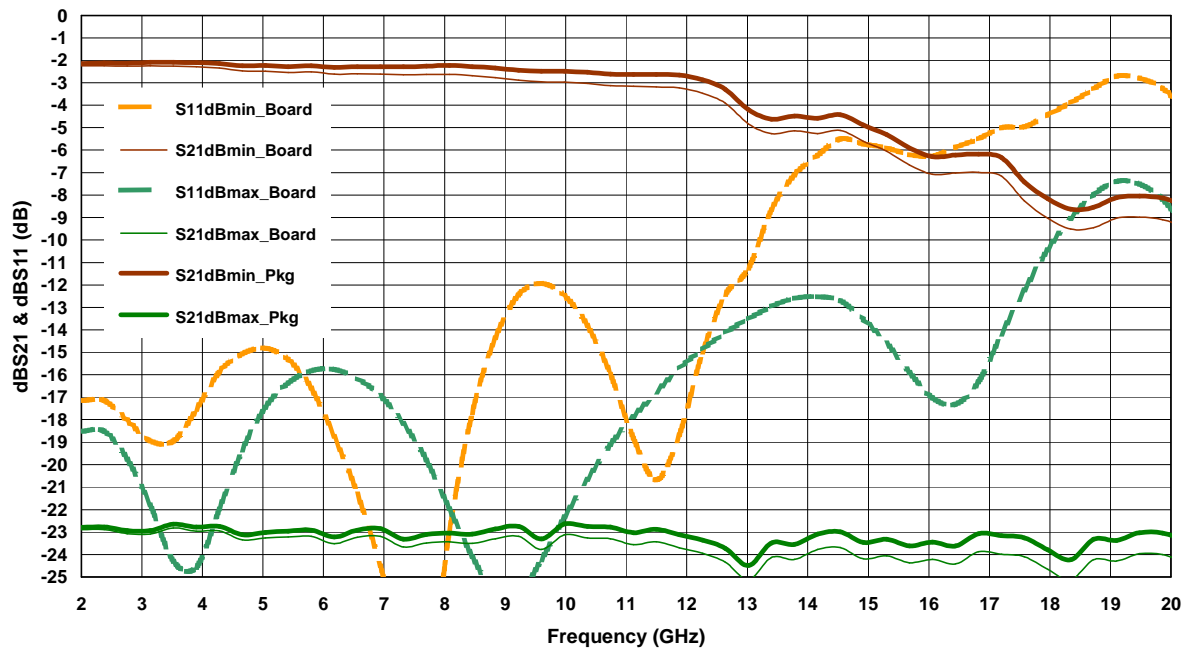

Application note

The design of the motherboard has a strong impact on the over all performance since the transition from the motherboard to the package is comparably large. In case of the SMD type packages of United Monolithic Semiconductors the motherboard should be designed according to the information given in the following to achieve good performance. Other configurations are also possible but can lead to different results. If you need advise please contact United Monolithic Semiconductors for further information.

SMD type packages of UMS should allow design and fabrication of micro- and mm-wave modules at low cost. Therefore, a suitable motherboard environment has been chosen. All tests and verifications have been performed on Rogers RO4003. This material exhibits a permittivity of 3.38 and has been used with a thickness of 200 μ m [8 mils] and a 1/2oz or less copper cladding. The corresponding 50Ohm transmission line has a strip width of about 460 μ m [approx. 18 mils].

The contact areas on the motherboard for the package connections should be designed according to the footprint given above. The proper via structure under the ground pad is very important in order to achieve a good RF and lifetime performance. All tests have been done by using a grid of plenty plated through vias with a diameter of less than 200 μ m [8 mils] and a spacing of less than 400 μ m [16 mils] from the centres of two adjacent vias. The via grid should cover the whole space under the ground pad and the vias closest to the RF ports should be located near the edge of the pad to allow a good RF ground connection. Since the vias are important for heat transfer, a proper via filling should be guaranteed during the mounting procedure to get a low thermal resistance between package and heat sink. For power devices the use of heat slugs in the motherboard instead of a grid of via's is recommended.

For the mounting process the SMD type package can be handled as a standard surface mount component. The use of either solder or conductive epoxy is possible. The solder thickness after reflow should be typical 50 μ m [2 mils] and the lateral alignment between the package and the motherboard should be within 50 μ m [2 mils]. Caution should be taken to obtain a good and reliable contact over the whole pad areas. Voids or other improper connections, in particular, between the ground pads of motherboard and package will lead to a deterioration of the RF performance and the heat dissipation. The latter effect can reduce drastically reliability and lifetime of the product.

Package outline:

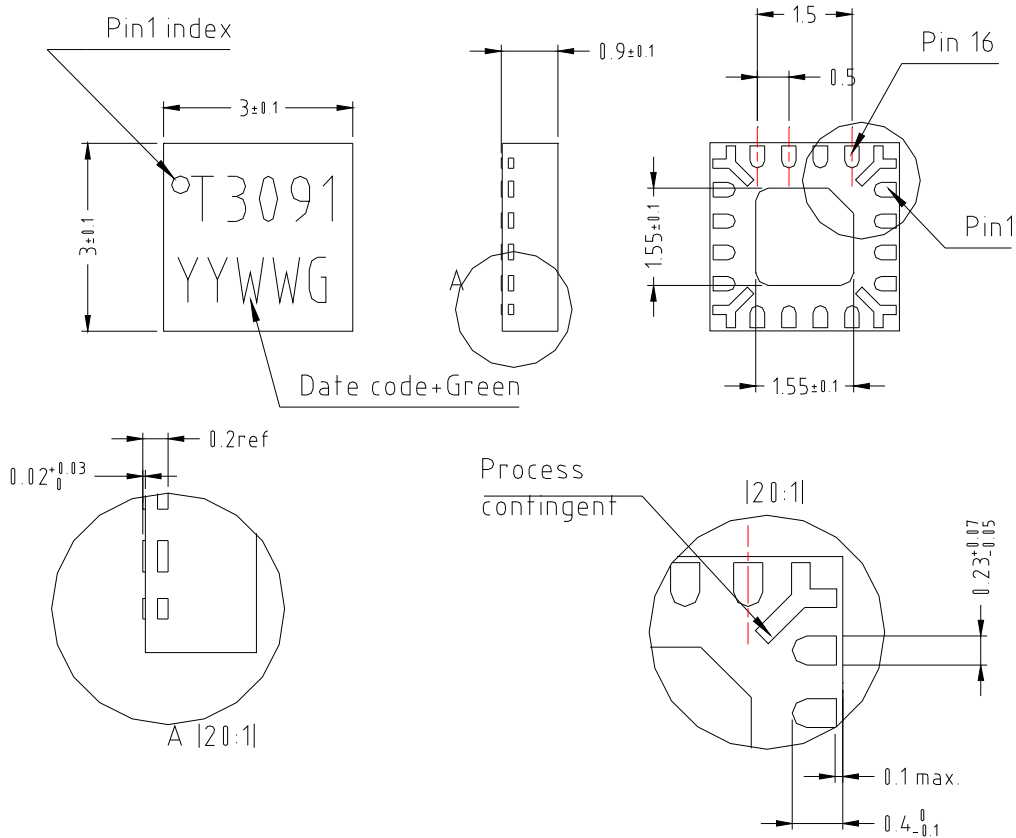

Matt tin, Lead free (Green)

Units : mm

From the standard : JEDEC MO-220

Subject to change without notice

- | | |
|----------|------------|
| 1- Gnd | 9- Nc |
| 2- RF In | 10- Gnd |
| 3- Gnd | 11- RF Out |
| 4- Nc | 12- Gnd |
| 5- Nc | 13- Nc |
| 6- Vs | 14- Nc |
| 7- Vp | 15- Nc |
| 8- Nc | 16- Nc |

Ordering Information

QFN 3x3 RoHS compliant package:

CHT3091aQAG/XY

Stick: XY = 20

Tape & reel: XY = 21

Information furnished is believed to be accurate and reliable. However **United Monolithic Semiconductors S.A.S.** assumes no responsibility for the consequences of use of such information nor for any infringement of patents or other rights of third parties which may result from its use. No license is granted by implication or otherwise under any patent or patent rights of **United Monolithic Semiconductors S.A.S.**. Specifications mentioned in this publication are subject to change without notice. This publication supersedes and replaces all information previously supplied. **United Monolithic Semiconductors S.A.S.** products are not authorised for use as critical components in life support devices or systems without express written approval from **United Monolithic Semiconductors S.A.S.**