

DC-6GHz 6-BIT DIGITAL ATTENUATOR

GaAs Monolithic Microwave IC

Description

The CHT4012-98F is a DC-6GHz monolithic 6 bit digital attenuator with a LSB = 0.5dB offering a high dynamic range and a high accuracy, the RMS amplitude error is typically as low as 0.3dB. The circuit provides low insertion loss 2.5dB associated to input and output return losses better than 14dB. A CMOS and TTL compatible interface is available on chip.

The circuit is mainly dedicated to defence and space systems and is also well suited for a wide range of microwave applications and systems.

The circuit is manufactured with a pHEMT process, 0.25µm gate length and electron beam gate lithography.

It is available in chip form

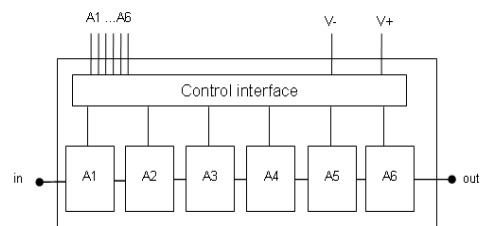

Main Features

- Broadband performances: DC-6GHz
- Insertion Loss (state 0): 2.5dB
- RMS attenuation error: 0.3dB
- RMS phase variation: 1deg
- DC bias: V+=5V and V--5V
- No decoupling capacitance on Input and Output RF accesses
- Chip size 2.41x1.41x0.1mm

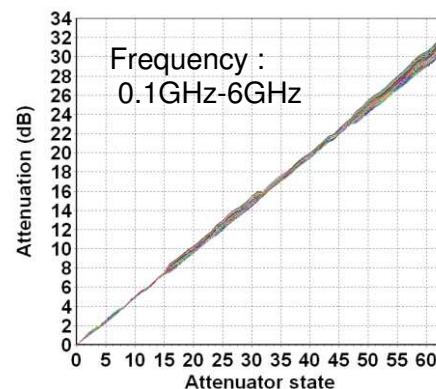

Main Characteristics

Tamb.= +25°C

Symbol	Parameter	Min	Typ	Max	Unit
Freq	Frequency range	DC		6	GHz
IL	Insertion Loss		2.5		dB
Rms_att_er	RMS of attenuation error		0.3		dB
Rms_phivar	RMS of phase variation (0.1 to 6GHz)		1		°

Main Characteristics

Tamb.= +25°C

Symbol	Parameter	Min	Typ	Max	Unit
Freq	Operating frequency	DC		6	GHz
IL	Insertion Loss		2.5		dB
S11	Input Return Loss		-16		dB
S22	Output Return Loss		-14		dB
P1dB	Input power at 1dB gain compression		20		dBm
Dyn	Dynamic		31.5		dB
LSB	Attenuator elementary step		0.5		dB
Att_er	Attenuation error		-0.5/+0.5		dB
Rms_att_er	RMS of attenuation error		0.3		dB
Phivar	Phase variation (0.1 to 6GHz)		-5 / +1		°
Rms_phivar	RMS of phase variation (0.1 to 6GHz)		1		°
V+	Positive supply voltage		5		V
V-	Negative supply voltage		-5	-4	V
Vctrl_L	Control voltage low level		0	0.4	V
Vctrl_H	Control voltage high level	2.4		7	V
I_V+	Positive supply DC current		5		mA
I_V-	Negative supply DC current		5		mA

These values are representative of measurements in test fixture

Definitions

n: Attenuator state index with $0 \leq n \leq 63$

Phase_S21(n): Measured phase of S21 in degree at attenuation state n

dB_S21(n): Measured magnitude of S21 in dB at attenuation state n

Attenuation Error (Att_err)

$$\text{Att_err}(n) = \text{dB_S21}(n) - \text{dB_S21}(0) - 0.5 \cdot n \text{ (dB)}$$

The translation of Att_err(i) from dB to linear is given by: $\text{Att_err_lin}(n) = 10^{\frac{\text{Att_err}(n)}{20}}$

Phase variation (Phivar)

$$\text{Phivar}(n) = \text{Phase_S21}(n) - \text{Phase_S21}(0) \text{ (}^\circ\text{)}$$

RMS Attenuation Error (Rms_att)

$$\text{Rms_att} = 20 \log \left(1 + \sqrt{\frac{1}{64} \cdot \sum_{n=0}^{63} (1 - \text{Att_err_lin}(n))^2} \right) \text{ (dB)}$$

RMS Phase variation (Rms_Phivar)

$$\text{Rms_Phivar} = \sqrt{\frac{\sum_{n=0}^{63} (\text{Phivar}(n))^2}{64}} \text{ (}^\circ\text{)}$$

Absolute Maximum Ratings ⁽¹⁾

T_{amb.} = +25 °C

Symbol	Parameter	Values	Unit
V+	Maximum positive bias voltage	8	V
V-	Minimum negative bias voltage	-8	V
Ai	CTRL voltage (Vctrl_low, Vctrl_high)	-2, 8	V
Pin	Maximum Input power	23	dBm
Tj	Junction temperature	175	°C
Ta	Operating temperature range	-40 to +85	°C
Tstg	Storage temperature range	-55 to +150	°C

⁽¹⁾ Operation of this device above any one of these parameters may cause permanent damage.

Typical on-wafer Sij parameters at State 0

Tamb.= +25°C, V+ = +5V, V-=-5V

Freq (GHz)	S11 (dB)	PhS11 (°)	S12 (dB)	PhS12 (°)	S21 (dB)	PhS21 (°)	S22 (dB)	PhS22 (°)
0.2	-20.21	0.1	-1.69	-5.6	-1.69	-5.6	-20.37	-0.3
0.4	-20.33	-9.2	-1.75	-9.9	-1.75	-9.9	-20.27	-8.8
0.6	-20.90	-20.2	-1.81	-14.2	-1.82	-14.1	-20.25	-18.0
0.8	-20.77	-32.0	-1.87	-18.3	-1.88	-18.3	-19.96	-27.4
1.0	-20.75	-40.7	-1.90	-22.5	-1.90	-22.6	-19.67	-35.5
1.2	-20.45	-48.7	-1.93	-26.7	-1.94	-26.8	-19.33	-41.9
1.4	-20.59	-54.5	-1.97	-30.9	-1.98	-31.0	-19.26	-48.4
1.6	-20.92	-61.5	-2.03	-35.2	-2.04	-35.3	-19.21	-55.4
1.8	-21.15	-69.9	-2.07	-39.4	-2.07	-39.6	-19.08	-60.8
2.0	-21.24	-77.4	-2.11	-43.7	-2.11	-43.8	-18.96	-65.8
2.2	-21.34	-84.7	-2.15	-47.8	-2.15	-47.8	-18.86	-70.0
2.4	-21.48	-90.7	-2.21	-52.0	-2.21	-52.1	-18.60	-74.1
2.6	-21.80	-94.9	-2.25	-56.1	-2.25	-56.3	-18.46	-78.1
2.8	-22.62	-100.6	-2.30	-60.3	-2.30	-60.4	-18.30	-81.8
3.0	-23.17	-106.8	-2.35	-64.5	-2.35	-64.6	-18.26	-84.9
3.2	-23.97	-113.1	-2.40	-68.7	-2.40	-68.7	-18.19	-88.0
3.4	-24.56	-120.1	-2.44	-72.8	-2.44	-72.9	-17.92	-90.8
3.6	-25.40	-123.3	-2.49	-76.9	-2.49	-76.9	-17.75	-93.7
3.8	-26.78	-125.4	-2.54	-81.0	-2.54	-81.1	-17.59	-95.7
4.0	-28.80	-125.6	-2.59	-85.1	-2.60	-85.2	-17.52	-97.8
4.2	-31.95	-128.2	-2.62	-89.3	-2.63	-89.3	-17.34	-99.0
4.4	-35.79	-128.9	-2.69	-93.4	-2.69	-93.5	-17.22	-100.4
4.6	-42.02	-100.1	-2.74	-97.6	-2.72	-97.6	-17.00	-101.1
4.8	-42.57	-39.9	-2.79	-101.7	-2.79	-101.8	-16.68	-102.1
5.0	-34.86	-19.8	-2.84	-105.9	-2.84	-105.9	-16.44	-103.6
5.2	-30.17	-9.9	-2.89	-109.9	-2.90	-110.1	-16.17	-104.5
5.4	-27.13	-7.3	-2.96	-114.1	-2.95	-114.1	-16.03	-105.6
5.6	-24.54	-5.9	-3.03	-118.3	-3.02	-118.4	-15.72	-107.0
5.8	-22.91	-7.6	-3.07	-122.5	-3.08	-122.6	-15.40	-108.7
6.0	-21.40	-11.8	-3.14	-126.6	-3.14	-126.6	-15.05	-109.6
6.2	-20.12	-17.1	-3.21	-130.6	-3.21	-130.8	-14.69	-111.4
6.4	-18.82	-22.2	-3.28	-134.8	-3.27	-134.9	-14.38	-112.5
6.6	-17.69	-24.7	-3.35	-138.9	-3.35	-139.1	-14.00	-114.3
6.8	-16.78	-28.2	-3.41	-143.1	-3.41	-143.1	-13.77	-116.3
7.0	-16.01	-30.9	-3.49	-147.2	-3.49	-147.3	-13.35	-117.8
7.2	-15.35	-34.9	-3.56	-151.4	-3.56	-151.4	-13.05	-120.4
7.4	-14.54	-38.7	-3.65	-155.5	-3.63	-155.6	-12.73	-122.3
7.6	-13.93	-42.1	-3.71	-159.5	-3.71	-159.6	-12.36	-124.7
7.8	-13.18	-46.1	-3.77	-163.6	-3.77	-163.8	-12.13	-127.3
8.0	-12.71	-48.8	-3.87	-167.8	-3.87	-168.0	-11.82	-129.9

Typical Measurements in test fixture:

[S] parameters

T= +25°C, V+ = +5V, V- = -5V

S21 versus Frequency
Attenuator state 0

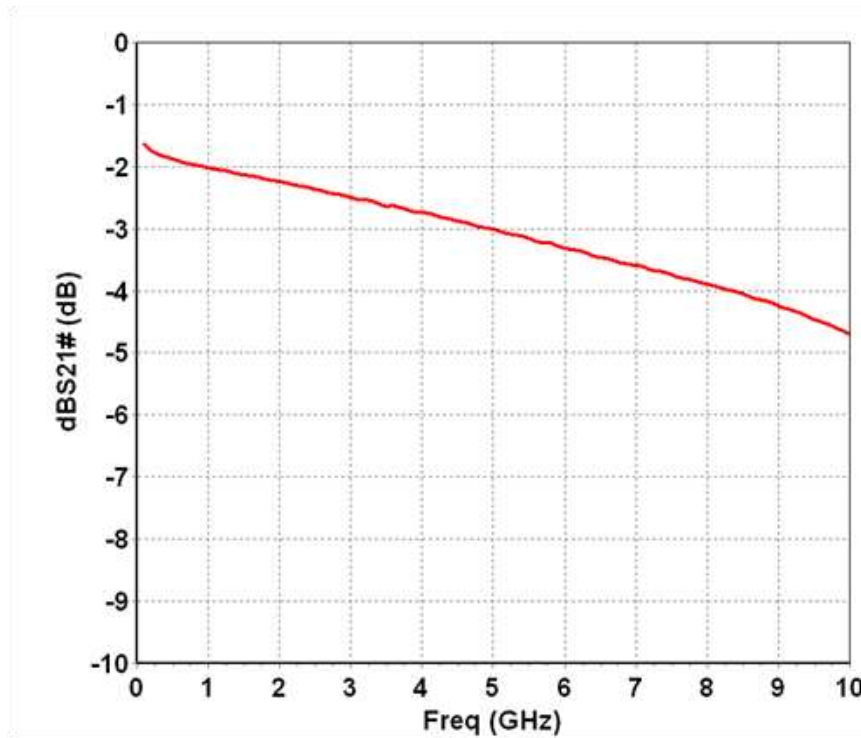

S11 versus Frequency
All attenuator states

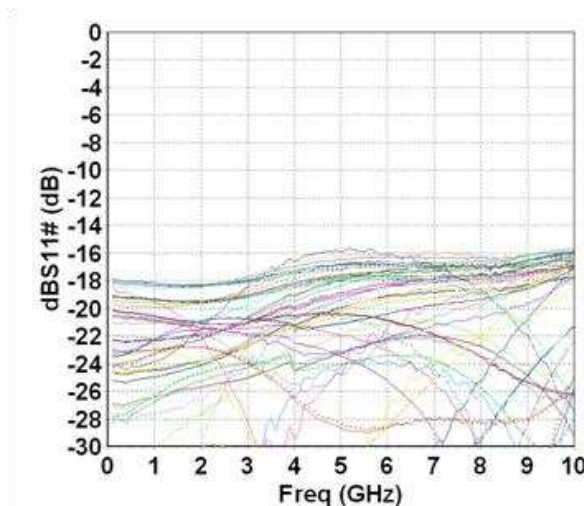

S22 versus Frequency
All attenuator states

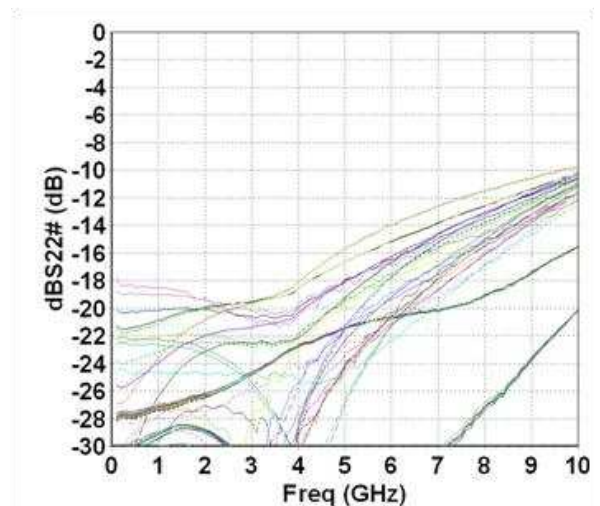

Typical Measurements in test fixture:

Attenuator performances: Attenuation error

T= +25°C, V+ = +5V, V- = -5V

Attenuation error versus frequency
All attenuator states

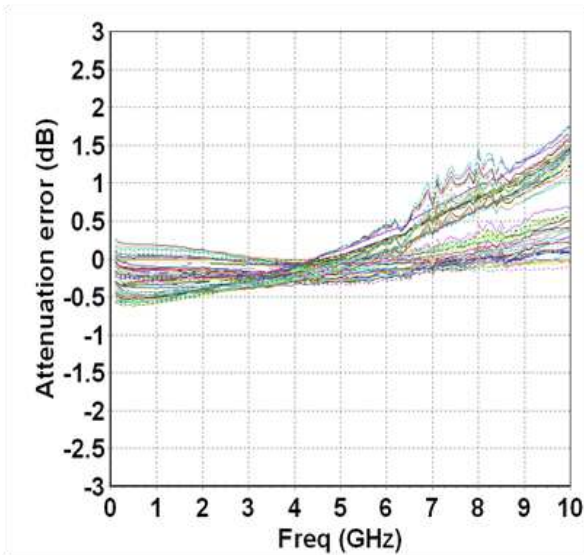

Attenuation error versus Attenuator state
0.1GHz < Freq. < 6GHz

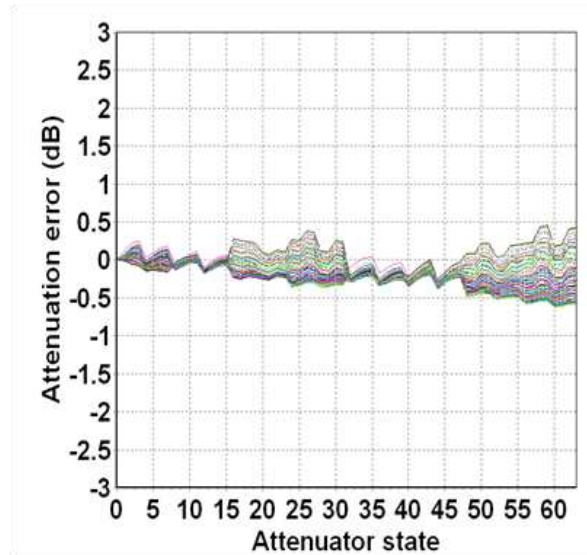

RMS Attenuation error

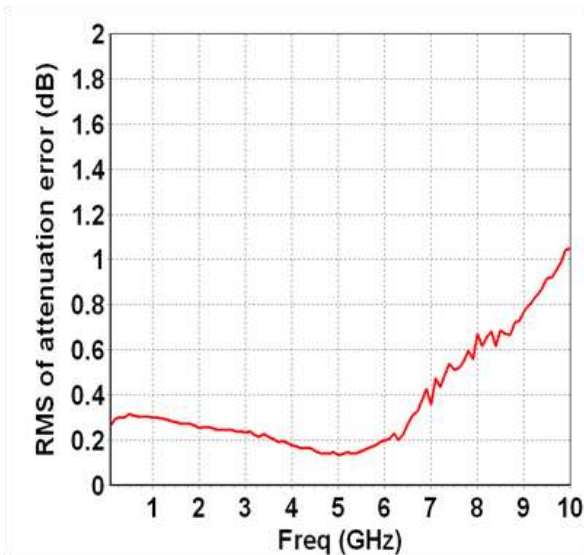

Attenuation versus Attenuator state
0.1GHz < Freq. < 6GHz

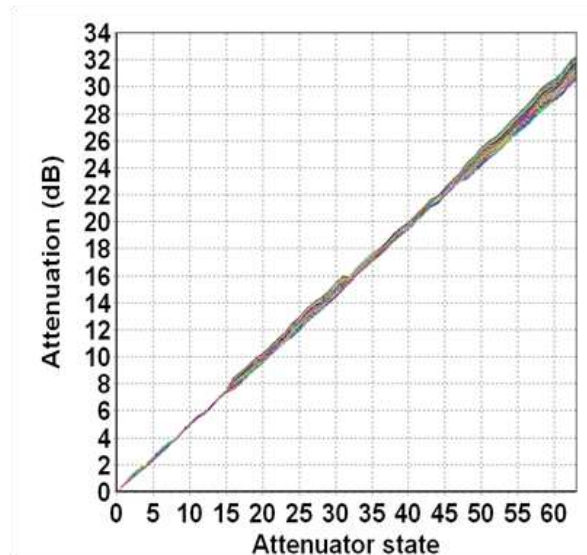

Typical Measurements in test fixture:

Attenuator performances: Phase variation

T= +25°C, V+ = +5V, V- = -5V

RMS of Phase variation

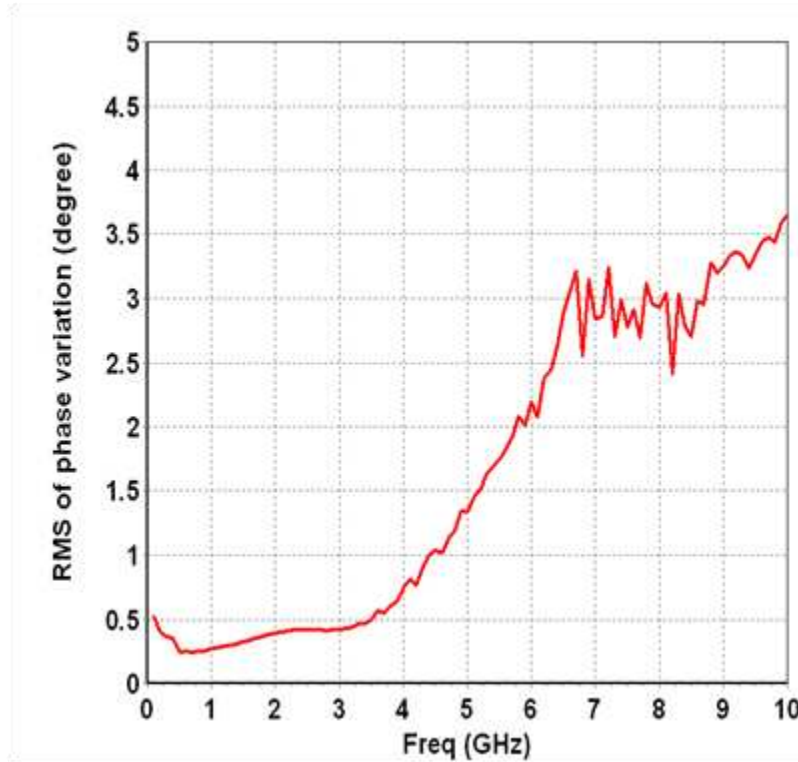

Phase variation versus Frequency

All attenuator states

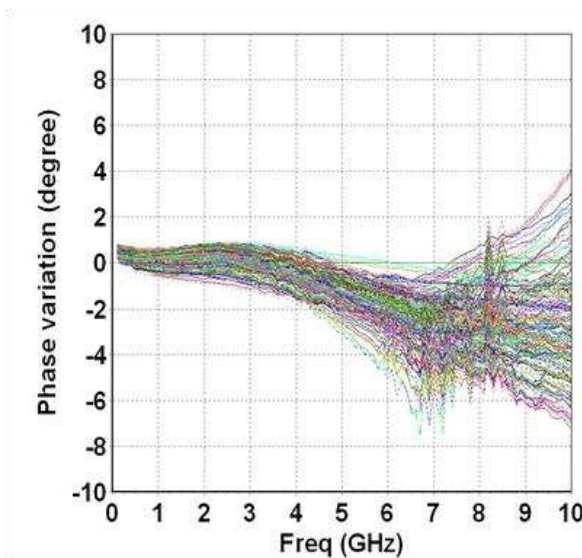

Phase variation versus Attenuator state

0.1GHz < Freq. < 6GHz

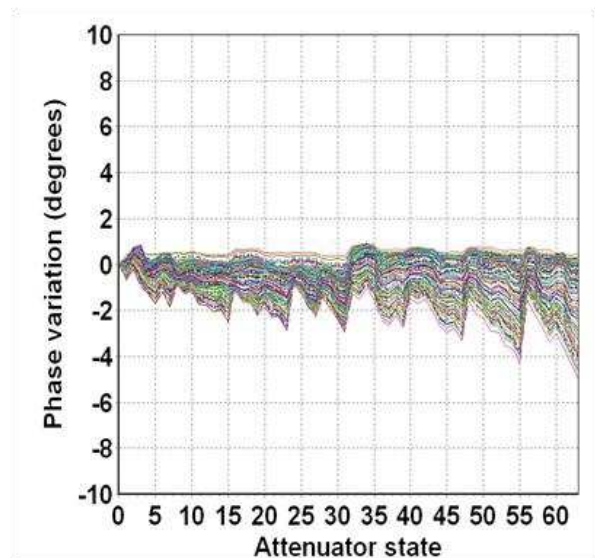

Typical Measurements in test fixture:

Attenuator performances: Phase variation

T= +25°C, V+ = +5V, V- = -5V

Variation of the Gain versus Frequency

Attenuator states: 0 / 1 / 2 / 4 / 8 / 16 / 32 / 63

Input power: -5 to 22dBm

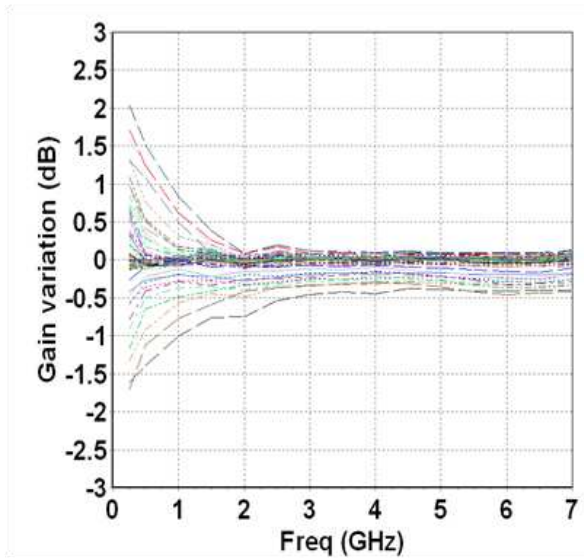

Variation of the gain versus Input power

Attenuator states: 0 / 1 / 2 / 4 / 8 / 16 / 32 / 63

Frequency: 0.25GHz to 6GHz

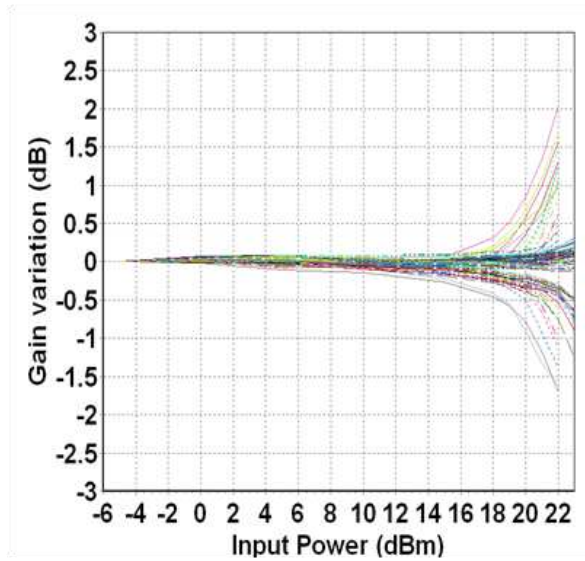

Mechanical dimensions and pad allocation

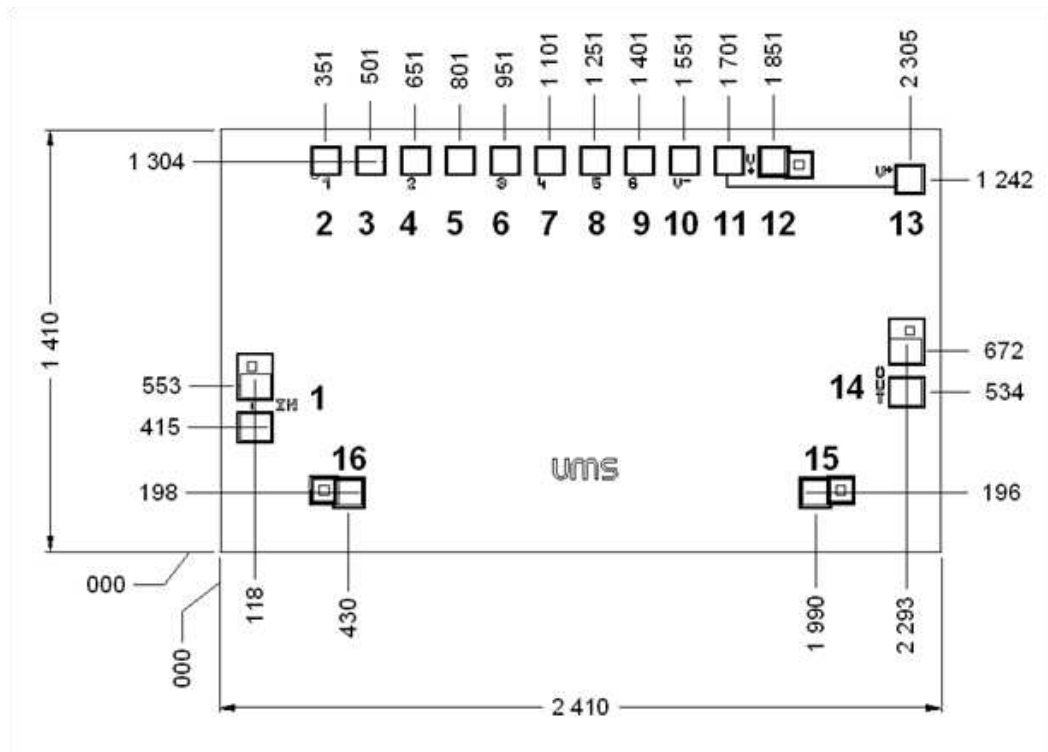

Chip thickness = $100\mu\text{m} \pm 10\mu\text{m}$.

RF pads (1, 14) = $122 \times 100\mu\text{m}^2$

DC and control pads (2, 4, 6, 7, 8, 9, 10, 13, 12, 15, 16) = $100 \times 100\mu\text{m}^2$

Pin number	Pad name	Description
1	IN	Input RF:
2	A1	Attenuator bit 1
4	A2	Attenuator bit 2
6	A3	Attenuator bit 3
7	A4	Attenuator bit 4
8	A5	Attenuator bit 5
9	A6	Attenuator bit 6
10	V-	-5V supply voltage: interface
13	V+	+5V supply voltage: interface ⁽¹⁾
14	OUT	Output RF
3, 5		NC
11	V+	NC ⁽¹⁾
12, 15, 16	GND	NC

⁽¹⁾ Pin n°11 is internally connected to Pin n°13. Each one of these pins can be indifferently used to supply the control interface with +5V

Bonding recommendations

Port	Connection
IN (1) OUT (14)	Inductance (L _{bonding}) = 0.3nH one wire: diameter 25µm, length 0.4mm
DC and Interface pads	Inductance (L _{bonding}) = 0.8nH one wire: diameter 25µm, length 1.0mm

Recommended assembly diagram

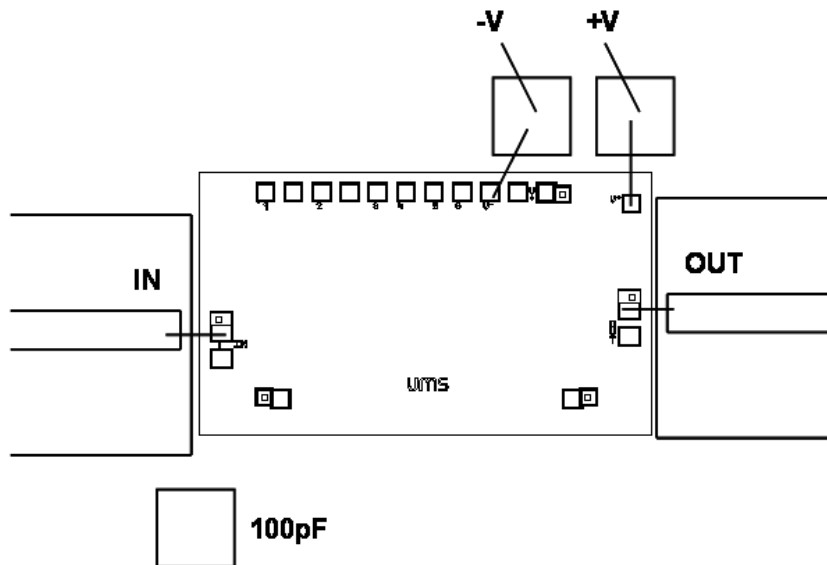

Note:

An external capacitance is requested to protect the device from any external DC voltage that might be present on the RF accesses.

Bonding recommendations

Pin number	Pad name	Value
2	A1	0V / 3.3V or 0V / 5V
4	A2	0V / 3.3V or 0V / 5V
6	A3	0V / 3.3V or 0V / 5V
7	A4	0V / 3.3V or 0V / 5V
8	A5	0V / 3.3V or 0V / 5V
9	A6	0V / 3.3V or 0V / 5V
10	V-	-5V
13	V+	+5V

NOTE:

Control voltages of the attenuator bits are both CMOS and TTL compatible

Attenuator control table

Voltage to apply on the pads A1 to A6:

state	Att (dB)	A6	A5	A4	A3	A2	A1	state	Att (dB)	A6	A5	A4	A3	A2	A1
0	0	0	0	0	0	0	0	33	16.5	3.3	0	0	0	0	3.3
1	0.5	0	0	0	0	0	3.3	34	17	3.3	0	0	0	3.3	0
2	1	0	0	0	0	3.3	0	35	17.5	3.3	0	0	0	3.3	3.3
3	1.5	0	0	0	0	3.3	3.3	36	18	3.3	0	0	3.3	0	0
4	2	0	0	0	3.3	0	0	37	18.5	3.3	0	0	3.3	0	3.3
5	2.5	0	0	0	3.3	0	3.3	38	19	3.3	0	0	3.3	3.3	0
6	3	0	0	0	3.3	3.3	0	39	19.5	3.3	0	0	3.3	3.3	3.3
7	3.5	0	0	0	3.3	3.3	3.3	40	20	3.3	0	3.3	0	0	0
8	4	0	0	3.3	0	0	0	41	20.5	3.3	0	3.3	0	0	3.3
9	4.5	0	0	3.3	0	0	3.3	42	21	3.3	0	3.3	0	3.3	0
10	5	0	0	3.3	0	3.3	0	43	21.5	3.3	0	3.3	0	3.3	3.3
11	5.5	0	0	3.3	0	3.3	3.3	44	22	3.3	0	3.3	3.3	0	0
12	6	0	0	3.3	3.3	0	0	45	22.5	3.3	0	3.3	3.3	0	3.3
13	6.5	0	0	3.3	3.3	0	3.3	46	23	3.3	0	3.3	3.3	3.3	0
14	7	0	0	3.3	3.3	3.3	0	47	23.5	3.3	0	3.3	3.3	3.3	3.3
15	7.5	0	0	3.3	3.3	3.3	3.3	48	24	3.3	3.3	0	0	0	0
16	8	0	3.3	0	0	0	0	49	24.5	3.3	3.3	0	0	0	3.3
17	8.5	0	3.3	0	0	0	3.3	50	25	3.3	3.3	0	0	3.3	0
18	9	0	3.3	0	0	3.3	0	51	25.5	3.3	3.3	0	0	3.3	3.3
19	9.5	0	3.3	0	0	3.3	3.3	52	26	3.3	3.3	0	3.3	0	0
20	10	0	3.3	0	3.3	0	0	53	26.5	3.3	3.3	0	3.3	0	3.3
21	10.5	0	3.3	0	3.3	0	3.3	54	27	3.3	3.3	0	3.3	3.3	0
22	11	0	3.3	0	3.3	3.3	0	55	27.5	3.3	3.3	0	3.3	3.3	3.3
23	11.5	0	3.3	0	3.3	3.3	3.3	56	28	3.3	3.3	3.3	0	0	0
24	12	0	3.3	3.3	0	0	0	57	28.5	3.3	3.3	3.3	0	0	3.3
25	12.5	0	3.3	3.3	0	0	3.3	58	29	3.3	3.3	3.3	0	3.3	0
26	13	0	3.3	3.3	0	3.3	0	59	29.5	3.3	3.3	3.3	0	3.3	3.3
27	13.5	0	3.3	3.3	0	3.3	3.3	60	30	3.3	3.3	3.3	3.3	0	0
28	14	0	3.3	3.3	3.3	0	0	61	30.5	3.3	3.3	3.3	3.3	0	3.3
29	14.5	0	3.3	3.3	3.3	0	3.3	62	31	3.3	3.3	3.3	3.3	3.3	0
30	15	0	3.3	3.3	3.3	3.3	0	63	31.5	3.3	3.3	3.3	3.3	3.3	3.3
31	15.5	0	3.3	3.3	3.3	3.3	3.3								
32	16	3.3	0	0	0	0	0								

Note

Recommended ESD management

Refer to the application note AN0020 available at <http://www.ums-gaas.com> for ESD sensitivity and handling recommendations for the UMS products.

Ordering Information

Chip form: CHT4012-98F/00

Information furnished is believed to be accurate and reliable. However **United Monolithic Semiconductors S.A.S.** assumes no responsibility for the consequences of use of such information nor for any infringement of patents or other rights of third parties which may result from its use. No license is granted by implication or otherwise under any patent or patent rights of **United Monolithic Semiconductors S.A.S.**. Specifications mentioned in this publication are subject to change without notice. This publication supersedes and replaces all information previously supplied. **United Monolithic Semiconductors S.A.S.** products are not authorised for use as critical components in life support devices or systems without express written approval from **United Monolithic Semiconductors S.A.S.**