



Ultra Small 3-axis Magnetic Sensor, With I²C Interface

MMC328xMA

FEATURES

- Full integration of 3-axis magnetic sensors and electronics circuits resulting in less external components needed
- Flexible output resolution available, up to 14bits
- Small Low profile package 2.0x2.0x1.2mm
- Low power consumption
- Power up/down function available through I²C interface
- With continuous operation mode, frequency selectable
- I²C Slave, FAST (≤ 400 KHz) mode
- 1.8V compatible IO
- 1.62V~3.6V wide power supply operation supported, 1.8V typical operation.
- RoHS compliant

APPLICATIONS :

Electronic Compass
GPS Navigation
Position Sensing
Magnetometry

DESCRIPTIONS :

The MMC328xMA is a 3-axis magnetic sensor, it is a complete sensing system with on-chip signal processing and integrated I²C bus, allowing the device to be connected directly to a microprocessor eliminating the need for A/D converters or timing resources. It can measure magnetic field with a full range of ± 8 gauss.

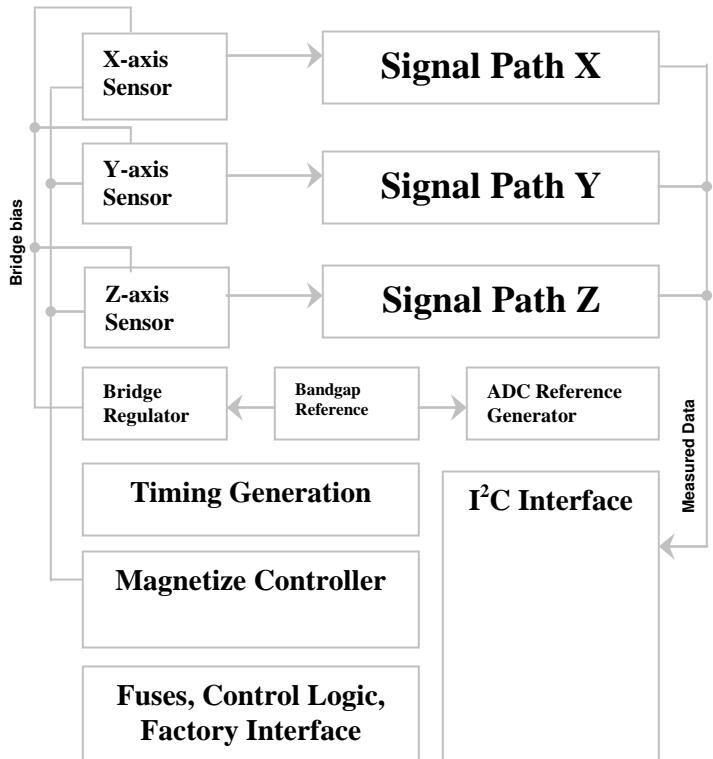

FUNCTIONAL BLOCK DIAGRAM

The MMC328xMA is packaged in an ultra small low profile BGA package (2.0 x 2.0 x 1.2 mm, including the 0.2mm height solder ball) and is available in operating temperature ranges of -40°C to +85°C.

The MMC328xMA provides an I²C digital output with 400 KHz, fast mode operation.

Information furnished by MEMSIC is believed to be accurate and reliable. However, no responsibility is assumed by MEMSIC for its use, or for any infringements of patents or other rights of third parties which may result from its use. No license is granted by implication or otherwise under any patent or patent rights of MEMSIC.

©MEMSIC, Inc.
One Technology Drive, Suite 325, Andover, MA01810, USA
Tel: +1 978 738 0900 Fax: +1 978 738 0196
www.memsic.com

SPECIFICATION: (Measurements @ 25°C, unless otherwise noted; $V_{DA} = V_{DD} = 1.8V$ unless otherwise specified)

Parameter	Conditions	Min	Typ	Max	Units
Field Range (Each Axis)	Total applied field		±8		gauss
Supply Voltage	V_{DA}	1.62 ¹	1.8	3.6	V
	V_{DD} (I ² C interface)	1.62 ¹	1.8	3.6	V
Supply Current	50 measurements/second	0.4	0.7	1.2	mA
Power Down Current		0.01		1.0	µA
Operating Temperature		-40		85	°C
Storage Temperature		-55		125	°C
Linearity Error (Best fit straight line)	±1 gauss		0.1		%FS
	±4 gauss		1.0		%FS
	+4~+8gauss		5.0		%FS
	-4~-8gauss				%FS
Hysteresis	3 sweeps across ±4 gauss		0.1		%FS
	3 sweeps across ±8 gauss		0.5		%FS
Repeatability Error	3 sweeps across ±4 gauss		0.1		%FS
	3 sweeps across ±8 gauss		0.5		%FS
Alignment Error			±1.0	±3.0	degrees
Transverse Sensitivity			±2.0	±5.0	%
Total RMS Noise ²	1~25Hz, RMS		1.0		mgauss
Bandwidth			25		Hz
Sensitivity	±4 gauss	-10		+10	%
	±8 gauss	-20		+20	%
	±4 gauss	461	512	563	counts/gauss
	±8 gauss	410	512	624	counts/gauss
Sensitivity Change Over Temperature	-40~85°C ±8 gauss		±1100		ppm/°C
Null Field Output	±8 gauss	-0.2		+0.2	gauss
		3994	4096	4198	counts
Null Field Output Change Over Temperature ³	Delta from 25°C ±8 gauss		±0.4		mgauss/°C
Disturbing Field		15			gauss
Maximum Exposed Field				10000	gauss

Note: ¹: 1.62V is the minimum operation voltage, or V_{DA} / V_{DD} should not be lower than 1.62V.

²: At this noise level, the typical heading error contribution is 0.8degree, and maximum is 2degree.

³: It can be significantly improved when using MEMSIC's proprietary software or algorithm.

I²C INTERFACE I/O CHARACTERISTICS (V_{DD}=1.8V)

Parameter	Symbol	Test Condition	Min.	Typ.	Max.	Unit
Logic Input Low Level	V _{IL}		-0.5		0.3* V _{DD}	V
Logic Input High Level	V _{IH}		0.7*V _{DD}		V _{DD}	V
Hysteresis of Schmitt input	V _{hys}		0.2			V
Logic Output Low Level	V _{OL}				0.4	V
Input Leakage Current	I _i	0.1V _{DD} <V _{in} <0.9V _{DD}	-10		10	μA
SCL Clock Frequency	f _{SCL}		0		400	kHz
START Hold Time	t _{HD,STA}		0.6			μS
START Setup Time	t _{SU,STA}		0.6			μS
LOW period of SCL	t _{LOW}		1.3			μS
HIGH period of SCL	t _{HIGH}		0.6			μS
Data Hold Time	t _{HD,DAT}		0		0.9	μS
Data Setup Time	t _{SU,DAT}		0.1			μS
Rise Time	t _r	From V _{IL} to V _{IH}			0.3	μS
Fall Time	t _f	From V _{IH} to V _{IL}			0.3	μS
Bus Free Time Between STOP and START	t _{BUF}		1.3			μS
STOP Setup Time	t _{SU,STO}		0.6			μS

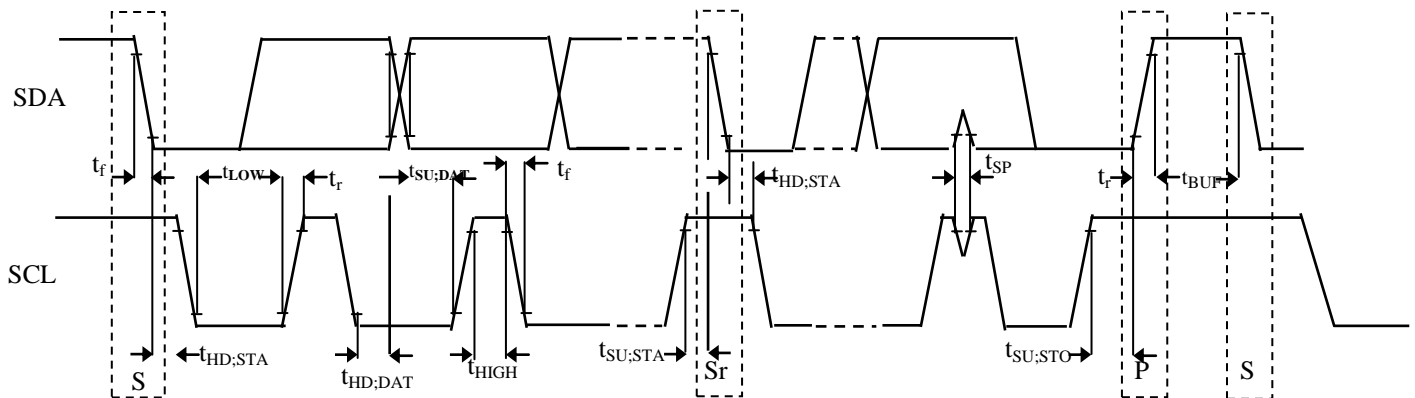

Timing Definition

ABSOLUTE MAXIMUM RATINGS*

Supply Voltage (V_{DD})-0.5 to +3.6V
 Storage Temperature-55°C to +125°C
 Maximum Exposed Field10000 gauss

*Stresses above those listed under Absolute Maximum Ratings may cause permanent damage to the device. This is a stress rating only; the functional operation of the device at these or any other conditions above those indicated in the operational sections of this specification is not implied. Exposure to absolute maximum rating conditions for extended periods may affect device reliability.

Pin Description: BGA Package

Pin	Name	Description	I/O
A1	CAP	Connect to External Capacitor	I
A3	SCL	Serial Clock Line for I ² C bus	I
A4	TEST	Factory Use Only, Leave Open/No Connect	NC
B1	V _{DA}	Power Supply	P
B3	SDA	Serial Data Line for I ² C bus	I/O
C1	VSA	Connect to Ground	P
C2	V _{pp}	Factory Use Only, Leave Open	NC
C4	V _{DD}	Power Supply for I ² C bus	P
D1	NC	No Connection	NC
D4	SDA	Serial Data Line for I ² C bus, internally shorted to B3	I/O

All parts are shipped in tape and reel packaging with 9000pcs per 13"reel or 3000pcs per 7" reel.

Caution: ESD (electrostatic discharge) sensitive device.

Ordering Guide:
 MMC328xMA

Package type:

Code	Type
A	pin-to-pin compatible package RoHS compliant

Performance Grade:

Code	Performance Grade
M	Temp compensated

Address code: 0~7

Code	7bit I ² C Address
0	0110000b
1	0110001b
2	0110010b
3	0110011b
4	0110100b
5	0110101b
6	0110110b
7	0110111b

Marking illustration:

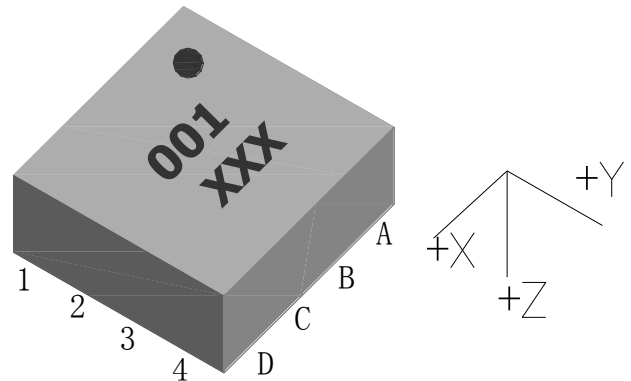

Number 0x	Part number
00	MMC3280MA
01	MMC3281MA
02	MMC3282MA
03	MMC3283MA
04	MMC3284MA
05	MMC3285MA
06	MMC3286MA
07	MMC3287MA

“Number” means the 1st two digits of the 1st line in the marking. The 3rd digit in the 1st line represents Year Code (1 stands for 2011), the 2nd line represents Lot Number. Small circle indicates pin one (1).

THEORY:

The anisotropic magnetoresistive (AMR) sensors are special resistors made of permalloy thin film deposited on a silicon wafer. During manufacturing, a strong magnetic field is applied to the film to orient its magnetic domains in the same direction, establishing a magnetization vector. Subsequently, an external magnetic field applied perpendicularly to the sides of the film causes the magnetization to rotate and change angle. This in turn causes the film’s resistance to vary. The MEMSIC AMR sensor is included in a Wheatstone bridge, so that the change in resistance is detected as a change in differential voltage and the strength of the applied magnetic field may be inferred.

However, the influence of a strong magnetic field (more than 15 gauss) along the magnetization axis could upset, or flip, the polarity of the film, thus changing the sensor characteristics. The MEMSIC magnetic sensor can provide an electrically-generated strong magnetic field to restore the sensor characteristics.

PIN DESCRIPTIONS:

V_{DA} – This is the supply input for the circuits and the magnetic sensor. The DC voltage should be between 1.62 and 3.6 volts. A 1uF by-pass capacitor is strongly recommended.

V_{SA} – This is the ground pin for the magnetic sensor.

SDA – This pin is the I²C serial data line, and operates in FAST (400 KHz) mode. Two SDA PADs internally shorted together.

SCL– This pin is the I²C serial clock line, and operates in FAST (400 KHz) mode.

V_{DD} – This is the power supply input for the I²C bus, and is 1.8V compatible can be 1.62V to 3.6V.

TEST – Factory use only, Leave Open/No Connect.

CAP –Connect a 10uF low ESR ceramic capacitor.

V_{pp} – Factory use only, Leave Open

EXTERNAL CAPACITOR CONNECTION

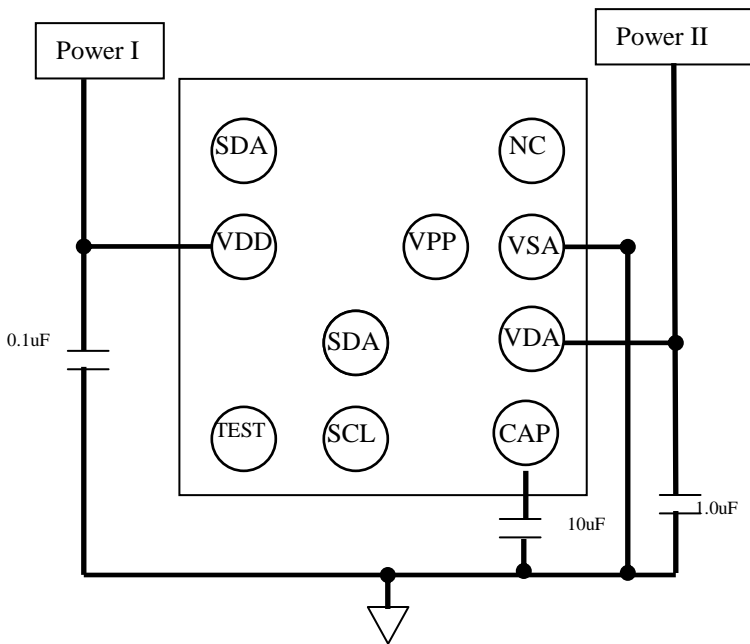

(Top View)

POWER CONSUMPTION

The MEMSIC magnetic sensor consumes 0.7mA (typical) current at 1.8V with 50 measurements/second, but the current is proportional to the number of measurements carried out, for example, if only 20 measurements/second are performed, the current will be $0.7 \cdot 20 / 50 = 0.28\text{mA}$.

I²C INTERFACE DESCRIPTION

A slave mode I²C circuit has been implemented into the MEMSIC magnetic sensor as a standard interface for customer applications. The A/D converter and MCU functionality have been added to the MEMSIC sensor, thereby increasing ease-of-use, and lowering power consumption, footprint and total solution cost.

The I²C (or Inter IC bus) is an industry standard bi-directional two-wire interface bus. A master I²C device can operate READ/WRITE controls to an unlimited number of devices by device addressing. The MEMSIC magnetic sensor operates only in a slave mode, i.e. only responding to calls by a master device.

I²C BUS CHARACTERISTICS

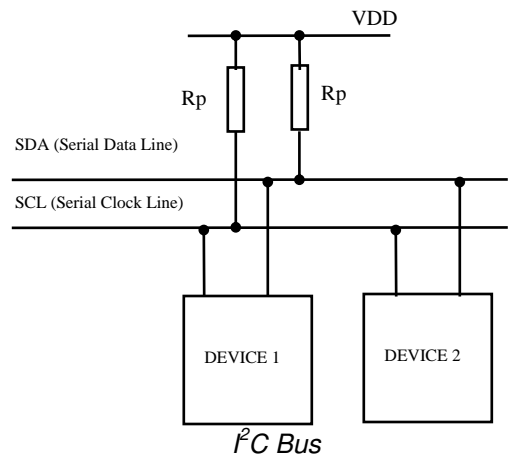

The two wires in I²C bus are called SDA (serial data line) and SCL (serial clock line). In order for a data transfer to start, the bus has to be free, which is defined by both wires in a HIGH output state. Due to the open-drain/pull-up resistor structure and wired Boolean “AND” operation, any device on the bus can pull lines low and overwrite a HIGH signal. The data on the SDA line has to be stable during the HIGH period of the SCL line. In other words, valid data can only change when the SCL line is LOW.

Note: Rp selection guide: 4.7Kohm for a short I²C bus length (less than 4inches), and 10Kohm for less than 2inches I²C bus.

REGISTER:

Register Name	Address	Description
Xout Low	00H	Xout LSB
Xout High	01H	Xout MSB
Yout Low	02H	Yout LSB
Yout High	03H	Yout MSB
Zout Low	04H	Zout LSB
Zout High	05H	Zout MSB
Status	06H	Device status
Internal control 0	07H	Control register 0
Internal control 1	08H	Control register 1
Product ID 0	10H	Product ID
R0	1CH	Factory used register
R1	1DH	Factory used register
R2	1EH	Factory used register
R3	1FH	Factory used register
Product ID 1	20H	Product ID

Register Details:

Xout High, Xout Low

Xout Low	7	6	5	4	3	2	1	0
Addr: 00H	Xout[7:0]							
Reset Value	Xout[7:0]							
Mode	R							

Xout High	7	6	5	4	3	2	1	0
Addr: 01H	Reserved		Xout[13:8]					
Reset Value	2'h0		Xout[13:8]					
Mode	R							

11 to 14bits X-axis output, unsigned format.

Yout High, Yout Low

Yout Low	7	6	5	4	3	2	1	0
Addr: 02H	Yout[7:0]							
Reset Value	Yout[7:0]							
Mode	R							

Yout High	7	6	5	4	3	2	1	0
Addr: 03H	Reserved		Yout[13:8]					
Reset Value	2'h0		Yout[13:8]					
Mode	R							

11 to 14bits Y-axis output, unsigned format.

Zout High, Zout Low

Zout Low	7	6	5	4	3	2	1	0
Addr: 04H	Zout[7:0]							
Reset Value	Zout[7:0]							
Mode	R							

Zout High	7	6	5	4	3	2	1	0
Addr: 05H	Reserved		Zout[13:8]					
Reset Value	2'h0		Zout[13:8]					
Mode	R							

11 to 14bits Z-axis output, unsigned format.

Status:

Device Status	7	6	5	4	3	2	1	0
Addr: 06H	Reserved					NVM_Rd Done	Pump On	Meas Done
Reset Value	5'h0					0	0	0
Mode	R							

Register Name	Description
Meas Done	Indicates measurement event is completed, should be checked before reading output
Pump On	Indicates the charge pump status
NVW_Rd Done	Indicates the chip was able to successfully read its NVW memory.

Internal Control 0:

Control Register 0	7	6	5	4	3	2	1	0
Addr: 07H	reserved	RRM	RM	No Boost	CM Freq1	CM Freq0	Cont Mode On	TM
Reset Value	0	0	0	0	0	0	0	0
Mode	W	W	W	W	W	W	W	W

Register Name	Description
TM	Take measurement, set '1' will initiate measurement.
Cont Mode On	Factory-use Register
CM Freq0	Factory-use Register
CM Freq1	
No Boost	Factory-use Register, fixed to "0"
RRM	Set "1" will result in the 1 st magnetization to the MR.
RM	Set "1" will result in a 2 nd magnetization to the MR.

Internal Control 1:

Control Register 1	7	6	5	4	3	2	1	0
Addr: 08H	Reserved		Filt Time Sel1	Filt Time Sel0	Res Sel1	Res Sel0	FSR1	FSR0
Reset Value	2'h0		0	0	0	0	0	0
Mode	W	W	W	W	W	W	W	W

Register Name	Description
FSR0	Factory-use Register
FSR1	
Res Sel0	Factory-use Register
Res Sel1	
Filt Time Sel0	Factory-use Register
Filt Time Sel1	

R0, R1, R2, R3, R4, R5

R0	7	6	5	4	3	2	1	0
Addr: 1CH	Factory-use Register							
Reset Value	Factory-use Register							
Mode	R							

R1	7	6	5	4	3	2	1	0
Addr: 1DH	Factory-use Register							
Reset Value	Factory-use Register							
Mode	R							

R2	7	6	5	4	3	2	1	0
Addr: 1EH	Factory-use Register							
Reset Value	Factory-use Register							
Mode	R							

R3	7	6	5	4	3	2	1	0
Addr: 1FH	Factory-use Register							
Reset Value	Factory-use Register							
Mode	R							

Product ID 0:

Product ID 0	7	6	5	4	3	2	1	0
Addr: 10H	Product ID0[2:0]			Factory-use Register				
Reset Value	X	X	X	Factory-use Register				
Mode	R	R	R	R	R	R	R	R

XXX: I²C address code.

Product ID 1:

Product ID 1	7	6	5	4	3	2	1	0
Addr: 20H	Product ID 1[7:0]							
Reset Value	0	0	0	0	0	0	0	0
Mode	R	R	R	R	R	R	R	R

DATA TRANSFER

A data transfer is started with a “START” condition and ended with a “STOP” condition. A “START” condition is defined by a HIGH to LOW transition on the SDA line while SCL line is HIGH. A “STOP” condition is defined by a LOW to HIGH transition on the SDA line while SCL line is HIGH. All data transfer in I²C system is 8-bits long. Each byte has to be followed by an acknowledge bit. Each data transfer involves a total of 9 clock cycles. Data is transferred starting with the most significant bit (MSB). After a “START” condition, master device calls specific slave device, in our case, a MEMSIC device with a 7-bit device address “[0110xxx]”. To avoid potential address conflict, either by ICs from other manufacturers or by other MEMSIC device on the same bus, a total of **8 different addresses** can be pre-programmed into MEMSIC device by the factory. Following the 7-bit address, the 8th bit determines the direction of data transfer: [1] for READ and [0] for WRITE. After being addressed, available MEMSIC device being called should respond by an “Acknowledge” signal, which is pulling SDA line LOW.

In order to read sensor signal, master device should operate a WRITE action with a code of [xxxxxxx1] into MEMSIC device 8-bit internal register. Note that this action also serves as a “wake-up” call.

After writing code of [xxxxxxx1] into Internal Control 0, and the bit0 TM (Status Register, bit 0) is ‘1’, also a “READ” command is received, the MEMSIC device being called transfers 8-bit data to I²C bus.

POWER STATE

MEMSIC MR sensor will enter power down mode automatically after data acquisition is finished.

VDA	VDD	Power State
OFF(0V)	OFF(0V)	OFF(0V), no power consumption
OFF(0V)	1.62~3.6V	OFF(0V), power consumption is less than 1uA.
1.62~3.6V	OFF(0V)	Power consumption is not predictable, not recommended state.
1.62~3.6V	1.62~3.6V	Normal operation mode, device will enter into power down mode automatically after data acquisition is finished

EXAMPLE OF TAKE MEASUREMENT

First cycle: START followed by a calling to slave address [0110xxx] to WRITE (8th SCL, SDA keep low). [xxx] is determined by factory programming, total 8 different addresses are available.

Second cycle: After an acknowledge signal is received by master device (MEMSIC device pulls SDA line low during 9th SCL pulse), master device sends “[00000111]” as the target address to be written into. MEMSIC device should acknowledge at the end (9th SCL pulse).

Third cycle: Master device writes to Internal Control Register 0 the code “[00000001]” as a wake-up call to initiate a data acquisition. MEMSIC device should send acknowledge.

A STOP command indicates the end of write operation.

Fourth cycle: Master device sends a START command followed by calling MEMSIC device address with a WRITE (8th SCL, SDA keep low). An acknowledge should be send by MEMSIC device at the end.

Fifth cycle: Master device writes to MEMSIC device a “[00000110]” as the address to read.

Sixth cycle: Master device calls MEMSIC device address with a READ (8th SCL cycle SDA line high). MEMSIC device should acknowledge at the end.

Seventh cycle: Master device cycles SCL line, the Status Register data appears on SDA line. Continuous read till Meas Done bit was set to ‘1’.

Eighth cycle: Master device sends a START command followed by calling MEMSIC device address with a WRITE (8th SCL, SDA keep low). An acknowledge should be send by MEMSIC device at the end.

Ninth cycle: Master device writes to MEMSIC device a “[00000000]” as the address to read.

Tenth cycle: Master device calls MEMSIC device address with a READ (8th SCL cycle SDA line high). MEMSIC device should acknowledge at the end.

Eleventh cycle: Master device continues to cycle the SCL line, next byte of internal memory should appear on SDA line (LSB of X channel). The internal memory address pointer automatically moves to the next byte. Master acknowledges.

Twelfth cycle: MSB of X channel.

Thirteenth cycle: LSB of Y channel.

Fourteenth cycle: MSB of Y channel.

Fifteenth cycle: LSB of Z channel.

Sixteenth cycle: MSB of Z channel.

Master ends communications by NOT sending 'Acknowledge' and also followed by a 'STOP' command.

EXAMPLE OF MAGNETIZATION

First cycle: START followed by a calling to slave address [0110xxx] to WRITE (8th SCL, SDA keep low). [xxx] is determined by factory programming, total 8 different addresses are available.

Second cycle: After an acknowledge signal is received by master device (MEMSIC device pulls SDA line low during 9th SCL pulse), master device sends "[00000111]" as the target address (Internal Control Register 0). MEMSIC device should acknowledge at the end (9th SCL pulse).

Third cycle: Master device writes to internal MEMSIC device memory the code "[01000000]" as a wake-up call to initiate a magnetization action. MEMSIC device should send acknowledge.

A minimum of 100uS wait should be given to MEMSIC device to finish magnetization action.

Forth cycle: Master device writes to internal MEMSIC device memory the code "[00000001]" to prepare for 2nd magnetization action.

A minimum of 50ms wait should be given to MEMSIC device to finish the preparation for 2nd magnetization action.

Fifth cycle: Master device writes to internal MEMSIC device memory the code "[00100000]" as a wake-up call to initiate a 2nd magnetization action. MEMSIC device should send acknowledge.

A minimum of 100mS wait should be given to MEMSIC device to finish magnetization action before taking a measurement.

Sixth cycle: Master device writes to internal MEMSIC device memory the code "[00000001]" to start a take measurement.

OPERATING TIMING

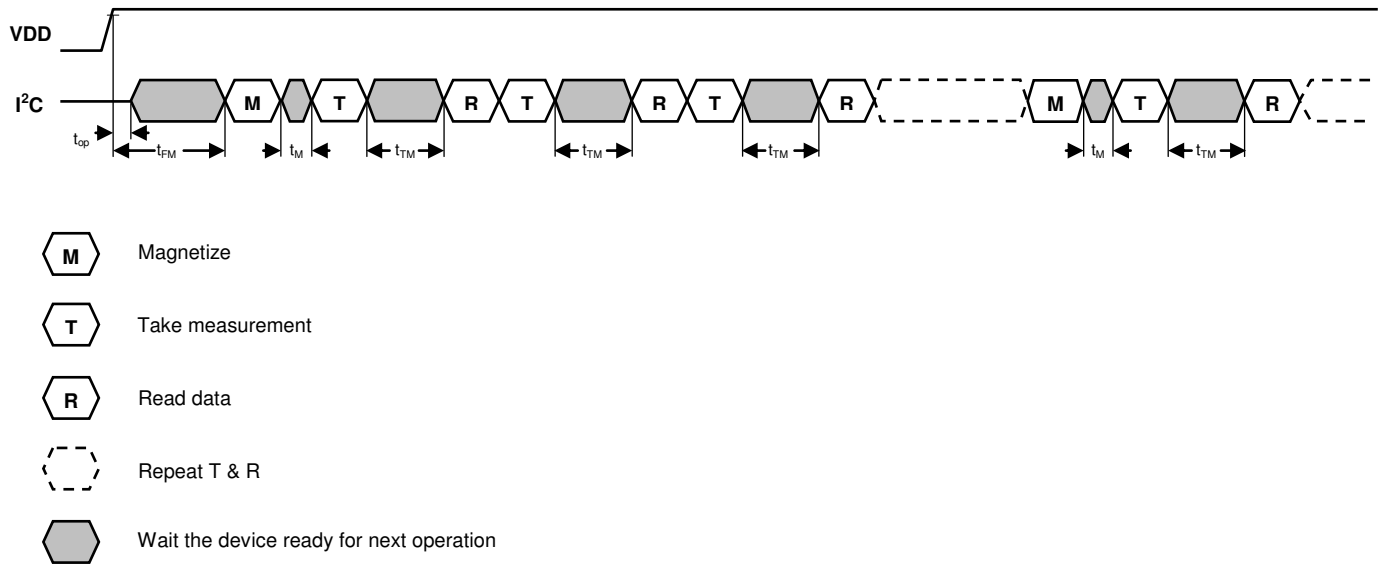

Operating Timing Diagram

Parameter	Symbol	Min.	Typ.	Max.	Unit
Time to operate device after Vdd valid	t_{op}	20			μ S
Wait time from power on to RM/RRM command	t_{FM}	10			mS
Time to finish 1 st magnetization	t_{M1}	50			mS
Time to finish 2 nd magnetization	t_{M2}	100			mS
Time to measure magnetic field	t_{TM}	7			mS

STORAGE CONDITIONS

Temperature: <30°C
Humidity: <60%RH
Period: 1 year (after delivery)

Moisture Sensitivity Level: 3

Bake Prior to Reflow: storage period more than 1 year, or humidity indicator card reads >60% at 23±5°C

Bake Procedure: refer to J-STD-033

Bake to Soldering: <1 week under 30°C/60%RH condition

SOLDERING RECOMMENDATIONS

MEMSIC magnetic sensor is capable of withstanding an MSL3 / 260°C solder reflow. Following is the reflow profile:

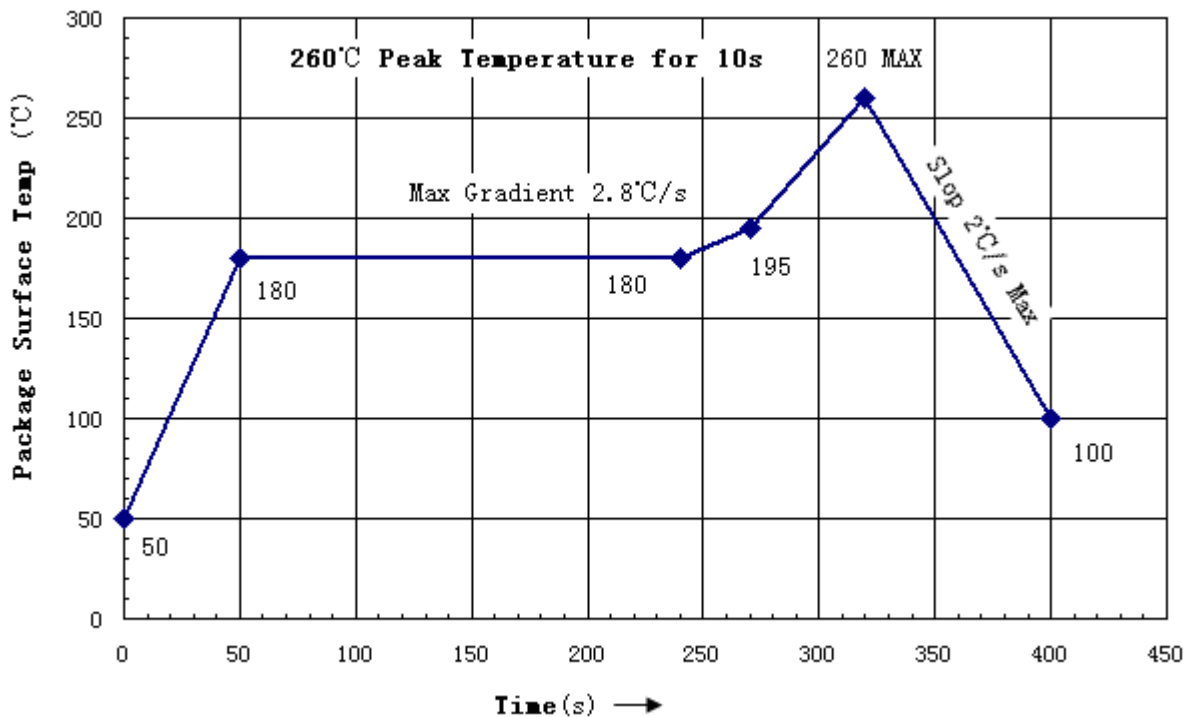

Note:

- Reflow is limited by 2 times
- The second reflow cycle should be applied after device has cooled down to 25°C (room temperature)
- This is the reflow profile for Pb free process
- The peak temperature on the sensor surface should be limited under 260°C for 10 seconds.
- Solder paste's reflow recommendation can be followed to get the best SMT quality.

If the part is mounted manually, please ensure the temperature could not exceed 260°C for 10 seconds.

PACKAGE DRAWING (BGA package)

(TOP VIEW)

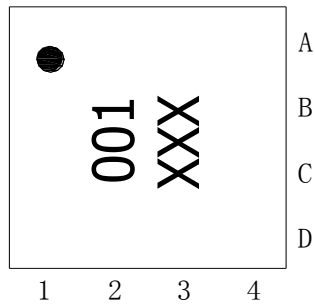

(BOTTOM VIEW)

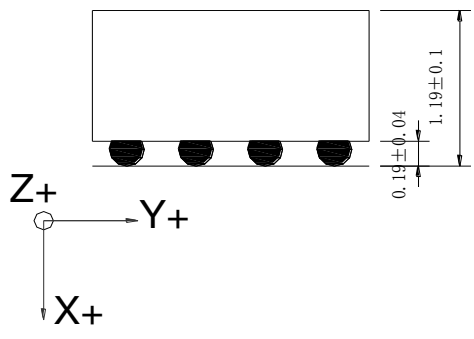
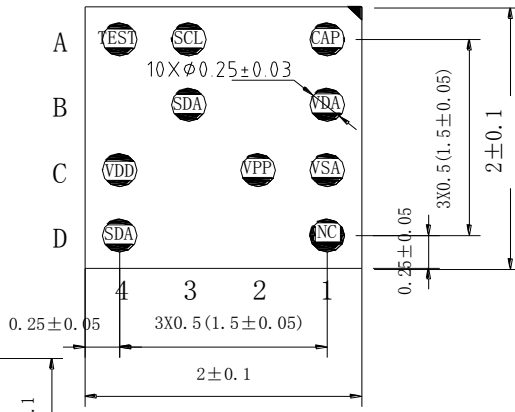

LAND PATTERN

Top view

