



±16 Gauss 3-axis Magnetic Sensor, With I²C Interface

MMC3316xMT

FEATURES

- Fully integrated 3-axis magnetic sensor and electronic circuits requiring fewer external components
- Superior Dynamic Range and Accuracy:
 - ✓ ±16G FSR with 14bit operation
 - ✓ 2 mG/LSB Resolution
 - ✓ 2 mG RMS noise
 - ✓ Enables heading accuracy <1°
- Small, Low profile package
2.0x2.0x1.0mm
- SET/RESET function clears the sensors of residual magnetization resulting from strong external fields
- Low power consumption (100µA @ 7 Hz)
- 1µA (max) power down function
- I²C Slave, FAST (≤400 KHz) mode
- 1.62V~3.6V wide power supply operation supported, 1.8V I/O compatibility.
- RoHS compliant

APPLICATIONS :

Electronic Compass & GPS Navigation
Position Sensing

DESCRIPTION:

The MMC3316xMT is a complete 3-axis magnetic sensor with on-chip signal processing and integrated I²C bus. The device can be connected directly to a microprocessor, eliminating the need for A/D converters or timing resources. It can measure magnetic fields within the full scale range of ±16 gauss, with 2 mG/LSB resolution and 2mG rms noise, enabling heading accuracies of <1 degree in electronic compass applications. Contact Memsic for access to advanced calibration and tilt-compensation algorithms.

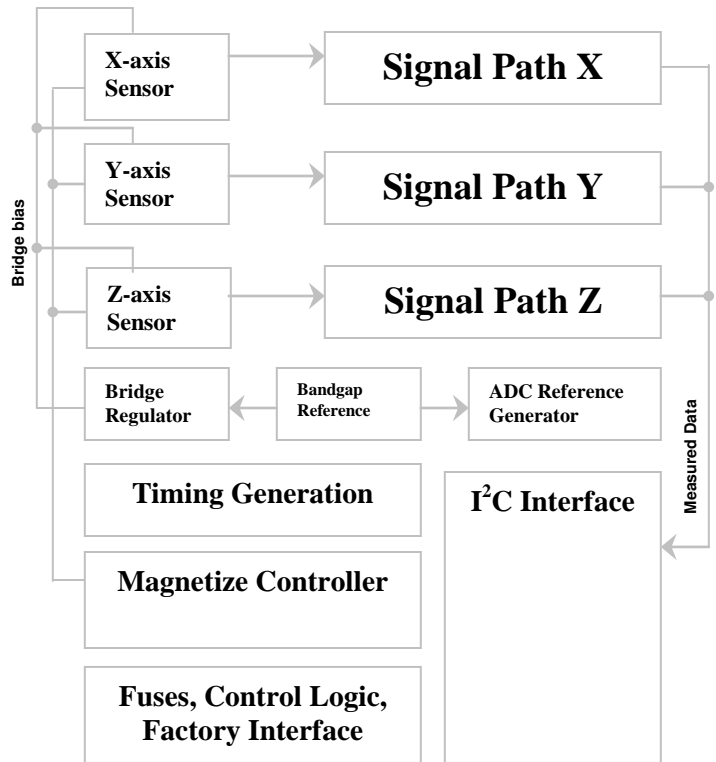

FUNCTIONAL BLOCK DIAGRAM

In addition, an integrated SET/RESET function enables the sensors to be “cleared” of any residual magnetic polarization resulting from exposure to strong external magnets. The SET/RESET function can be performed prior to each measurement, or periodically if desired, to maintain a stable sensor offset over time.

The MMC3316xMT is packaged in a small low profile LGA package (2.0 x 2.0 x 1.0 mm,) and with an operating temperature rang from -40°C to +85°C.

The MMC3316xMT provides an I²C digital output with 400 KHz, fast mode operation.

Information furnished by MEMSIC is believed to be accurate and reliable. However, no responsibility is assumed by MEMSIC for its use, or for any infringements of patents or other rights of third parties which may result from its use. No license is granted by implication or otherwise under any patent or patent rights of MEMSIC.

SPECIFICATIONS: (Measurements @ 25°C, unless otherwise noted; $V_{DA} = V_{DD} = 1.8V$ unless otherwise specified)

Parameter	Conditions	Min	Typ	Max	Units
Field Range (Each Axis)	Total applied field		±16		gauss
Supply Voltage	V_{DA}	1.62 ¹	1.8	3.6	V
	V_{DD} (I ² C interface)	1.62 ¹	1.8	3.6	V
Supply Current ²	7 measurements/second	0.06	0.10	0.16	mA
Power Down Current		0.01		1.0	µA
Operating Temperature		-40		85	°C
Storage Temperature		-55		125	°C
Linearity Error (Best fit straight line)	±16 gauss		1.0		%FS
Hysteresis	3 sweeps across ±16 gauss		0.5		%FS
Repeatability Error	3 sweeps across ±16 gauss		0.5		%FS
Alignment Error			±1.0	±3.0	degrees
Transverse Sensitivity			±2.0	±5.0	%
Total RMS Noise	1~25Hz, RMS		2.0		mgauss
Output resolution			14		bits
Heading accuracy ³			±0.5	±1.0	degrees
Bandwidth			25		Hz
Sensitivity	±16 gauss	-10		+10	%
	±16 gauss	460	512	564	counts/gauss
Sensitivity Change Over Temperature	-40~85°C ±16 gauss		±1100		ppm/°C
Null Field Output		-0.2		+0.2	gauss
	±16 gauss	8090	8192	8294	counts
Null Field Output Change Over Temperature ⁴	Delta from 25°C ±16 gauss		±0.4		mgauss/°C
Disturbing Field		25			gauss
Maximum Exposed Field				10000	gauss

Note: 1: 1.62V is the minimum operation voltage, or V_{DA} / V_{DD} should not be lower than 1.62V.

2: Power consumption is proportional to how many measurements performed per second, for example, at one measurement per second, the power consumption will be $0.1mA/7=0.014mA$.

3: MEMSIC product is with low noise and enables users to utilize heading accuracy to be 0.5 degree typical and 1.0degree maximum when using MEMSIC's proprietary software or algorithm

4. The error can be eliminated by using SET and RESET to determine the true Null Field output for each measurement.

I²C INTERFACE I/O CHARACTERISTICS (V_{DD}=1.8V)

Parameter	Symbol	Test Condition	Min.	Typ.	Max.	Unit
Logic Input Low Level	V _{IL}		-0.5		0.3* V _{DD}	V
Logic Input High Level	V _{IH}		0.7*V _{DD}		V _{DD}	V
Hysteresis of Schmitt input	V _{hys}		0.2			V
Logic Output Low Level	V _{OL}				0.4	V
Input Leakage Current	I _i	0.1V _{DD} <V _{in} <0.9V _{DD}	-10		10	μA
SCL Clock Frequency	f _{SCL}		0		400	kHz
START Hold Time	t _{HD,STA}		0.6			μS
START Setup Time	t _{SU,STA}		0.6			μS
LOW period of SCL	t _{LOW}		1.3			μS
HIGH period of SCL	t _{HIGH}		0.6			μS
Data Hold Time	t _{HD,DAT}		0		0.9	μS
Data Setup Time	t _{SU,DAT}		0.1			μS
Rise Time	t _r	From V _{IL} to V _{IH}			0.3	μS
Fall Time	t _f	From V _{IH} to V _{IL}			0.3	μS
Bus Free Time Between STOP and START	t _{BUF}		1.3			μS
STOP Setup Time	t _{SU,STO}		0.6			μS

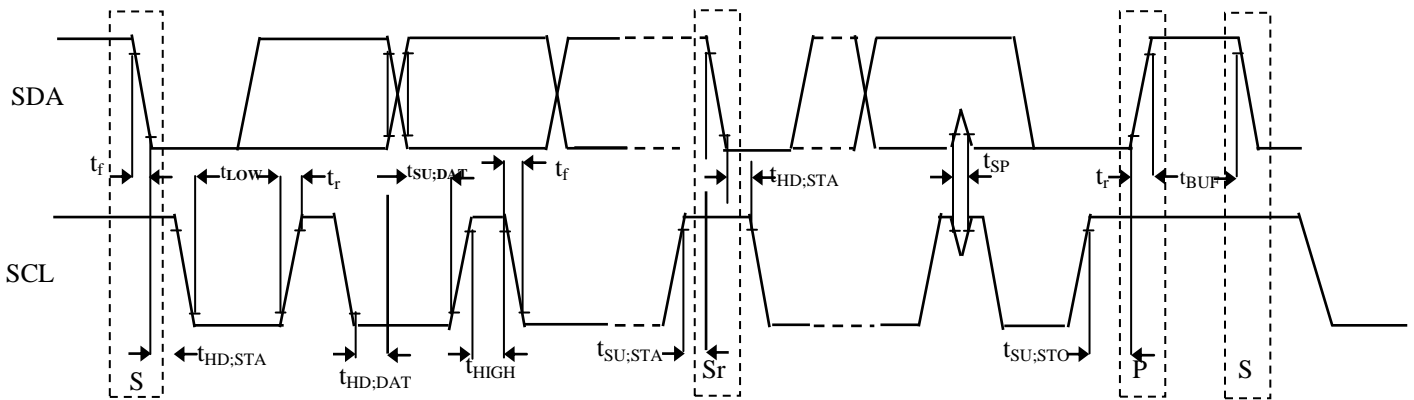

Timing Definition

ABSOLUTE MAXIMUM RATINGS*

Supply Voltage (V_{DD})-0.5 to +3.6V
 Storage Temperature-55°C to +125°C
 Maximum Exposed Field10000 gauss

*Stresses above those listed under Absolute Maximum Ratings may cause permanent damage to the device. This is a stress rating only; the functional operation of the device at these or any other conditions above those indicated in the operational sections of this specification is not implied. Exposure to absolute maximum rating conditions for extended periods may affect the device's reliability.

Pin Description: LGA Package

Pin	Name	Description	I/O
1	VDA	Power Supply	P
2	Vpp	Factory Use Only, Leave Open	NC
3	TEST	Factory Use Only, Leave Open/No Connection	NC
4	C+	Short together	I
5	C-		I
6	CAP	Connect to External Capacitor	I
7	SCL	Serial Clock Line for I2C bus	I
8	VDD	Power Supply for I2C bus	P
9	SDA	Serial Data Line for I2C bus	I/O
10	VSA	Connect to Ground	P

All parts are shipped in tape and reel packaging with 9000pcs per 13" reel or 3000pcs per 7" reel.

Caution: ESD (electrostatic discharge) sensitive device.

Ordering Guide:

MMC3316xMT

Package type:

Code	Type
T	LGA10 RoHS compliant

Performance Grade:

Code	Performance Grade
M	Temp compensated

Address code: 0~7

Code	7bit I ² C Address
0	0110000b
1	0110001b
2	0110010b
3	0110011b
4	0110100b
5	0110101b
6	0110110b
7	0110111b

Marking illustration:

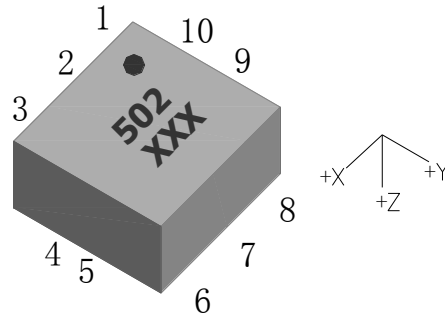

Number	Part number
5x	
50	MMC33160MT
51	MMC33161MT
52	MMC33162MT
53	MMC33163MT
54	MMC33164MT
55	MMC33165MT
56	MMC33166MT
57	MMC33167MT

“Number” means the 1st two digits of the 1st line in the marking. The 3rd digit in the 1st line represents Year Code (2 stands for 2012), the 2nd line represents Lot Number. Small circle indicates pin one (1).

THEORY:

The anisotropic magnetoresistive (AMR) sensors are special resistors made of permalloy thin film deposited on a silicon wafer. During manufacturing, a strong magnetic field is applied to the film to orient its magnetic domains in the same direction, establishing a magnetization vector. Subsequently, an external magnetic field applied perpendicularly to the sides of the film causes the magnetization to rotate and change angle. This in turn causes the film's resistance to vary. The MEMSIC AMR sensor is incorporated into a Wheatstone bridge, so that the change in resistance is detected as a change in differential voltage and the strength of the applied magnetic field may be inferred.

However, the influence of a strong magnetic field (more than 25 gauss) in any direction could upset, or flip, the polarity of the film, thus changing the sensor characteristics. A strong restoring magnetic field must be applied momentarily to restore, or set, the sensor characteristics. The MEMSIC magnetic sensor has an on-chip magnetically coupled strap: a SET/RESET strap pulsed with a high current, to provide the restoring magnetic field.

PIN DESCRIPTIONS:

V_{DA} – This is the supply input for the circuits and the magnetic sensor. The DC voltage should be between 1.62 and 3.6 volts. A 1uF by-pass capacitor is strongly recommended.

V_{SA} – This is the ground pin for the magnetic sensor.

SDA – This pin is the I²C serial data line, and operates in FAST (400 KHz) mode.

SCL – This pin is the I²C serial clock line, and operates in FAST (400 KHz) mode.

V_{DD} – This is the power supply input for the I²C bus, and is 1.8V compatible can be 1.62V to 3.6V.

TEST – Factory use only, Leave Open/No Connection.

CAP –Connect a 4.7uF low ESR (typically smaller than 0.2ohm) ceramic capacitor.

V_{pp} – Factory use only, Leave Open

C+, C- –Short together.

EXTERNAL CAPACITOR CONNECTION

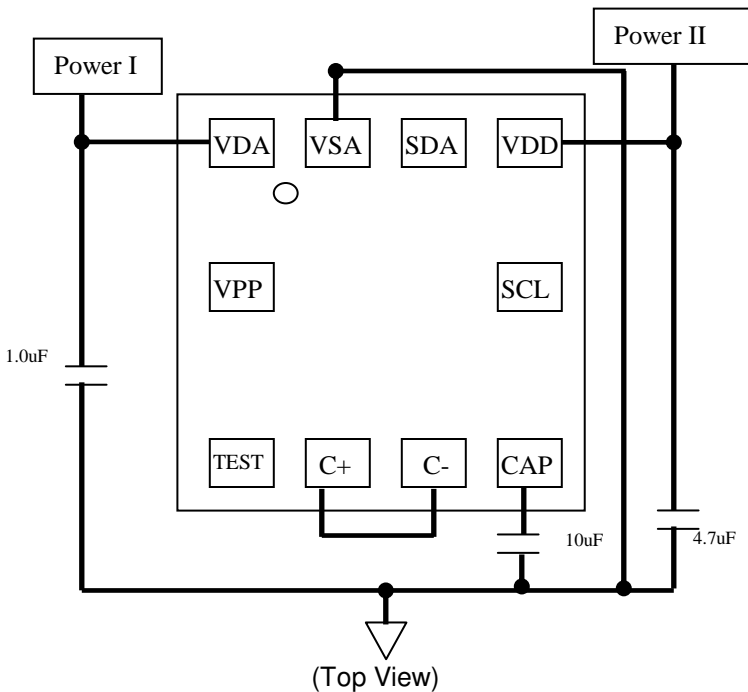

POWER CONSUMPTION

The MEMSIC magnetic sensor consumes 0.1mA (typical) at 1.8V with 7 measurements/second, but the current is proportional to the number of measurements carried out, for example, if only 2 measurements/second are performed, the current will be $0.1 * 2 / 7 = 0.028mA$.

I²C INTERFACE DESCRIPTION

A slave mode I²C circuit has been implemented into the MEMSIC magnetic sensor as a standard interface for customer applications. The A/D converter and MCU functionality have been added to the MEMSIC sensor, thereby increasing ease-of-use, and lowering power consumption, footprint and total solution cost.

The I²C (or Inter IC bus) is an industry standard bi-directional two-wire interface bus. A master I²C device can operate READ/WRITE controls to an unlimited number of devices by device addressing. The MEMSIC magnetic sensor operates only in a slave mode, i.e. only responding to calls by a master device.

I²C BUS CHARACTERISTICS

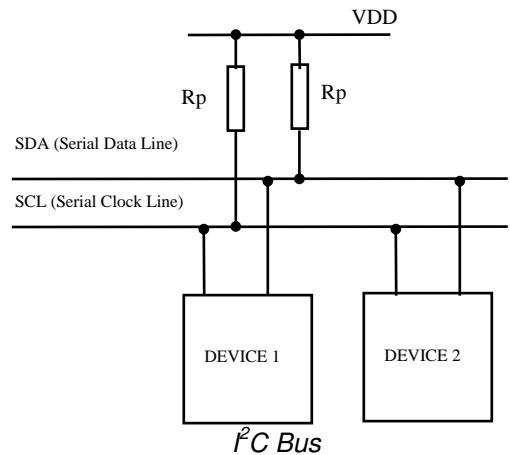

The two wires in the I²C bus are called SDA (serial data line) and SCL (serial clock line). In order for a data transfer to start, the bus has to be free, which is defined by both wires in a HIGH output state. Due to the open-drain/pull-up resistor structure and wired Boolean “AND” operation, any device on the bus can pull lines low and overwrite a HIGH signal. The data on the SDA line has to be stable during the HIGH period of the SCL line. In other words, valid data can only change when the SCL line is LOW.

Note: Rp selection guide: 4.7Kohm for a short I²C bus length (less than 4inches), and 10Kohm for a bus length less than 2inches.

REGISTER:

Register Name	Address	Description
Xout Low	00H	Xout LSB
Xout High	01H	Xout MSB
Yout Low	02H	Yout LSB
Yout High	03H	Yout MSB
Zout Low	04H	Zout LSB
Zout High	05H	Zout MSB
Status	06H	Device status
Internal control 0	07H	Control register 0
Internal control 1	08H	Control register 1
Product ID 0	10H	Product ID
R0	1CH	Factory used register
R1	1DH	Factory used register
R2	1EH	Factory used register
R3	1FH	Factory used register
Product ID 1	20H	Product ID

Register Details:

Xout High, Xout Low

Xout Low	7	6	5	4	3	2	1	0
Addr: 00H	Xout[7:0]							
Reset Value	Xout[7:0]							
Mode	R							

Xout High	7	6	5	4	3	2	1	0
Addr: 01H	Reserved		Xout[13:8]					
Reset Value	2'h0		Xout[13:8]					
Mode	R							

14bits X-axis output, unsigned format.

Yout High, Yout Low

Yout Low	7	6	5	4	3	2	1	0
Addr: 02H	Yout[7:0]							
Reset Value	Yout[7:0]							
Mode	R							

Yout High	7	6	5	4	3	2	1	0
Addr: 03H	Reserved		Yout[13:8]					
Reset Value	2'h0		Yout[13:8]					
Mode	R							

14bits Y-axis output, 2's unsigned format.

Zout High, Zout Low

Zout Low	7	6	5	4	3	2	1	0
Addr: 04H	Zout[7:0]							
Reset Value	Zout[7:0]							
Mode	R							

Zout High	7	6	5	4	3	2	1	0
Addr: 05H	Reserved		Zout[13:8]					
Reset Value	2'h0		Zout[13:8]					
Mode	R							

14bits Z-axis output, unsigned format.

Status:

Device Status	7	6	5	4	3	2	1	0
Addr: 06H	Reserved					NVM_Rd Done	Pump On	Meas Done
Reset Value	5'h0					0	0	0
Mode	R							

Bit Name	Description
Meas Done	Indicates measurement event is completed. This bit should be checked before reading the output
Pump On	Indicates the charge pump status
NVW_Rd Done	Indicates the chip was able to successfully read its memory.

Internal Control 0:

Control Register 0	7	6	5	4	3	2	1	0
Addr: 07H	reserved	RESET	SET	No Boost	CM Freq1	CM Freq0	Cont Mode On	TM
Reset Value	0	0	0	0	0	0	0	0
Mode	W	W	W	W	W	W	W	W

Bit Name	Description
TM	Take measurement, set '1' will initiate measurement.
Cont Mode On	Factory-use Register
CM Freq0	Factory-use Register
CM Freq1	
No Boost	Factory-use Register, fixed to "0"
RESET	Writing "1" will reset the MR by passing a large current through Set/Reset Coil at a reversed direction
SET	Writing "1" will set the MR by passing a large current through Set/Reset Coil

Internal Control 1:

Control Register 1	7	6	5	4	3	2	1	0
Addr: 08H	Reserved		Filt Time Sel1	Filt Time Sel0	Res Sel1	Res Sel0	FSR1	FSR0
Reset Value	2'h0		0	0	0	0	0	0
Mode	W	W	W	W	W	W	W	W

Bit Name	Description
FSR0	Factory-use Register
FSR1	
Res Sel0	Factory-use Register
Res Sel1	
Filt Time Sel0	Factory-use Register
Filt Time Sel1	

R0, R1, R2, R3

R0	7	6	5	4	3	2	1	0
Addr: 1CH	Factory-use Register							
Reset Value	Factory-use Register							
Mode	R							

R1	7	6	5	4	3	2	1	0
Addr: 1DH	Factory-use Register							
Reset Value	Factory-use Register							
Mode	R							

R2	7	6	5	4	3	2	1	0
Addr: 1EH	Factory-use Register							
Reset Value	Factory-use Register							
Mode	R							

R3	7	6	5	4	3	2	1	0
Addr: 1FH	Factory-use Register							
Reset Value	Factory-use Register							
Mode	R							

Product ID 0:

Product ID 0	7	6	5	4	3	2	1	0
Addr: 10H	Product ID0[2:0]			Factory-use Register				
Reset Value	X	X	X	Factory-use Register				
Mode	R	R	R	R	R	R	R	R

XXX: I²C address code.

Product ID 1:

Product ID 1	7	6	5	4	3	2	1	0
Addr: 20H	Product ID 1[7:0]							
Reset Value	0	0	0	0	0	1	0	1
Mode	R	R	R	R	R	R	R	R

DATA TRANSFER

A data transfer is started with a “START” condition and ended with a “STOP” condition. A “START” condition is defined by a HIGH to LOW transition on the SDA line while SCL line is HIGH. A “STOP” condition is defined by a LOW to HIGH transition on the SDA line while the SCL line is held HIGH. All data transfer in I²C system are 8-bits long. Each byte has to be followed by an acknowledge bit. Each data transfer involves a total of 9 clock cycles. Data is transferred starting with the most significant bit (MSB). After a “START” condition, the master device calls a specific slave device, in our case, a MEMSIC device with a 7-bit device address [0110xxx]. To avoid potential address conflicts, either by ICs from other manufacturers or by other MEMSIC devices on the same bus, a total of **8 different addresses** can be pre-programmed into MEMSIC device by the factory. Following the 7-bit address, the 8th bit determines the direction of data transfer: [1] for READ and [0] for WRITE. After being addressed, the MEMSIC device should respond with an “Acknowledge” signal, which pulls the SDA line LOW.

In order to read the sensor signal, a master device should initiate a WRITE action with a code of [xxxxxxx1] into the MEMSIC device’s 8-bit internal control register 0. Note that this action also serves as a “wake-up” call.

After writing the code [xxxxxxx1] into Internal Control 0, and the bit0 TM (Status Register, bit 0) is ‘1’, also a “READ” command is received, the MEMSIC device being called transfers 8-bit data to I²C bus.

POWER STATE

MEMSIC MR Sensor will enter power down mode automatically after data acquisition is finished.

VDA	VDD	Power State
OFF(0V)	OFF(0V)	OFF(0V), no power consumption
OFF(0V)	1.62~3.6V	OFF(0V), power consumption is less than 1uA.
1.62~3.6V	OFF(0V)	Power consumption is not predictable, not recommended state.
1.62~3.6V	1.62~3.6V	Normal operation mode, device will enter into power down mode automatically after data acquisition is finished

EXAMPLE MEASUREMENT

First cycle: A START condition is established by the Master Device followed by a call to the slave address [0110xxx] with the eighth bit held low to indicate a WRITE request. Note: [xxx] is determined by factory programming and a total of 8 different addresses are available.

Second cycle: After an acknowledge signal is received by master device (MEMSIC device pulls SDA line low during 9th SCL pulse), the master device sends the address of Control Register 0 or [00000111] as the target register to be written. The MEMSIC device should acknowledge at the end (9th SCL pulse, SCL pulled low).

Third cycle: The Master device writes to the Internal Control Register 0 the code [00000001] as a wake-up call to initiate a data acquisition. The MEMSIC device should send an Acknowledge.

A STOP condition indicates the end of the write operation.

Fourth cycle: The Master device sends a START command followed by the MEMSIC device’s seven bit address, and finally the eighth bit set low to indicate a WRITE. An Acknowledge should be send by the MEMSIC device in response.

Fifth cycle: The Master device sends the MEMSIC device’s Status Register [00000110] as the address to read.

Sixth cycle: The Master device sends a START command followed by the MEMSIC device’s seven bit address, and finally the eighth bit set high to indicate a READ. An Acknowledge should be send by the MEMSIC device in response.

Seventh cycle: The Master device cycles the SCL line. This causes the Status Register data to appear on SDA line. Continuously read the Status Register until the Meas Done bit is set to ‘1’.

Eighth cycle: The Master device sends a START command followed by the MEMSIC device’s seven bit address, and finally the eighth bit set low to indicate a WRITE. An Acknowledge should be send by the MEMSIC device in response.

Ninth cycle: The Master device sends a [00000000] (Xout LSB register address) as the register address to read.

Tenth cycle: The Master device calls the MEMSIC device’s address with a READ (8th SCL cycle SDA line high). An Acknowledge should be send by the MEMSIC device in response.

Eleventh cycle: Master device continues to cycle the SCL line, and each consecutive byte of data from the X, Y and Z registers should appear on the SDA line. The internal memory address pointer automatically moves to the next byte. The Master device acknowledges each. Thus:

Eleventh cycle: LSB of X channel.

Twelfth cycle: MSB of X channel.

Thirteenth cycle: LSB of Y channel.

Fourteenth cycle: MSB of Y channel.

Fifteenth cycle: LSB of Z channel.

Sixteenth cycle: MSB of Z channel.

Master ends communications by NOT sending an 'Acknowledge' and also follows with a 'STOP' command.

EXAMPLE OF SET/RESET

First cycle: A START condition is established by the Master Device followed by a call to the slave address [0110xxx] with the eighth bit held low to indicate a WRITE request. Note: [xxx] is determined by factory programming and a total of 8 different addresses are available.

Second cycle: After an acknowledge signal is received by the master device (The MEMSIC device pulls the SDA line low during the 9th SCL pulse), the master device sends [00000111] as the target address (Internal Control Register 0). The MEMSIC device should acknowledge at the end (9th SCL pulse).

Third cycle: The Master device writes to the MEMSIC device's Internal Control Register the code [00000001] to prepare for SET action.*

A minimum of 50ms wait should be provided to allow the MEMSIC device to finish its preparation for the SET action.*

Fourth cycle: The Master device writes to the MEMSIC device's Internal Control 0 register the code [00100000] as a wake-up call to initiate a SET action. MEMSIC device should send an Acknowledge.

Fifth cycle: The Master device writes to the MEMSIC device's Internal Control 0 register the code [00000000] to stop the SET action. MEMSIC device should send an Acknowledge.

A minimum of 50ms wait should be provided to allow the MEMSIC device to finish its preparation for RESET action.**

Sixth cycle: Master device writes to the MEMSIC device's Internal Control 0 register the code [01000000] as a wake-up call to initiate a RESET action. The MEMSIC device should send an Acknowledge.**

Seventh cycle: The Master device writes to the MEMSIC device's Internal Control 0 register the code [00000000] to stop the RESET action. MEMSIC device should send an Acknowledge.

A minimum of 50uS wait should be given to MEMSIC device to finish RESET action before taking a measurement.

Eighth cycle: Master device writes to internal MEMSIC device memory the code "[00000001]" to start a take measurement.

*Note *: The SET preparation action is only required when the part is inactive for a long time (typically >5seconds).*

*Note **: The RESET action can be skipped for most of the applications*

USING SET/RESET TO CALIBRATE NULL FIELD OUTPUT

The integrated SET and RESET functions of the MMC3316xMT enables the user to remove error associated with Offset change as a function of temperature, thereby enabling more precise heading measurements over a wider temperature than competitive technologies. The functions effectively flip the magnetic sensing polarity of the sensing elements of the device. In its simplest form the procedure and calculation are:

- 1) Perform SET/MEASURE (Output1 = H + Offset)
- 2) Perform RESET/MEASURE (Output2 = -H + Offset)
- 3) Calculate H by subtracting the two measurements and divide by 2

Where H is the applied magnetic field and Offset is the Null Field output. Time between the Set/Measure and RESET/Measure operation needs to be kept as short as possible to minimize error induced by the applied magnetic field changing between the two operations.

OPERATING TIMING

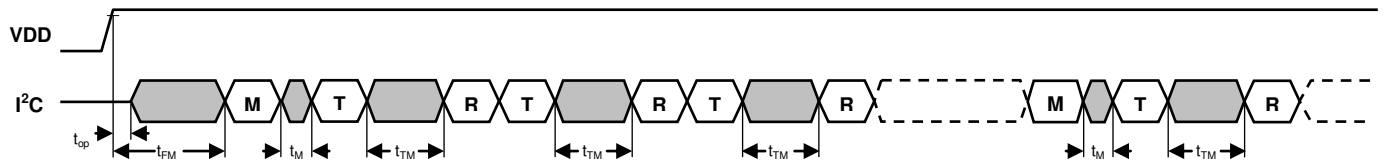

- Magnetize
- Take measurement
- Read data
- Repeat T & R
- Wait the device ready for next operation

Operating Timing Diagram

Parameter	Symbol	Min.	Typ.	Max.	Unit
Time to operate device after Vdd valid	t_{op}	20			μ S
Wait time from power on to RM/RRM command	t_{FM}	100			mS
Time to finish 1 st magnetization	t_{M1}	50			mS
Time to finish 2 nd magnetization	t_{M2}	50			mS
Time to measure magnetic field	t_{TM}	10			mS

STORAGE CONDITIONS

Temperature: <30°C
Humidity: <60%RH
Period: 1 year (after delivery)

Moisture Sensitivity Level: 3

Bake Prior to Reflow: storage period more than 1 year, or humidity indicator card reads >60% at 23±5°C

Bake Procedure: refer to J-STD-033

Bake to Soldering: <1 week under 30°C/60%RH condition

SOLDERING RECOMMENDATIONS

MEMSIC magnetic sensor is capable of withstanding an MSL3 / 260°C solder reflow. Following is the reflow profile:

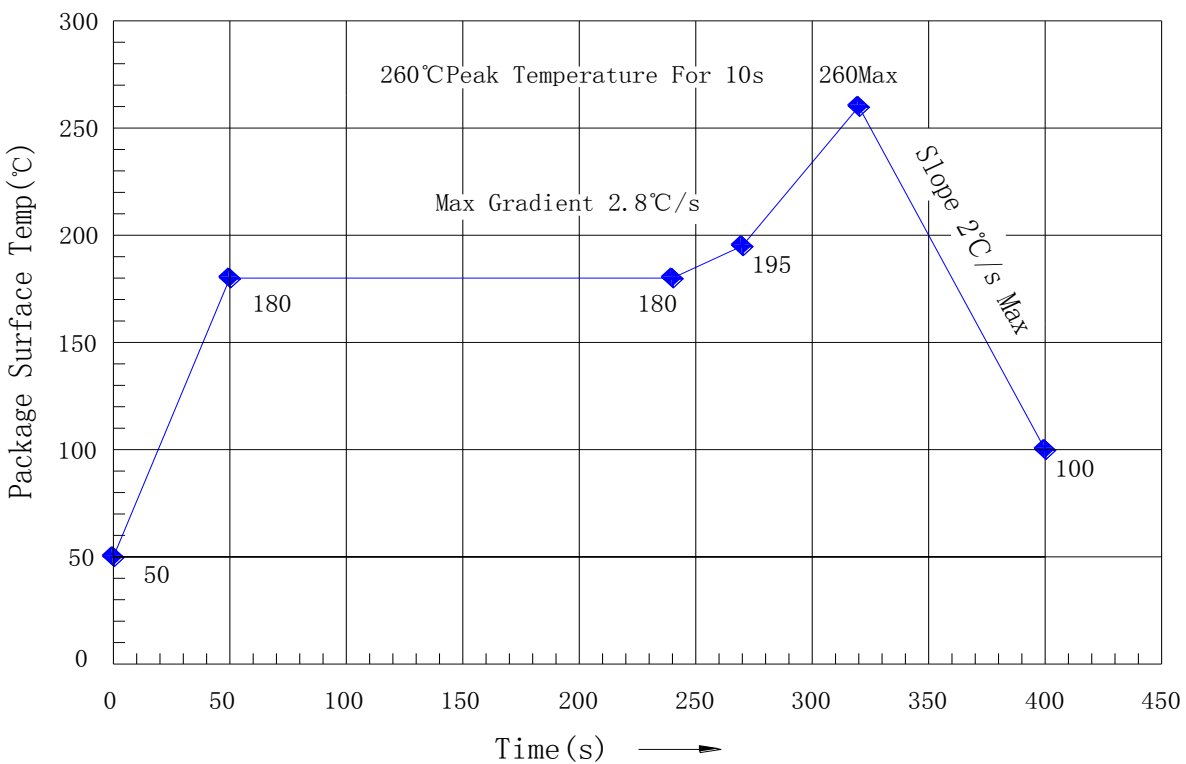

Note:

- Reflow is limited by 2 times
- The second reflow cycle should be applied after device has cooled down to 25°C (room temperature)
- This is the reflow profile for Pb free process
- The peak temperature on the sensor surface should be limited under 260°C for 10 seconds.
- Solder paste's reflow recommendation can be followed to get the best SMT quality.

If the part is mounted manually, please ensure the temperature could not exceed 260°C for 10 seconds.

PACKAGE DRAWING (LGA package)

