

66327 7.5 kV HIGH VOLTAGE, 4N55 TYPE HIGH SPEED ISOLATOR



09/18/2009

Features:

- TTL and CMOS compatible
- 7.5 kVdc Isolation
- 2 MHz Bandwidth typical
- Integral Detector Die Faraday Shield for improved Common Mode Rejection

Applications:

- High Voltage Isolation
- Voltage Level Shifting
- Isolated Receiver Input
- Switching power supplies
- Medical systems

DESCRIPTION

The **66327** high voltage isolator consists of an 850 nm LED optically coupled to a photodiode driven detector. The isolator provides high isolation and fast switching speeds over the specified temperature range of -40°C to +100°C. The isolator is built with hermetic components internally optically coupled and encased in a high temperature outer PPS plastic housing.

ABSOLUTE MAXIMUM RATINGS (T_A=25°C unless otherwise specified)

Isolation Voltage (Input to Output) (Note 2)	7.5 kVdc
Operating Free-Air Temperature Range	-40°C to +100°C
Storage Temperature	-40°C to +100°C
Lead Solder Temperature (10 second, 1.6 mm from case) (Note 1)	260°C

LED:

Peak Forward Input Current (2 μs duration)	300 mA
Average Forward Input Current	20 mA
Reverse Input Voltage	3.0 V
Input Power Dissipation	40 mW

Output IC:

Supply voltage - V _{CC}	20 V
Output Current - I _O	20 mA
Output Power Dissipation	50 mW
Output Voltage - V _O	20 V

Package Dimensions

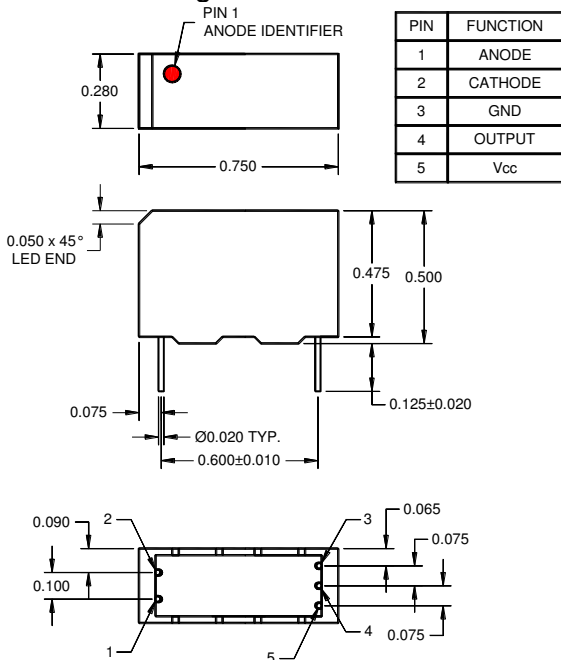

Schematic Diagram

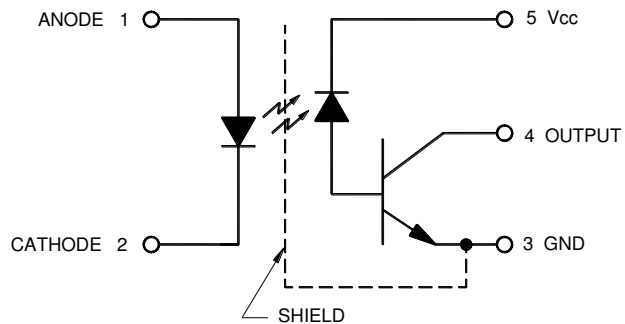

ALL DIMENSIONS ARE IN INCHES UNLESS OTHERWISE SPECIFIED

ELECTRICAL CHARACTERISTICS ($T_A = -40^\circ\text{C}$ to $+100^\circ\text{C}$ unless otherwise specified)

PARAMETER	SYMBOL	MIN	TYP	MAX	UNITS	TEST CONDITIONS	NOTE
Input LED							
Input Forward Voltage	V_F		1.3	1.8	V	$I_F = 20\text{ mA}$	
Reverse Current	I_R			100	μA	$V_R = 3.0\text{ V}$	
Output IC							
Current Transfer Ratio	CTR	9	20		%	$I_F = 16\text{ mA}$, $V_O = 0.4\text{ V}$, $V_{CC} = 4.5\text{ V}$	3
Output Leakage Current	I_{OH1}		70	250	μA	$I_F = 250\text{ }\mu\text{A}$, $V_{CC} = V_O = 18\text{ V}$	
Logic High Output Current	I_{OH}		20	100	μA	$I_F = 0$, $V_{CC} = V_O = 18\text{ V}$	
High Level Supply Current	I_{CCH}		0.02	10	μA	$I_F = 0\text{ mA}$, $V_{CC} = 18\text{ V}$	
Low Level Supply Current	I_{CCL}		35	200	μA	$I_F = 20\text{ mA}$, $V_{CC} = 18\text{ V}$	
Input – Output Isolation Voltage	V_{I-O}	7500			V	$I_{I-O} = 25\text{ }\mu\text{A}$	2
Propagation Delay Time To High Output Level	t_{PLH}		2	6	μs	$I_F = 16\text{ mA}$, $V_{CC} = 5.0\text{ V}$, $R_L = 8.2\text{ k}\Omega$ $C_L = 50\text{ pF}$	
Propagation Delay Time To Low Output Level	t_{PHL}		0.4	2	μs	$I_F = 0.5\text{ mA}$, $V_{CC} = 5.0\text{ V}$, $R_L = 4.7\text{ k}\Omega$ $C_L = 50\text{ pF}$	
Typical Characteristics ($V_{CC} = 5\text{ V}$, $T_A = 25^\circ\text{C}$)							
Input Capacitance	C_{IN}		120		pF	$V_F = 0$, $f = 1\text{ MHz}$	
Coupling Capacitance (Input – Output)	C_{I-O}		1.5		pF	$V_F = 0$, $f = 1\text{ MHz}$	2
Common Mode Transient Immunity At High Output Level	CM_H	500	1000		V/ μs	$V_{CM} = 10\text{ Vp-p}$, $R_L = 8.2\text{ k}\Omega$, $I_F = 0$	4, 6
Common Mode Transient Immunity At Low Output Level	CM_L	500	1000		V/ μs	$V_{CM} = 10\text{ Vp-p}$, $R_L = 8.2\text{ k}\Omega$, $I_F = 16\text{ mA}$	5, 6

NOTES:

- The duration can be extended to 10 seconds maximum when flow soldering. Otherwise 5 seconds with soldering iron.
- Device considered a two terminal device with all Input pins (Anode and Cathode) shorted together and all Output pins (V_{CC} , GND and Output) shorted together.
- CURRENT TRANSFER RATIO is defined as the ratio of output collector current, I_O , to the forward LED input current, I_F , times 100%.
- CM_H is the maximum tolerable common mode transient to assure the output will remain in a HIGH logic state (ie. $V_O > 2.0\text{ V}$).
- CM_L is the maximum tolerable common mode transient to assure the output will remain in a LOW logic state (ie. $V_O < 0.8\text{ V}$).
- In applications where dv/dt may exceed 50,000 V/ μs (such as static discharge) a series resistor, R_{CC} , should be include to protect the detector IC from destructively high surge currents. The recommended value is $R_{CC} = 1\text{V}/(0.6 * I_F)\text{ mA}$.

SELECTION GUIDE

PART #	PART DESCRIPTION
66327-001	Commercial
66327-101	Screened