

# 66326 35 kV HIGH VOLTAGE, 6N140 TYPE HIGH SPEED ISOLATOR



09/17/2009

### Features:

- High Current Transfer Ratio 1000% typical
- 35 kVdc Isolation
- Low input current requirement of 0.5 mA
- Integral Detector Die Faraday Shield for improved Common Mode Rejection

### Applications:

- High Voltage Isolation
- Voltage Level Shifting
- Isolated Receiver Input
- Switching power supplies
- Medical systems

### DESCRIPTION

The **66326** high voltage isolator consists of an 850 nm LED optically coupled to a high gain inverting photon detector. The isolator provides high CTR and low leakage currents over the specified temperature range of -40°C to +100°C. The isolator is built with hermetic components internally optically coupled and encased in a high temperature outer PPS plastic housing.

### ABSOLUTE MAXIMUM RATINGS (T<sub>A</sub> = 25 °C unless otherwise specified)

Isolation Voltage (Input to Output) (Note 2).....	35 kVdc
Operating Free-Air Temperature Range .....	-40°C to +100°C
Storage Temperature.....	-40°C to +100°C
Lead Solder Temperature (10 seconds, 1.6 mm from case) (Note 1).....	260°C

### LED:

Peak Forward Input Current (2 μs duration).....	300mA
Average Forward Input Current .....	50 mA
Reverse Input Voltage .....	3.0V
Input Power Dissipation .....	100 mW

### Output IC:

Supply Voltage - V <sub>CC</sub> .....	-0.5 V to 20 V
Output Voltage - V <sub>O</sub> .....	-0.5 V to 20 V
Output Current - I <sub>O</sub> .....	40 mA
Output Power Dissipation .....	50 mW

### Package Dimensions

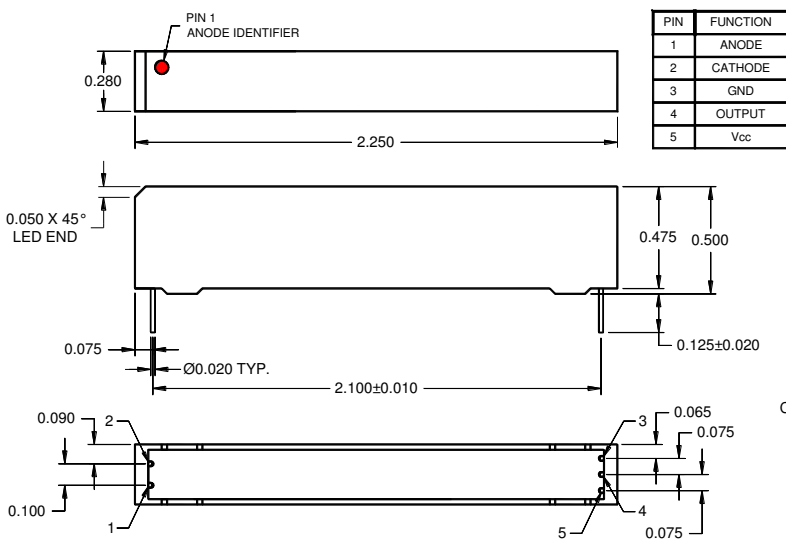

ALL DIMENSIONS ARE IN INCHES UNLESS OTHERWISE SPECIFIED

PIN	FUNCTION
1	ANODE
2	CATHODE
3	GND
4	OUTPUT
5	V <sub>CC</sub>

### Schematic Diagram

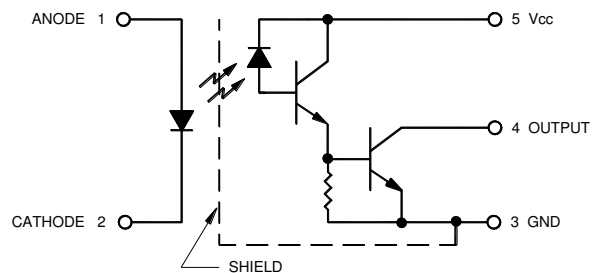

**ELECTRICAL CHARACTERISTICS** ( $T_A = -40^\circ\text{C}$  to  $+100^\circ\text{C}$  unless otherwise specified)

PARAMETER	SYMBOL	MIN	TYP	MAX	UNITS	TEST CONDITIONS	NOTE
<b>Input LED</b>							
Input Forward Voltage	$V_F$		1.3	1.8	V	$I_F = 20 \text{ mA}$	
Reverse Current	$I_R$			100	$\mu\text{A}$	$V_R = 3.0 \text{ V}$	
<b>Output IC</b>							
Current Transfer Ratio	CTR	300	1000		%	$I_F = 0.5 \text{ mA}, V_O = 0.4 \text{ V}, V_{CC} = 4.5 \text{ V}$	3
		300	750			$I_F = 1.6 \text{ mA}, V_O = 0.4 \text{ V}, V_{CC} = 4.5 \text{ V}$	
		200	400			$I_F = 5.0 \text{ mA}, V_O = 0.4 \text{ V}, V_{CC} = 4.5 \text{ V}$	
Low Level Output Voltage	$V_{OL}$		0.1	0.4	V	$I_F = 0.5 \text{ mA}, I_{OL} = 1.5 \text{ mA}, V_{CC} = 4.5 \text{ V}$	
			0.2	0.4		$I_F = 5.0 \text{ mA}, I_{OL} = 10 \text{ mA}, V_{CC} = 4.5 \text{ V}$	
Logic High Output Current	$I_{OH}$		0.005	250	$\mu\text{A}$	$I_F = 2 \mu\text{A}, V_O = V_{CC} = 18 \text{ V}$	
High Level Supply Current	$I_{CCH}$		0.010	40	$\mu\text{A}$	$I_F = 0 \text{ mA}, V_{CC} = 18 \text{ V}$	
Low Level Supply Current	$I_{CCL}$		2	4	mA	$I_F = 1.6 \text{ mA}, V_{CC} = 18 \text{ V}$	
Input – Output Isolation Voltage	$V_{I-O}$	35,000			V	$I_{I-O} = 25 \mu\text{A}$	2
Propagation Delay Time To High Output Level	$t_{PLH}$			60	$\mu\text{s}$	$I_F = 0.5 \text{ mA}, V_{CC} = 5.0 \text{ V}, R_L = 4.7 \text{ k}\Omega$	
				30		$I_F = 5.0 \text{ mA}, V_{CC} = 5.0 \text{ V}, R_L = 680 \Omega$	
Propagation Delay Time To Low Output Level	$t_{PHL}$			100	$\mu\text{s}$	$I_F = 0.5 \text{ mA}, V_{CC} = 5.0 \text{ V}, R_L = 4.7 \text{ k}\Omega$	
				10		$I_F = 5.0 \text{ mA}, V_{CC} = 5.0 \text{ V}, R_L = 680 \Omega$	
<b>Typical Characteristics</b> ( $V_{CC} = 5 \text{ V}, T_A = 25^\circ\text{C}$ )							
Input Capacitance	$C_{IN}$		60		pF	$V_F = 0, f = 1 \text{ MHz}$	
Coupling Capacitance (Input – Output)	$C_{I-O}$		1.5		pF	$V_F = 0, f = 1 \text{ MHz}$	2
Common Mode Transient Immunity At High Output Level	$CM_H$	500	1000		V/ $\mu\text{s}$	$V_{CM} = 50 \text{ Vp-p}, V_{CC} = 5.0 \text{ V}$ $R_L = 1.5 \text{ k}\Omega, I_F = 0$	4, 6
Common Mode Transient Immunity At Low Output Level	$CM_L$	500	1000		V/ $\mu\text{s}$	$V_{CM} = 50 \text{ Vp-p}, V_{CC} = 5.0 \text{ V}$ $R_L = 1.5 \text{ k}\Omega, I_F = 1.6 \text{ mA}$	5, 6

**NOTES:**

- The duration can be extended to 10 seconds maximum when flow soldering. Otherwise 5 seconds with soldering iron.
- Device considered a two terminal device with all Input pins (Anode and Cathode) shorted together and all Output pins ( $V_{CC}$ , GND and Output) shorted together.
- CURRENT TRANSFER RATIO is defined as the ratio of output collector current,  $I_O$ , to the forward LED input current,  $I_F$ , times 100%.
- $CM_H$  is the maximum tolerable common mode transient to assure the output will remain in a HIGH logic state (ie.  $V_O > 2.0 \text{ V}$ ).
- $CM_L$  is the maximum tolerable common mode transient to assure the output will remain in a LOW logic state (ie.  $V_O < 0.8 \text{ V}$ ).
- In applications where  $dv/dt$  may exceed 50,000 V/ $\mu\text{s}$  (such as static discharge) a series resistor,  $R_{CC}$ , should be include to protect the detector IC from destructively high surge currents. The recommended value is  $R_{CC} = 1\text{V}/(0.6 * I_F) \text{ mA}$ .

**SELECTION GUIDE**

PART #	PART DESCRIPTION
66326-001	Commercial
66326-101	Screened