

66322**35 kV HIGH VOLTAGE, 6N134 TYPE HIGH SPEED ISOLATOR**
**OPTOELECTRONIC PRODUCTS
DIVISION**

09/18/2009

Features:

- 2 Mbd Transfer Rate
- 35 kVdc Isolation
- TTL compatible input and output
- Creepage Path: 2.08" min

Applications:

- High Voltage Isolation
- Voltage Level Shifting
- Grid Current Modulator
- Switching between power supplies
- Medical systems

DESCRIPTION

The **66322** high voltage isolator consists of an 850 nm LED optically coupled to a high speed, high gain inverting detector gate. The isolator output is TTL capable with switching propagation delays of 55 ns typical. The high voltage isolator has an operating free-air temperature range of -40°C to +100°C. The isolator is encased in a high temperature outer PPS housing.

ABSOLUTE MAXIMUM RATINGS (T_A=25°C unless otherwise specified)

Isolation Voltage (Input to Output) (Note 2)..... 35 kVdc
 Operating Free-Air Temperature Range -40°C to +100°C
 Storage Temperature..... -40°C to +100°C
 Lead Solder Temperature (10 seconds, 1.6mm from case) (Note 1) 260°C

LED:

Peak Forward Input Current (2 μs duration)..... 300 mA
 Average Forward Input Current 50 mA
 Reverse Input Voltage 3.0 V
 Input Power Dissipation 100 mW

Output IC:

Supply voltage - V_{CC} -0.5 V to 7.0 V (1 minute maximum)
 Output Current - I_O 25 mA
 Output Power Dissipation 40 mW
 Output Voltage - V_O 18 V

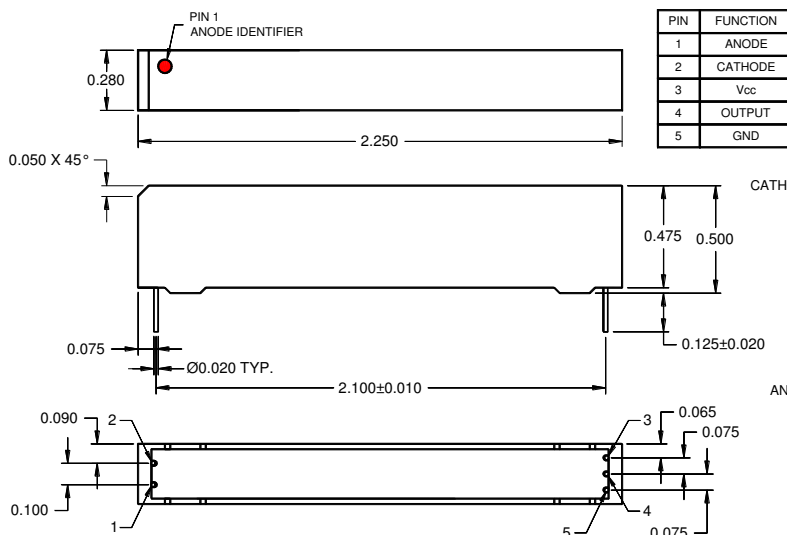
Package Dimensions

ALL DIMENSIONS ARE IN INCHES UNLESS OTHERWISE SPECIFIED

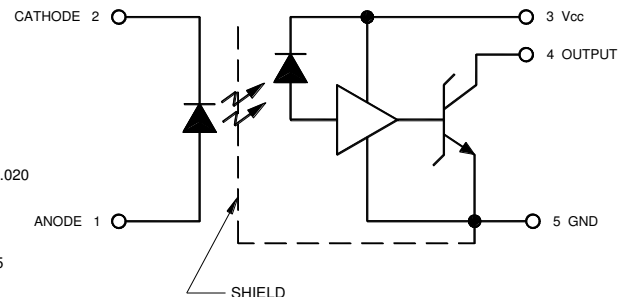
Schematic Diagram

ELECTRICAL CHARACTERISTICS ($T_A = 25^\circ\text{C}$ unless otherwise specified)

PARAMETER	SYMBOL	MIN	TYP	MAX	UNITS	TEST CONDITIONS	NOTE
Input LED							
Input Forward Voltage	V_F		1.3	1.6	V	$I_F = 20\text{ mA}$	
Reverse Current	I_R			100	μA	$V_R = 3.0\text{ V}$	
Output IC							
High Level Output Current	I_{OH}		0.25	15	μA	$V_{CC} = 5.25\text{ V}, V_{OH} = 18\text{ V}, I_F = 0\text{ mA}$	
Low Level Output Voltage	V_{OL}		0.40	0.5	V	$V_{CC} = 4.5\text{ V}, I_F = 10\text{ mA}$ $I_{OL}(\text{Sinking}) = 8.0\text{ mA}$	
High Level Supply Current	I_{CCH}		2.5	7	mA	$V_{CC} = 5.25\text{ V}, I_F = 0\text{ mA}$	
Low Level Supply Current	I_{CCL}		6	10	mA	$V_{CC} = 5.25\text{ V}, I_F = 10\text{ mA}$	
Coupled Characteristics ($V_{CC} = 5\text{ V}$)							
Coupling Capacitance	C_{I-O}			2.0	pF	Input and Output leads shorted	
Propagation Delay Time To High Output Level	t_{PLH}		55	100	ns	$V_{CC} = 5\text{ V}, R_L = 560\ \Omega, I_F = 10\text{ mA}, C_L = 15\text{ pF}$	
Propagation Delay Time To Low Output Level	t_{PHL}		55	200	ns	$V_{CC} = 5\text{ V}, R_L = 560\ \Omega, I_F = 10\text{ mA}, C_L = 15\text{ pF}$	
Difference in Propagation Delays	$t_{PHL} - t_{PLH}$			100	ns		
Input – Output Isolation Voltage	V_{I-O}	35,000			V	$I_{I-O} = 25\ \mu\text{A}$	2
LED Positive going Threshold Current	I_{F+}	0.9	4.0	10.0	mA	$V_{CC} = 5.0\text{ V}, I_{OL} = 8.0\text{ mA}$	

NOTES:

- 1) The duration can be extended to 10 seconds maximum when flow soldering. Otherwise 5 seconds with soldering iron.
- 2) Device considered a two terminal device with all Input pins (Anode and Cathode) shorted together and all Output pins (V_{CC} , GND and Output) shorted together.

SELECTION GUIDE

PART #	PART DESCRIPTION
66322-001	Commercial
66322-101	Screened