

**66321** 25 kV HIGH VOLTAGE, 6N134 TYPE HIGH SPEED ISOLATOR



OPTOELECTRONIC PRODUCTS  
DIVISION

09/18/2009

**Features:**

- 2 Mbd Transfer Rate
- 25 kVdc Isolation
- TTL compatible input and output
- Creepage Path: 1.58" min

**Applications:**

- High Voltage Isolation
- Voltage Level Shifting
- Grid Current Modulator
- Switching between power supplies
- Medical systems

**DESCRIPTION**

The **66321** high voltage isolator consists of an 850 nm LED optically coupled to a high speed, high gain inverting detector gate. The isolator output is TTL capable with switching propagation delays of 55 ns typical. The high voltage isolator has an operating free-air temperature range of -40°C to +100°C. The isolator is encased in a high temperature outer PPS housing.

**ABSOLUTE MAXIMUM RATINGS (T<sub>A</sub>=25°C unless otherwise specified)**

Isolation Voltage (Input to Output) (Note 2)	25 kVdc
Operating Free-Air Temperature Range	-40°C to +100°C
Storage Temperature	-40°C to +100°C
Lead Solder Temperature (10 second, 1.6mm from case) (Note 1)	260°C

**LED:**

Peak Forward Input Current (2 μs duration)	300 mA
Average Forward Input Current	50 mA
Reverse Input Voltage	3.0 V
Input Power Dissipation	100 mW

**Output IC:**

Supply voltage - V <sub>CC</sub>	-0.5V to 7.0V (1 minute maximum)
Output Current - I <sub>O</sub>	25 mA
Output Power Dissipation	40 mW
Output Voltage - V <sub>O</sub>	18 V

**Package Dimensions**

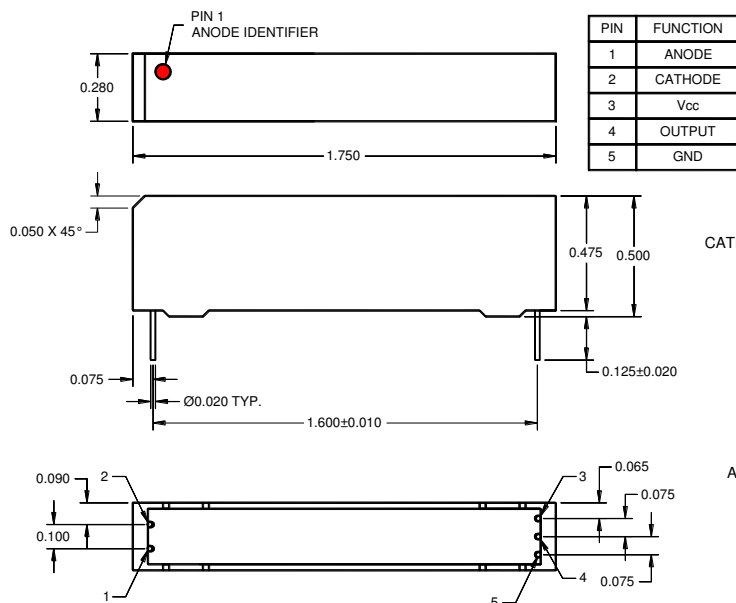

**Schematic Diagram**

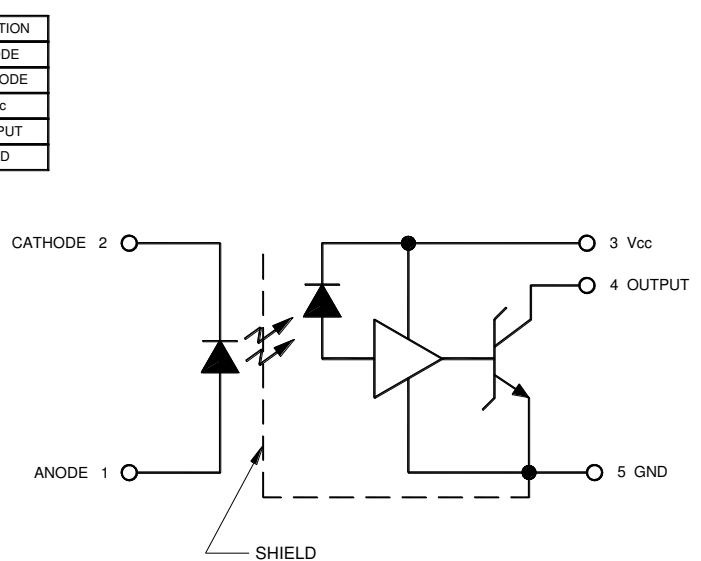

ALL DIMENSIONS ARE IN INCHES UNLESS OTHERWISE SPECIFIED

**ELECTRICAL CHARACTERISTICS** ( $T_A = 25^\circ\text{C}$  unless otherwise specified)

PARAMETER	SYMBOL	MIN	TYP	MAX	UNITS	TEST CONDITIONS	NOTE
<b>Input LED</b>							
Input Forward Voltage	$V_F$		1.3	1.6	V	$I_F = 20\text{ mA}$	
Reverse Current	$I_R$			100	$\mu\text{A}$	$V_R = 3.0\text{ V}$	
<b>Output IC</b>							
High Level Output Current	$I_{OH}$		0.25	15	$\mu\text{A}$	$V_{CC} = 5.25\text{ V}$ , $V_{OH} = 18\text{ V}$ , $I_F = 0\text{ mA}$	
Low Level Output Voltage	$V_{OL}$		0.40	0.5	V	$V_{CC} = 4.5\text{ V}$ , $I_F = 10\text{ mA}$ $I_{OL}(\text{Sinking}) = 8.0\text{ mA}$	
High Level Supply Current	$I_{CCH}$		2.5	7	mA	$V_{CC} = 5.25\text{ V}$ , $I_F = 0\text{ mA}$	
Low Level Supply Current	$I_{CCL}$		6	10	mA	$V_{CC} = 5.25\text{ V}$ , $I_F = 10\text{ mA}$	
<b>Coupled Characteristics</b> ( $V_{CC} = 5\text{ V}$ )							
Coupling Capacitance	$C_{I-O}$			2.0	pF	Input and Output leads shorted	
Propagation Delay Time To High Output Level	$t_{PLH}$		55	100	ns	$V_{CC} = 5\text{ V}$ , $R_L = 560\ \Omega$ , $I_F = 10\text{ mA}$ , $C_L = 15\text{ pF}$	
Propagation Delay Time To Low Output Level	$t_{PHL}$		55	200	ns	$V_{CC} = 5\text{ V}$ , $R_L = 560\ \Omega$ , $I_F = 10\text{ mA}$ , $C_L = 15\text{ pF}$	
Difference in Propagation Delays	$t_{PHL} - t_{PLH}$			100	ns		
Input – Output Isolation Voltage	$V_{I-O}$	25,000			V	$I_{I-O} = 25\ \mu\text{A}$	2
LED Positive going Threshold Current	$I_{F+}$	0.9	4.0	10.0	mA	$V_{CC} = 5.0\text{ V}$ , $I_{OL} = 8.0\text{ mA}$	

**NOTES:**

- 1) The duration can be extended to 10 seconds maximum when flow soldering. Otherwise 5 seconds with soldering iron.
- 2) Device considered a two terminal device with all Input pins (Anode and Cathode) shorted together and all Output pins ( $V_{CC}$ , GND and Output) shorted together.

**SELECTION GUIDE**

PART #	PART DESCRIPTION
66321-001	Commercial
66321-101	Screened