

66181 30kV HIGH VOLTAGE ISOLATOR WITH BUFFERED OUTPUT



09/24/03

Features:

- 10 Mhz bandwidth typical
- 30 kVdc isolation test voltage
- TTL compatible input and output
- High common mode rejection
- Rugged ceramic package

Applications:

- Military and Space
- Voltage Level Shifting
- Grid Current Modulator
- Switching between power supplies
- Medical systems

DESCRIPTION

The **66181** high voltage isolator consisting of an LED optically coupled to a high speed, high gain inverting detector gate. Output is TTL capable with switching propagation delays of 55ns typical, hermetically sealed in TO-46 packages and mounted in a highly reliability, hermetically sealed ceramic package. Available in commercial (0° to +70°C), extended temperature range (-40° to +85°) and full Military temperature range (-55° to +125°C). **Contact the factory for special custom or multi-channel requirements!**

ABSOLUTE MAXIMUM RATINGS

Peak Forward Input Current (1ms duration)	40 mA
Average Forward Input Current	20 mA
Input Power Dissipation	35 mW
Reverse Input Voltage	5 V
Supply voltage - V_{CC} (1 minute maximum)	7 V
Output Current - I_O	25 mA
Output Power Dissipation	40 mW
Output Voltage - V_O	7 V
Total Power Dissipation	350 mW
Storage Temperature	-65°C to +150°C
Operating Free-Air Temperature Range	-55°C to +125°C
Lead Solder Temperature (10 seconds, 1/16" from case)	260°C

Package Dimensions

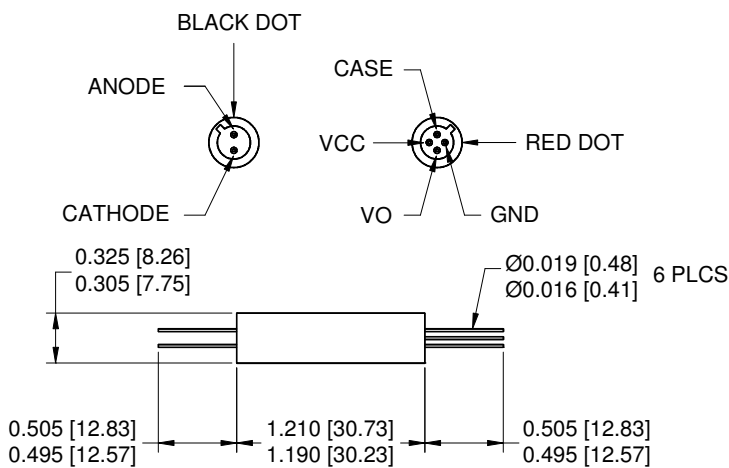

NOTE:

BLACK DOT INDICATES ANODE OF LED.
RED DOT INDICATES DETECTOR GROUND

ALL DIMENSIONS ARE IN INCHES [MILLIMETERS]

Schematic Diagram

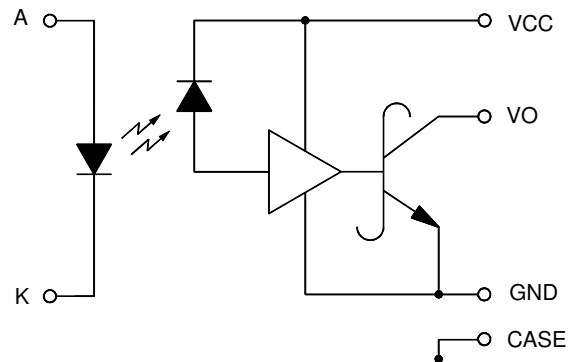

66181**30kV HIGH VOLTAGE ISOLATOR WITH BUFFERED OUTPUT**

09/24/03

ELECTRICAL CHARACTERISTICST_A = 25°C unless otherwise specified.

PARAMETER	SYMBOL	MIN	TYP	MAX	UNITS	TEST CONDITIONS	NOTE
High Level Output Current	I _{OH}		5	250	μA	V _{CC} = 5.5V, V _O = 5.5V, I _F = 20μA	
Low Level Output Voltage	V _{OL}		0.35	0.6	V	V _{CC} = 5.5V, I _F = 10mA I _{OL} (Sinking) = 10mA	
High Level Supply Current	I _{CCH}		9	20	mA	V _{CC} = 5.5V, I _F = 0	
Low Level Supply Current	I _{CCL}		13	30	mA	V _{CC} = 5.5V, I _F = 20mA	
Input Forward Voltage	V _F		1.5	1.75	V	I _F = 15mA	
Input Reverse Breakdown Voltage	BV _R	5			V	I _R = 10μA	
Input-Output Insulation Leakage Current	I _{I-O}			10.0	μA	V _{I-O} = 30kVdc, Relative Humidity = 45% T _a = 25°C, t = 5 sec	1
Propagation Delay Time To High Output Level	t _{PLH}		65	110	ns	R _L = 510Ω, C _L = 15Pf. I _f = 13mA	2
Propagation Delay Time To Low Output Level	t _{PHL}		55	95	ns	R _L = 510Ω, C _L = 15Pf I _f = 13mA	3

TYPICAL CHARACTERISTICST_A = 25°C, V_{CC} = 5V

PARAMETER	SYMBOL	MIN	TYP	MAX	UNITS	TEST CONDITIONS	NOTE
Input Diode Temperature Coefficient	$\frac{\Delta V_F}{\Delta T_A}$		-1.9		mV/°C	I _F = 20mA	
Resistance (Input-Output)	R _{I-O}		10 ¹²		Ω	V _{I-O} = 500V	1
Common Mode Transient Immunity at High Output Level	CM _H	1000	10000		V/μs	V _{CM} = 10V (peak), V _O (min) = 2V, R _L = 510Ω, I _F = 0mA	4
Common Mode Transient Immunity at Low Output Level	CM _L	1000	10000		V/μs	V _{CM} = 10V (peak), V _O (max) = 0.8V, R _L = 510Ω, I _F = 10mA	5

NOTES:

1. Measured between input pins shorted together and output pins shorted together.
2. The t_{PLH} propagation delay is measured from the 6.5mA point on the trailing edge of the input pulse to the 1.5V point on the trailing edge of the output pulse.
3. The t_{PHL} propagation delay is measured from the 6.5mA point on the leading edge of the input pulse to the 1.5V point on the leading edge of the output pulse.
4. CM_H is the max. tolerable common mode transient to assure that the output will remain in a high logic state (i.e. V_O > 2.0V).
5. CM_L is the max. tolerable common mode transient to assure that the output will remain in a low logic state (i.e. V_O < 0.8V).
6. It is essential that a bypass capacitor (.01 to 0.1μF ceramic) be connected from VCC pin to GND pin.

RECOMMENDED OPERATING CONDITIONS:

PARAMETER	SYMBOL	MIN	MAX	UNITS
Input Current, Low Level Each Channel	I _{FL}	0	250	μA
Input Current, High Level Each Channel	I _{FH}	12.5	20	mA
Supply Voltage	V _C	4.5	5.5	V
Fan Out (TTL Load) Each Channel	N		6	
Operating Temperature	T _A	-55	125	°C

SELECTION GUIDE

PART #	PART DESCRIPTION
66181-001	Screened (-55° to +125°C)
66181-101	(-55° to +125°C) with 100% device screening (on discrete components)
66181-011	Commercial (0° to 70°C)