

66500**MICROCOUPLER, HIGH SPEED-HIGH GAIN
INVERTED OUTPUT**

05/29/03

Features:

- High speed, high gain inverted output
- Small size saves real estate
- Large thick film gold bond pads
- Element evaluation on request
- Electrically similar to 6N134

Applications:

- Eliminate ground loops
- Level shifting
- Line receiver
- Solid state switching
- Switching power supplies

DESCRIPTION

The **66500** microcoupler is a single channel optocoupler consisting of an LED optically coupled to a high speed, high gain inverting photodetector. Each microcoupler is provided with full 100% DC testing (+125°C test option upon request) or 100% element evaluation. All microcouplers are capable of operating over the full military temperature range.

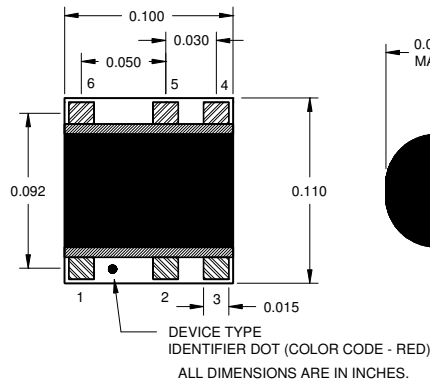
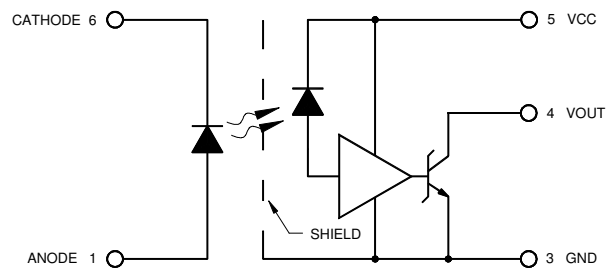
Package Dimensions**Schematic Diagram****ELECTRICAL CHARACTERISTICS** $T_A = -55^\circ\text{C}$ to at 125°C unless otherwise specified.

PARAMETER	SYMBOL	MIN	TYP	MAX	UNITS	TEST CONDITIONS	NOTE
High Level Output Current	I_{OH}		5	250	μA	$V_{CC} = 5.5\text{V}$, $V_O = 5.5\text{V}$, $I_F = 250\mu\text{A}$	
Low Level Output Voltage	V_{OL}		0.3	0.6	V	$V_{CC} = 5.0\text{V}$, $I_F = 5\text{mA}$ $I_{OL} = 5\text{mA}$	
			0.4	0.6		$V_{CC} = 5.5\text{V}$, $I_F = 5\text{mA}$ $I_{OL} = 10\text{mA}$	
High Level Supply Current	I_{CCH}		9	13	mA	$V_{CC} = 5.5\text{V}$, $I_F = 0\text{mA}$	
Low Level Supply Current	I_{CCL}		11	16	mA	$V_{CC} = 5.5\text{V}$, $I_F = 5\text{mA}$ $I_{OL} = 5\mu\text{A}$, $V_{OL} = 0.6\text{V}$	
Input Forward Voltage	V_F		1.5	1.85	V	$I_F = 10\text{mA}$	
		0.9		1.7	V	$I_F = 2\text{mA}$	
Input Reverse Current	I_R			10	μA	$V_R = 5\text{V}$	
On State Forward Current	$I_{F(ON)}$	1		5	mA	$V_{CC} = 5.0\text{V}$, $I_{OL} = 2\text{mA}$	
Propagation Delay Time To High Output Level	T_{PLH}		60	140	ns	$R_L = 510\Omega$, $C_{Bypass} = 0.1\mu\text{F}$. $I_f = 5\text{mA}$ (pulsed), $V_{CC} = 5\text{V}$	2 Figure 1
Propagation Delay Time To Low Output Level	T_{PHL}		60	140	ns	$R_L = 510\Omega$, $C_{Bypass} = 0.1\mu\text{F}$. $I_f = 5\text{mA}$ (pulsed), $V_{CC} = 5\text{V}$	2 Figure 1
Input-Output Insulation Leakage Current	I_{I-O}			1	μA	$V_{I-O} = 1500\text{V}$, R.H. < 50% $T_A = 25^\circ\text{C}$	1
Common Mode Transient Immunity at High Output Level	CM_H	1000	10000		V/ μs	$R_L = 510\Omega$, $V_{CM} = 50\text{V}$ peak $I_f = 0\text{mA}$, $V_O(\text{min}) = 2\text{V}$	2
Common Mode Transient Immunity at Low Output Level	CM_L	1000	10000		V/ μs	$R_L = 510\Omega$, $V_{CM} = 50\text{V}$ peak $I_f = 5\text{mA}$, $V_O(\text{min}) = 0.8\text{V}$	2

NOTES:

1. Measurement between pins 1 and 6 shorted together and pins 3, 4 and 5 shorted together for duration of 1 second.
2. Pulsed at $F = 10\text{KHz}$, 50% Duty Cycle and Amplitude adjusted for equivalent of 5mA through I_F monitor resistor.

RECOMMENDED OPERATING CONDITIONS:

PARAMETER	SYMBOL	MIN	MAX	UNITS
Input Current, Low Level Each Channel	I_{FL}	0	250	μA
Input Current, High Level Each Channel	I_{FH}	12.5	20	mA
Supply Voltage	V_C	4.5	5.5	V
Fan Out (TTL Load) Each Channel	N		6	
Operating Temperature	T_A	-55	125	$^{\circ}C$

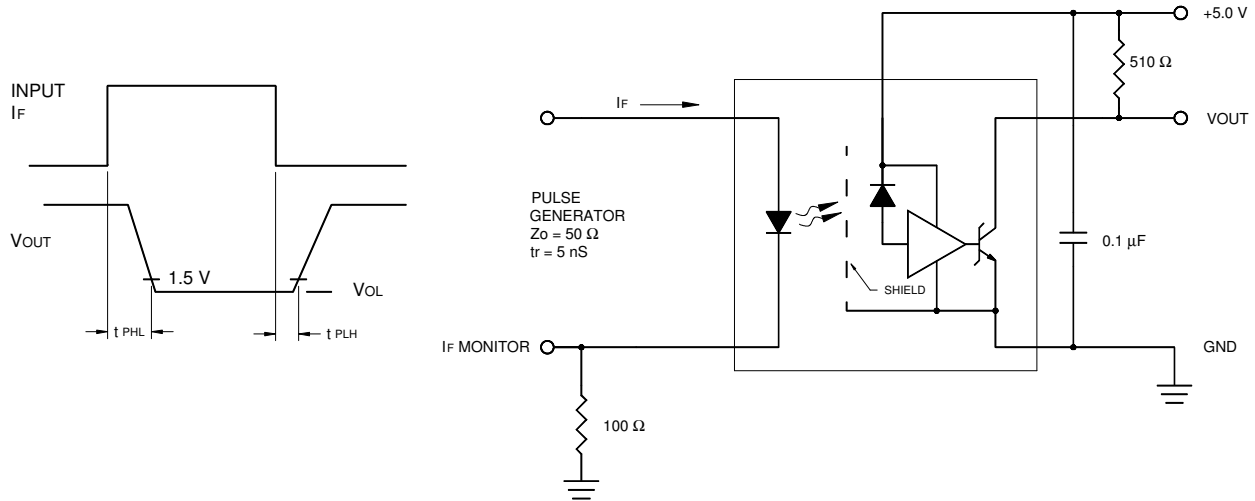

Figure 1. Switching Test Circuit.