

**66400****MICROCOUPLER, PHOTODARLINGTON OUTPUT**

05/29/03

**Features:**

- Photodarlington output
- Small size saves real estate
- Large thick film gold bond pads
- Element evaluation on request
- Electrically similar to 6N140

**Applications:**

- Eliminate ground loops
- Level shifting
- Line receiver
- Solid state switching
- Switching power supplies

**DESCRIPTION**

The **66400** microcoupler is a single channel optocoupler consisting of an LED optically coupled to a light sensitive photodarlington transistor. Each microcoupler is provided with full 100% DC testing (+125°C test option upon request) or 100% element evaluation. All microcouplers are capable of operating over the full military temperature range.

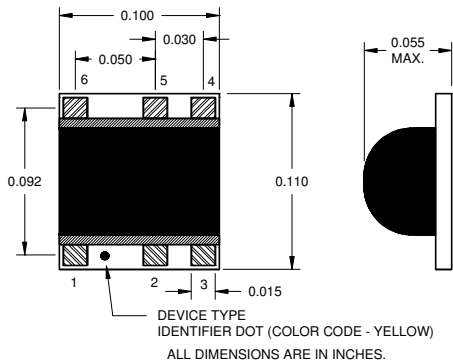
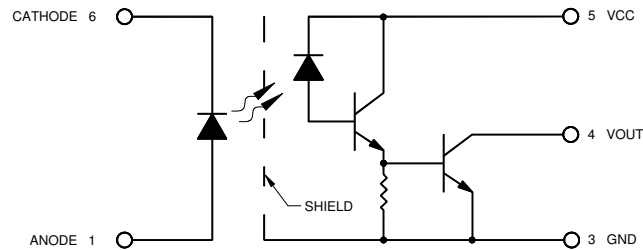
**Package Dimensions****Schematic Diagram****ELECTRICAL CHARACTERISTICS**

$T_A = -55^\circ\text{C}$  to  $125^\circ\text{C}$  unless otherwise specified.

PARAMETER	SYMBOL	MIN	TYP	MAX	UNITS	TEST CONDITIONS	NOTE
Current Transfer Ratio	CTR	300			%	$I_F = 0.5\text{mA}$ , $V_O = 0.4\text{V}$ , $V_{CC} = 4.5\text{V}$	1
		300				$I_F = 1.6\text{mA}$ , $V_O = 0.4\text{V}$ , $V_{CC} = 4.5\text{V}$	
		200				$I_F = 5.0\text{mA}$ , $V_O = 0.4\text{V}$ , $V_{CC} = 4.5\text{V}$	
Logic Low Output Voltage	$V_{OL}$		0.1	0.4	V	$I_F = 0.5\text{mA}$ , $I_{OL} = 1.5\text{mA}$ , $V_{CC} = 4.5\text{V}$	
			0.2	0.4		$I_F = 5.0\text{mA}$ , $I_{OL} = 10\text{mA}$ , $V_{CC} = 4.5\text{V}$	
Logic High Output Current	$I_{OH}$		0.005	250	$\mu\text{A}$	$I_F = 2.0\mu\text{A}$ , $V_O = 18.0\text{V}$ , $V_{CC} = 18.0\text{V}$	
Logic High Supply Current	$I_{CCH}$		0.01	40	$\mu\text{A}$	$I_F = 0\text{mA}$ , $V_{CC} = 18\text{V}$	
Low Level Supply Current	$I_{CCL}$		0.8	2	mA	$I_F = 1.6\text{mA}$ , $V_{CC} = 18\text{V}$	
Input Forward Voltage	$V_F$	0.9		1.7	V	$I_F = 2.0\text{mA}$	
Input Reverse Current	$I_R$			10	$\mu\text{A}$	$V_R = 5.0\text{V}$	
Input-Output Insulation Leakage Current	$I_{I-O}$			1.0	$\mu\text{A}$	$V_{I-O} = 1500\text{VDC}$ , R.H. < 50% $T_A = 25^\circ\text{C}$	2
Propagation Delay Time To High Output Level	$T_{PLH}$		5	60	$\mu\text{s}$	$I_F = 0.5\text{mA}$ (pulsed), $V_{CC} = 5.0\text{V}$ , $R_L = 4.7\text{K}\Omega$ , $C_{bypass} = 0.1\mu\text{F}$	3 Figure 1
			10	30		$I_F = 5.0\text{mA}$ (pulsed), $V_{CC} = 5.0\text{V}$ , $R_L = 680\Omega$ , $C_{bypass} = 0.1\mu\text{F}$	
Propagation Delay Time To Low Output Level	$T_{PHL}$		8	100	$\mu\text{s}$	$I_F = 0.5\text{mA}$ (pulsed), $V_{CC} = 5.0\text{V}$ , $R_L = 4.7\text{K}\Omega$ , $C_{bypass} = 0.1\mu\text{F}$	3 Figure 1
			2	10		$I_F = 5.0\text{mA}$ (pulsed), $V_{CC} = 5.0\text{V}$ , $R_L = 680\Omega$ , $C_{bypass} = 0.1\mu\text{F}$	

1. Current Transfer Ratio is defined as the ratio of output collector current,  $I_O$ , to the forward LED input current,  $I_F$ , times 100%.
2. Measurement between pins 1 and 6 shorted together and pins 2, 3, 4, and 5 shorted together for duration of 1 second.
3. Pulsed at  $F = 10\text{KHz}$ , 50% Duty Cycle and Amplitude adjusted for indicated forward LED current through  $I_F$  monitor resistor.

05/29/03

RECOMMENDED OPERATING CONDITIONS:

PARAMETER	SYMBOL	MIN	MAX	UNITS
Input Current, Low Level	$I_{FL}$	0	2	$\mu A$
Input Current, High Level	$I_{FH}$	0.5	5	mA
Supply Voltage	$V_{CC}$	2.0	18	V

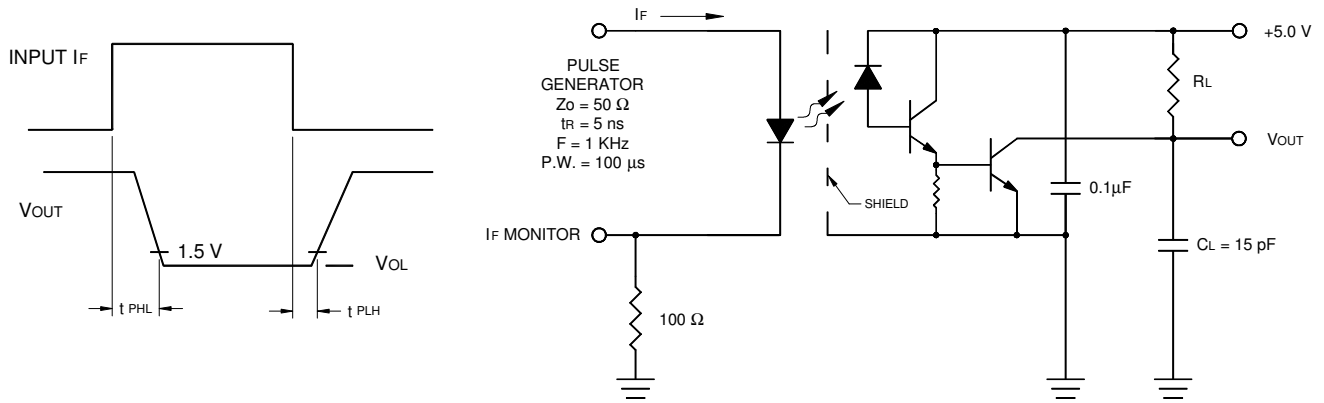

Figure 1. Switching Test Circuit