

66124

DUAL CHANNEL, HERMETICALLY SEALED 20 PIN LCC,
OPTOCOUPLER ELECTRICALLY SIMILAR TO 6N140



6/30/03

Features:

- DSCC Approved 89785022X
- High current transfer ratio: 1000% typical
- 1500 Vdc isolation test voltage
- Low input current requirement: 0.5mA
- Low power consumption
- High radiation immunity
- Faraday shield to provide high common mode rejection

Applications:

- Military and Space
- High reliability systems
- Voltage Level Shifting
- Isolated Receiver Input
- Communication systems
- Medical systems

DESCRIPTION

The **66124** optocoupler consists of two infrared LEDs optically coupled to two corresponding high gain darlington detectors. This unique dual optocoupler provides high CTR and low leakage currents over the full military temperature range (-55° to +125°C). The 66124 is a 20pin leadless chip carrier hermetically sealed package and is available in standard and screened versions or tested to customer specifications. MIL-PRF-38534.

ABSOLUTE MAXIMUM RATINGS

(No derating required up to 125°C)

Peak Forward Input Current (each channel, ≤ 1ms duration)	20mA
Average Forward Input Current (each channel)	10mA
Input Power Dissipation (each channel)	35mW
Reverse Input Voltage (each channel)	5V
Supply Voltage - V _{CC}	-0.5 to +20 V
Output Current - I _O (each channel)	40 mA
Output Power Dissipation (each channel)	50 mW
Output Voltage - V _O (each channel)	-0.5 to +20 V
Total Power Dissipation	350mW
Storage Temperature	-65°C to +150°C
Operating Free-Air Temperature Range	-55°C to +125°C
Lead Solder Temperature (10 seconds)	260°C

Package Dimensions

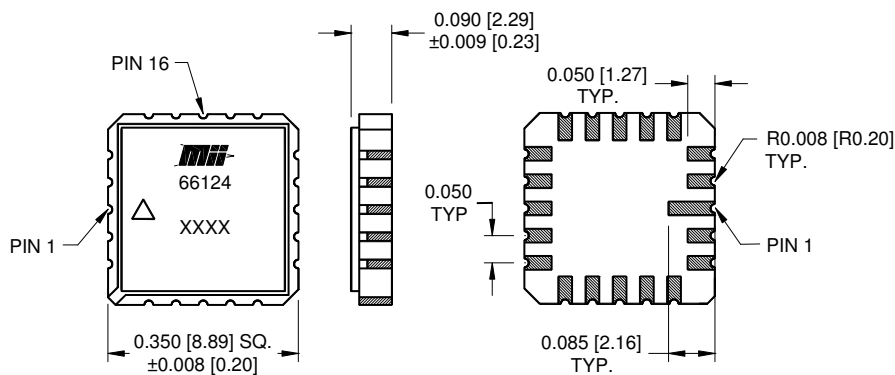

ALL DIMENSIONS ARE IN INCHES [MILLIMETERS]

Schematic Diagram

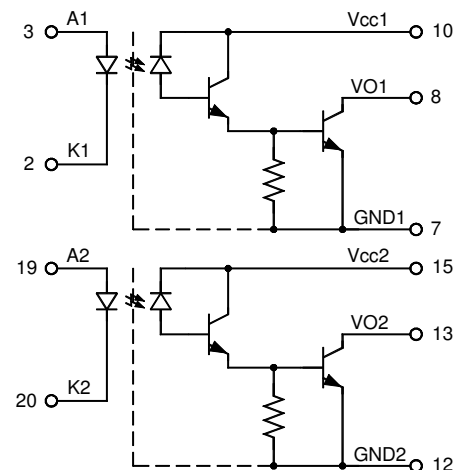

66124

DUAL CHANNEL, HERMETICALLY SEALED 20 PIN LCC, OPTOCOUPLER SIMILAR TO 6N140

6/30/03

ELECTRICAL CHARACTERISTICS

T_a = -55°C to 125°C unless otherwise specified.

PARAMETER	SYMBOL	MIN	TYP	MAX	UNITS	TEST CONDITIONS	NOTE
Current Transfer Ratio	CTR	300	1000		%	I _F = 0.5mA, V _O = 0.4V, V _{CC} = 4.5V	1,2
		300	750		%	I _F = 1.6mA, V _O = 0.4V, V _{CC} = 4.5V	1,2
		200	400		%	I _F = 5.0mA, V _O = 0.4V, V _{CC} = 4.5V	1,2
Logic Low Output Voltage	V _{OL}		0.2	0.4	V	I _F = 0.5mA, I _{OL} = 1.5mA, V _{CC} = 4.5V	1
			0.1	0.4	V	I _F = 1.6mA, I _{OL} = 4.8mA, V _{CC} = 4.5V	
			0.1	0.4	V	I _F = 5.0mA, I _{OL} = 10mA, V _{CC} = 4.5V	
Logic High Output Current	I _{OH}		.005	250	μA	I _F = 2μA, V _O = V _{CC} = 18V	1,3
High Level Output Current	I _{CCH}			40	μA	I _{F1} = I _{F2} = 0mA, V _{CC} = 18V	
Low Level Supply Current	I _{CCL}		1	4	mA	I _{F1} = I _{F2} = 1.6mA, V _{CC} = 18V	
Input Forward Voltage	V _F		1.4	1.8	V	I _F = 1.6mA	1
Input Reverse Breakdown Voltage	BV _R	5			V	I _R = 10μA	1
Input-Output Insulation Leakage Current	I _{I-O}			1.0	μA	V _{I-O} = 1500Vdc, Relative Humidity = 45% t _A = 25°C, t = 5s	4
Propagation Delay Time To High Output Level	t _{PLH}			60	μs	I _F = 0.5mA, V _{CC} = 5.0V, R _L = 4.7kΩ	
				50	μs	I _F = 1.6mA, V _{CC} = 5.0V, R _L = 1.5kΩ	
				30	μs	I _F = 5mA, V _{CC} = 5.0V, R _L = 680Ω	
Propagation Delay Time To Low Output Level	t _{PHL}			100	μs	I _F = 0.5mA, V _{CC} = 5.0V, R _L = 4.7kΩ	
				30	μs	I _F = 1.6mA, V _{CC} = 5.0V, R _L = 1.5kΩ	
				10	μs	I _F = 5mA, V _{CC} = 5.0V, R _L = 680Ω	

TYPICAL CHARACTERISTICS

T_a = 25°C, V_{CC} = 5V Each Channel

PARAMETER	SYMBOL	MIN	TYP	MAX	UNITS	TEST CONDITIONS	NOTE
Capacitance (Input-Output)	C _{I-O}		1.5		pF	f = 1MHz, t _a = 25°C	1, 4
Resistance (Input-Output)	R _{I-O}		10 ¹²		Ω	V _{I-O} = 500V, t _a = 25°C	1, 4
Common Mode Transient immunity at High Output Level	CM _H	500	1000		V/μs	V _{CM} = 50V P-P, V _{CC} = 5.0V, R _L = 1.5kΩ, I _F = 0mA t _a = 25°C	5
Common Mode Transient Immunity at Low Output Level	CM _L	500	1000		V/μs	V _{CM} = 50V P-P, V _{CC} = 5.0V, R _L = 1.5kΩ, I _F = 1.6mA t _a = 25°C	6

NOTES:

- Each channel.
- CURRENT TRANSFER RATIO is defined as the ratio of output collector current, I_O, to the forward LED input current, I_F, times 100%.
- I_F = 2μA for channel under test. For all other channels, I_F = 10mA.
- Measured with input pins shorted together and output pins shorted together.
- CM_H is the maximum tolerable common mode transient to assure that the output will remain in a high logic state (ie. V_O > @ 2.0V).
- CM_L is the maximum tolerable common mode transient to assure that the output will remain in a low logic state (ie. V_O < 0.8V).

RECOMMENDED OPERATING CONDITIONS:

PARAMETER	SYMBOL	MIN	MAX	UNITS
Input Current, Low Level	I _{FL}	0	2	μA
Input Current, High Level	I _{FH}	0.5	5	mA
Supply Voltage	V _{CC}	2.0	18	V

SELECTION GUIDE

PART NUMBER	PART DESCRIPTION
66124-001	Screened
66124-002	-55°C to +125°C mil-temp
66124-003	Commercial