

66015 **3N243**
3N244 **TO-18 OPTOCOUPLERS**
3N245



05/29/03

Features:

- High Reliability
- Base lead eliminated for improved noise immunity
- Rugged package
- Stability over wide temperature
- 1kV electrical isolation

Applications:

- Eliminate ground loops
- Level shifting
- Line receiver
- Switching power supplies
- Motor control

DESCRIPTION

The **66015** contains an infrared LED optically coupled to a silicon phototransistor in a hermetic 4 lead TO-18 package. The collector of the phototransistor is electrically connected to the case. The internal base connection has been eliminated for improved noise immunity. The 3N243, 3N244 and 3N245 can be supplied to commercial or screened quality levels as well as to customer specifications.

ABSOLUTE MAXIMUM RATINGS

Input to Output Voltage	1000V
Emitter-Collector Voltage	7V
Collector-Emitter Voltage	35V
Reverse Input Voltage	2V
Input Diode Continuous Forward Current at (or below) 65°C Free-Air Temperature (see note 1)	40mA
Continuous Collector Current	50mA
Continuous Transistor Power Dissipation at (or below) 25°C Free-Air Temperature (see Note 2)	190mW
Storage Temperature	-55°C to +150°C
Operating Free-Air Temperature Range.....	-55°C to +125°C
Lead Solder Temperature (10 seconds max, 1/16" from case)	240°C

Notes:

1. Derate linearly to 125°C free-air temperature at the rate of 0.67 mA/°C.
2. Derate linearly to 125°C free-air temperature at the rate of 1.9 mW/°C.

Package Dimensions

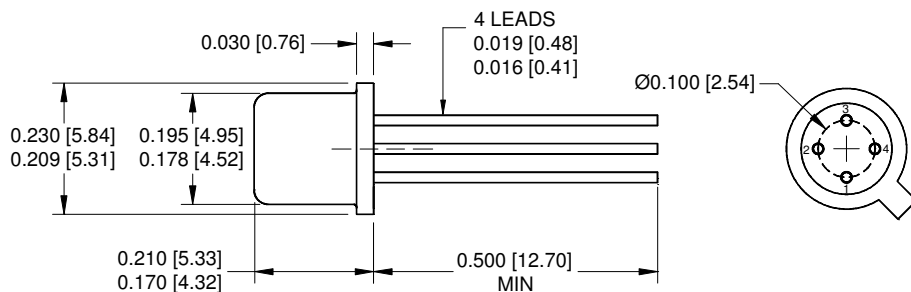

ALL DIMENSIONS ARE IN INCHES [MILLIMETERS]

Schematic Diagram

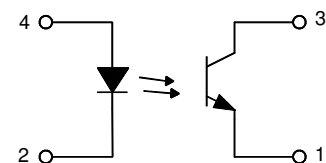

THE COLLECTOR IS IN ELECTRICAL CONTACT WITH THE CASE.

66015 **3N243**
 3N244
 3N245

TO-18 OPTOCOUPLER

05/29/03

ELECTRICAL CHARACTERISTICS

INPUT LED

T_A = 25°C

PARAMETER		MIN	TYP	MAX	UNITS	TEST CONDITIONS
Input Diode Static Forward Voltage	V _F	0.8		1.3	V	I _F = 10mA
Input Diode Reverse Current	I _R			100	μA	V _R = 2 V

OUTPUT TRANSISTOR

T_A = 25°C

PARAMETER	SYMBOL	MIN	TYP	MAX	UNITS	TEST CONDITIONS
Collector-Emitter Breakdown Voltage	V _{(BR)CEO}	35			V	I _C = 1mA, I _F = 0
Emitter-Collector Breakdown Voltage	V _{(BR)ECO}	7			V	I _E = 100μA, I _F = 0
Collector-Emitter Dark Current	I _D			100	nA	V _{CE} = 10V, I _F = 0mA

COUPLED CHARACTERISTICS

T_A = 25°C unless otherwise specified.

PARAMETER		SYMBOL	MIN	TYP	MAX	UNITS	TEST CONDITIONS
On State Collector Current	3N243 3N244 3N245	I _{C(ON)}	1.5 3.0 6.0			mA	V _{CE} = 10V, I _F = 10mA
Collector-Emitter Saturation Voltage	3N243 3N244 3N245	V _{CE(SAT)}			0.3 0.3 0.3	V V V	I _F = 20mA, I _C = 1.5mA I _F = 20mA, I _C = 3mA I _F = 20mA, I _C = 6mA
DC Isolation Voltage		V _{IO}	1000			V	I _{IO} = 100nA
Rise Time	3N243 3N244 3N245	t _r		3 3 6	20 20 20	μs	V _{CE} = 10V, I _F = 10mA, R _L = 100Ω
Fall Time	3N243 3N244 3N245	t _f		3 3 6	20 20 20	μs	V _{CE} = 10V, I _F = 10mA, R _L = 100Ω

RECOMMENDED OPERATING CONDITIONS:

PARAMETER	SYMBOL	MIN	MAX	UNITS
Input Current, Low Level	I _{FL}	0	10	μA
Input Current, High Level	I _{FH}	1	20	mA
Supply Voltage	V _{CE}	5	10	V

SELECTION GUIDE

PART NUMBER	PART DESCRIPTION
66015-001	3N243, Commercial
66015-002	3N244, Commercial
66015-003	3N245, Commercial
66015-101	3N243, Screened
66015-102	3N244, Screened
66015-103	3N245, Screened

05/29/03

PARAMETER MEASUREMENT INFORMATION

ADJUST AMPLITUDE OF INPUT PULSE FOR
 $I_{C(ON)} = 5 \text{ mA}$

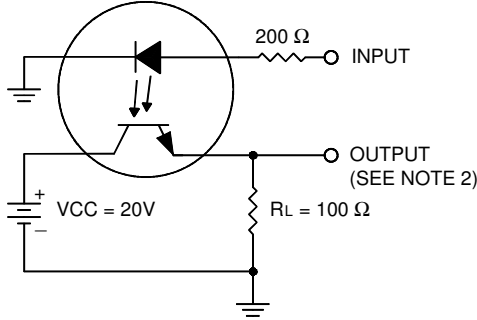

TEST CIRCUIT

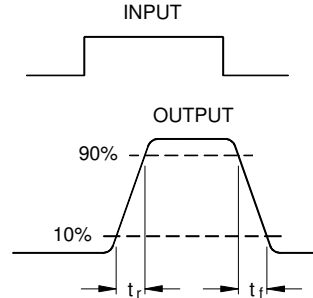

VOLTAGE WAVEFORM

- NOTES: 1. The input waveform is supplied by a generator with the following characteristics: $Z_{OUT} = 50 \Omega$, $t_r \leq 15 \text{ ns}$, Duty cycle $\approx 1\%$, $t_w = 100 \mu\text{s}$.
2. Waveforms are monitored on an oscilloscope with the following characteristics: $t_r \leq 12 \text{ ns}$, $R_{IN} \geq 1 \text{ M}\Omega$, $C_{IN} \leq 20 \text{ pF}$.

TYPICAL CHARACTERISTICS

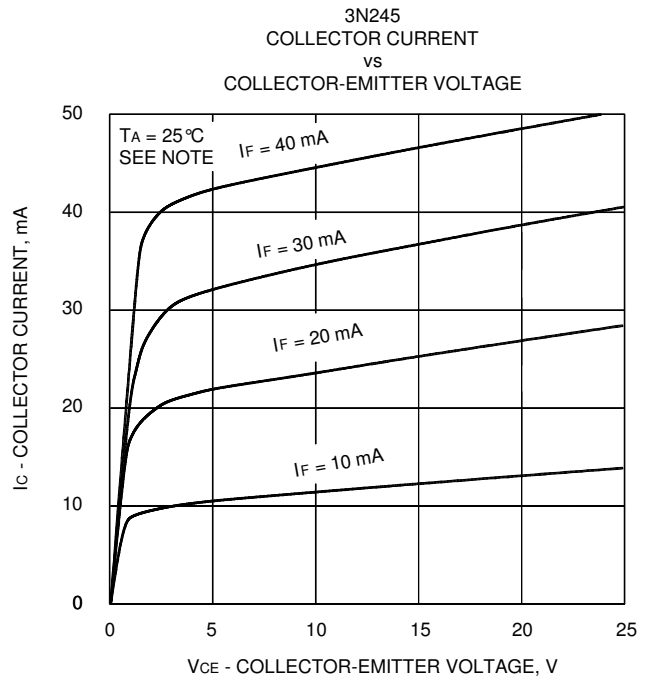
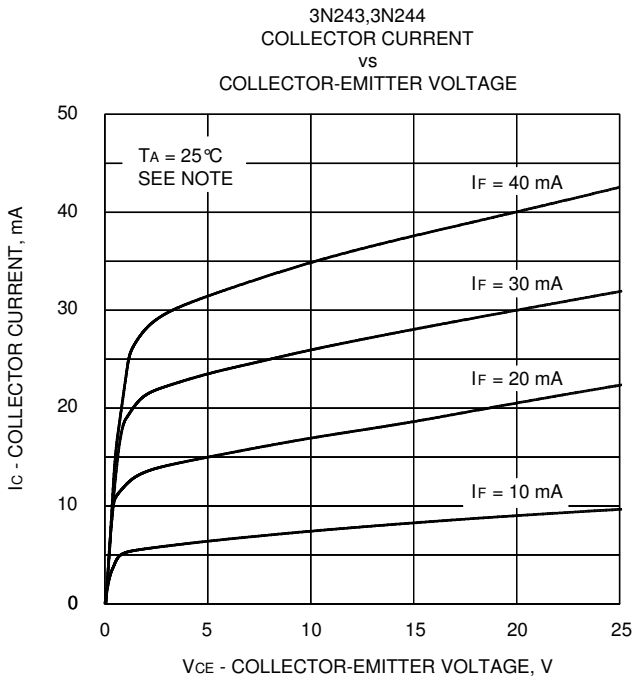

NOTE: This parameter was measured using pulse techniques. $T_w = 100 \mu\text{s}$, duty cycle = 1%.

05/29/03

TYPICAL CHARACTERISTICS (CONTINUED)

INPUT DIODE FORWARD CONDUCTION CHARACTERISTICS

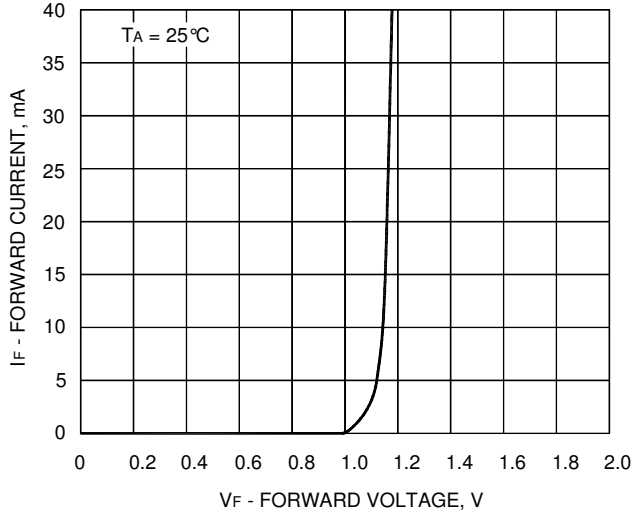

NORMALIZED ON STATE COLLECTOR CURRENT
 vs
 FREE-AIR TEMPERATURE

