

66292

GLOB TOP HIGH GAIN GULL WING OPTOCOUPLER



03/05/2007

Features:

- Glob Top Plastic Package
- SMT Mounting Gull Wing Package
- Proton Radiation tolerant
- +1500V electrical isolation

Applications:

- Eliminate ground loops
- Level shifting
- Line receiver
- Switching power supplies
- Motor control

DESCRIPTION

The **66292** contains a proton tolerant LED optically coupled to a corresponding high gain photon detector. This unique single channel Optocoupler provides high CTR and low leakage currents over the specified temperature range. The 66292 is in a surface mount Glob Top molded plastic Gull wing package. Separate pins for the photodiode and output stage enable TTL compatible saturation voltages with high speed operation.

ABSOLUTE MAXIMUM RATINGS

Input to Output Voltage	1500 V
Supply Voltage Vcc (see Note 1).....	0.5 to 20 V
Output Voltage Vo (see Note 1).....	0.5 to 20 V
Reverse Input Voltage	3 V
Input Diode Continuous Forward Current at (or below) 65°C Free-Air Temperature (see note 1)	60 mA
Peak Forward Input Current (1 ms duration)	100 mA
Output Current	60 mA
Output Power Dissipation at (or below) 25°C Free-Air Temperature (see Note 2)	150 mW
Storage Temperature	-40 °C to +125 °C
Operating Free-Air Temperature Range.....	-40 °C to +100 °C
Lead Solder Temperature (10 seconds max.)	240 °C

Notes:

1. Derate I_F at 0.05 mA/°C above 25 °C
2. Derate at 2.0 mW/ °C above +25 °C free-air temperature

Package Dimensions

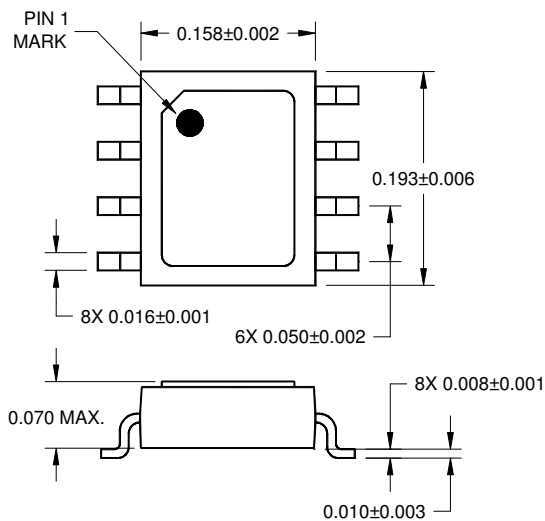

Schematic Diagram

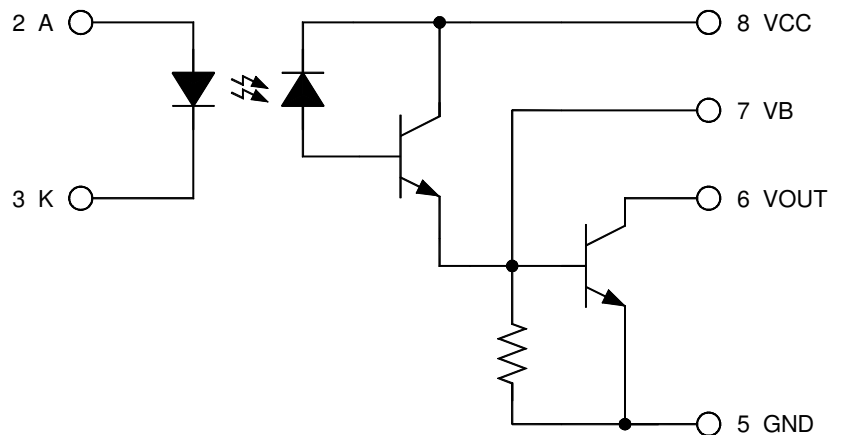

ELECTRICAL CHARACTERISTICST_A = -40°C to 100°C unless otherwise specified.

PARAMETER	SYMBOL	MIN	TYP	MAX	UNITS	TEST CONDITIONS
Current Transfer Ratio see (1)	CTR	300	1600		%	I _F = 1.6 mA, V _O = .4 V, V _{CC} = 4.5 V
Logic Low Output Voltage	V _{OL}		0.1 0.2	0.4 0.4	V V	I _F = 1.6 mA, I _{OL} = 1.5 mA, V _{CC} = 4.5 V I _F = 5.0 mA, I _{OL} = 10 mA, V _{CC} = 4.5 V
Logic High Output Current	I _{OH}		0.005	250	μA	I _F = 2 μA, V _O = V _{CC} = 18V
High Level Output Current	I _{CCH}		0.010	40	μA	I _F = 0 mA, V _{CC} = 18V
Low Level Supply Current	I _{CCL}			2.0	mA	I _F = 1.6 mA, V _{CC} = 18V
Input Forward Voltage	V _F		1.4	1.8	V	I _F = 1.6 mA
Input Reverse Breakdown Voltage	BV _R	3			V	I _R = 10 μA
Input-Output Insulation Leakage Current	I _{I-O}			1.0	μA	V _{I-O} = 1500 Vdc, Relative Humidity = 45%, t _A = 25°C, t = 5 s
Propagation Delay Time to High Output Level	t _{PLH}		5 4	60 30	μs μs	I _F = 1.6 mA, R _L = 4.7kΩ, V _{CC} = 5.0V I _F = 5 mA, R _L = 680kΩ, V _{CC} = 5.0V
Propagation Delay Time to Low Output Level	t _{PHL}		8 2	100 10	μs μs	I _F = 1.6 mA, R _L = 4.7kΩ, V _{CC} = 5.0V I _F = 5 mA, R _L = 680kΩ, V _{CC} = 5.0V
Input Capacitance	C _{IN}			60	pf	V _F = 0V, f = 1.0 MHz
Capacitance Input-Output	C _{I-O}			1.5	pf	f = 1.0 MHz, t _A = 25°C
Resistance (Input-Output)	R _{I-O}		10 ⁻¹²		Ω	V _{I-O} = 1500V, t _A = 25°C
Common Mode Transient Immunity at High Output Level	CM _H		1K		V/μs	V _{CM} = V _{pp} , V _{CC} = 5.0V, R _L = 1.5kΩ, I _F = 0 mA
Common Mode Transient Immunity at Low Output Level	CM _L		1K		V/μs	V _{CM} = V _{pp} , V _{CC} = 5.0V, R _L = 1.5kΩ, I _F = 1.6 mA

(1) DC current transfer ratio is defined as the ratio of output collector current I_O to the forward LED input current I_F times 100%**RECOMMENDED OPERATING CONDITIONS:**

PARAMETER	SYMBOL	MIN	MAX	UNITS
Input Current, Low Level	I _{FL}	0	1	μA
Input Current, High Level	I _{FH}	1.0	20	mA
Supply Voltage	V _{CE}	5	20	V
Operating Temperature	T _A	-40	100	°C

SELECTION GUIDE

PART NUMBER	PART DESCRIPTION
66292-001	Commercial
66292-101	- 40 to +100°C with 100% device screening