

**66126****SINGLE/DUAL CHANNEL, HERMETICALLY SEALED  
OPTOCOUPLER, SIMILAR TO 4N55**

08/31/2009

**Features:**

- 1500 Vdc isolation test voltage
- TTL and CMOS compatible
- 2 MHz bandwidth typical
- Faraday shield to provide high common mode rejection

**Applications:**

- Military and space
- Voltage level shifting
- Isolated receiver input
- Communication systems
- Medical systems

**DESCRIPTION**

The **66126** single/dual channel optocouplers utilize infrared LEDs optically coupled to high gain photo detectors. These unique optocouplers provide high switching speeds while providing high isolation (1500V min) over the full military temperature range (-55° to +125°C). The 66126 is available in standard and screened versions or tested to customer specifications.

**ABSOLUTE MAXIMUM RATINGS**

Peak Forward Input Current .....	40 mA (1ms duration)
Average Forward Input Current .....	20 mA
Input Power Dissipation (each channel) (Note 1) .....	36 mW
Reverse Input Voltage (each channel) .....	5 V
Supply voltage - $V_{CC}$ (each channel) (1 minute).....	7 V
Output Current - $I_O$ (each channel) .....	25 mA
Output Power Dissipation (each channel). (Note 2) .....	50 mW
Output Voltage - $V_O$ (each channel) .....	7 V
Base Current (Single Channel) .....	5 mA
Storage Temperature.....	-65°C to +150°C
Operating Free-Air Temperature Range .....	-55°C to +125°C
Lead Solder Temperature (10 seconds, 1/16" below seating plane).....	260°C

**Notes:**

1. Derate at 0.36 mW/°C above 25°C.
2. Derate at 0.5 mW/°C above 25°C.

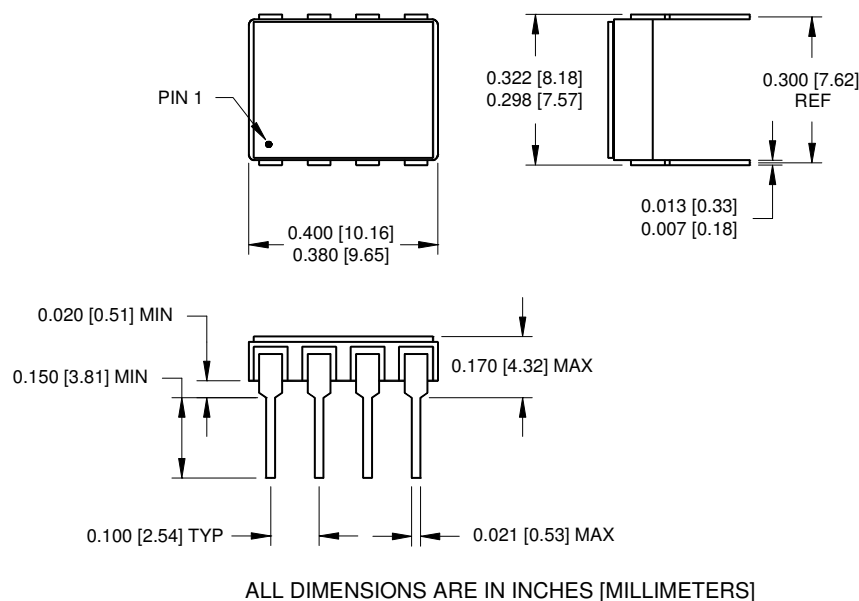
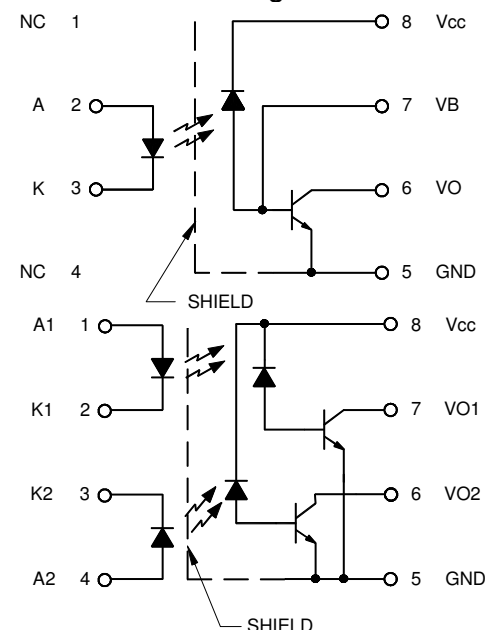
**Package Dimensions****Schematic Diagrams**

08/31/2009

**ELECTRICAL CHARACTERISTICS**T<sub>a</sub> = -55°C to 125°C unless otherwise specified.

PARAMETER	SYMBOL	MIN	TYP	MAX	UNITS	TEST CONDITIONS	NOTE
Current Transfer Ratio	CTR	9	20		%	I <sub>F</sub> = 16 mA, V <sub>O</sub> = 0.4 V, V <sub>CC</sub> = 4.5 V	1, 2
Output Leakage Current	I <sub>OH1</sub>		70	250	μA	I <sub>F</sub> = 250 μA, V <sub>CC</sub> = V <sub>O</sub> = 18 V I <sub>F</sub> (other channel) = 20 mA	1
Logic High Output Current	I <sub>OH</sub>		20	100	μA	I <sub>F</sub> = 250 μA, V <sub>CC</sub> = V <sub>O</sub> = 18 V I <sub>F</sub> (other channel) = 20 mA	1
High Level Output Current	I <sub>CCH</sub>		0.2	10	μA	I <sub>F</sub> = 0, V <sub>CC</sub> = 18 V I <sub>F</sub> (other channel) = 20 mA	1
Low Level Supply Current	I <sub>CCL</sub>		35	200	μA	I <sub>F1</sub> = I <sub>F2</sub> = 20 mA, V <sub>CC</sub> = 18 V	1
Input Forward Voltage	V <sub>F</sub>		1.5	1.8	V	I <sub>F</sub> = 20 mA	1
Input Reverse Breakdown Voltage	BV <sub>R</sub>	3			V	I <sub>R</sub> = 10 μA	1
Input-Output Insulation Leakage Current	I <sub>I-O</sub>			1.0	μA	V <sub>I-O</sub> = 1500 Vdc, Relative Humidity = 45% t <sub>A</sub> = 25°C, t = 5 s	4
Propagation Delay Time To High Output Level	t <sub>PLH</sub>		2	6	μs	I <sub>F</sub> = 16 mA, V <sub>CC</sub> = 5 V, R <sub>L</sub> = 8.2 kΩ C <sub>L</sub> = 50 pF	1
Propagation Delay Time To Low Output Level	t <sub>PHL</sub>		0.4	2	μs	I <sub>F</sub> = 16 mA, V <sub>CC</sub> = 5 V, R <sub>L</sub> = 8.2 kΩ C <sub>L</sub> = 50 pF	1

**TYPICAL CHARACTERISTICS**T<sub>a</sub> = 25°C, V<sub>CC</sub> = 5 V Each Channel

PARAMETER	SYMBOL	MIN	TYP	MAX	UNITS	TEST CONDITIONS	NOTE
Input Capacitance	C <sub>IN</sub>	60	120		pF	V <sub>F</sub> = 0, f = 1 MHz	1
Capacitance (Input-Output)	C <sub>I-O</sub>		1.5		pF	f = 1 MHz, V <sub>F</sub> = 0	1, 4
Capacitance (Input-Input) (Dual)	C <sub>I-I</sub>		0.55		pF	f = 1 MHz	3
Input Diode Temperature Coefficient	$\frac{\Delta V_F}{\Delta T_A}$		-1.8		mV/°C	I <sub>F</sub> = 18 mA	1
Resistance (Input-Output)	R <sub>I-O</sub>		10 <sup>12</sup>		Ω	V <sub>I-O</sub> = 500 Vdc	1
Input-Input Insulation Leakage Current (Dual)	I <sub>I-I</sub>		1		pA	Relative Humidity = 45% V <sub>I-I</sub> = 500 Vdc, t = 5 s	3
Common Mode Transient immunity at High Output Level	CM <sub>H</sub>	500	1000		V/μs	V <sub>CM</sub> = 50 V p-p, R <sub>L</sub> = 8.2 kΩ, I <sub>F</sub> = 0 mA	1, 5
Common Mode Transient Immunity at Low Output Level	CM <sub>L</sub>	500	1000		V/μs	V <sub>CM</sub> = 50 V p-p, R <sub>L</sub> = 8.2 kΩ, I <sub>F</sub> = 16 mA	1, 6

**NOTES:**

- Each channel.
- Current Transfer Ratio is defined as the ratio of output collector current, I<sub>O</sub>, to the forward LED input current, I<sub>F</sub>, times 100%.
- Measured between each input pair shorted together.
- Measured between input pins shorted together and the output pins shorted together.
- CM<sub>H</sub> is the maximum tolerable common mode transient to assure that the output will remain in a high logic state (i.e. V<sub>O</sub> > 2.0 V).
- CM<sub>L</sub> is the maximum tolerable common mode transient to assure that the output will remain in a low logic state (i.e. V<sub>O</sub> < 0.8 V).

**RECOMMENDED OPERATING CONDITIONS:**

PARAMETER	SYMBOL	MIN	MAX	UNITS
Input Current, Low Level	I <sub>FL</sub>	0	2	μA
Supply Voltage	V <sub>CC</sub>	2.0	18	V
Input Current, High Level	I <sub>FH</sub>	2.0	20	mA

**SELECTION GUIDE**

PART NUMBER	PART DESCRIPTION
66126-001	Single Channel, Mil Temperature (-55° to +125°C)
66126-011	Single Channel, Commercial
66126-101	Single Channel, Screened
66126-002	Dual Channel, Mil Temperature (-55° to +125°C)
66126-012	Dual Channel, Commercial
66126-102	Dual Channel, Screened