

**66058**

**SINGLE/DUAL CHANNEL, LOW-INPUT CURRENT,  
OPTOCOUPLER (Electrically similar to 6N140)**



09/23/03

**Features:**

- DSCC Approved 8978501PX (Dual) and 8981001PX (Single)
- High current transfer ratio: 1000% typical
- 1500 Vdc isolation test voltage
- Low input current requirement: 0.5mA

**Applications:**

- Telephone ring detection
- Voltage level shifting
- Isolated receiver input
- Communication systems
- Medical systems

**DESCRIPTION**

The **66058** is a single/dual optocoupler utilizes infrared LEDs optically coupled to high gain photodarlington detectors. This unique optocoupler provides high CTR and low leakage current over the full military temperature range (-55° to +125°C). The 66058 is an 8 pin dual-in-line, hermetically sealed package and is available in standard and screened versions or tested to customer specifications.

**ABSOLUTE MAXIMUM RATINGS**

Peak Forward Input Current (each channel) (1ms duration).....	20mA
Average Forward Input Current (each channel) (Note 1) .....	10mA
Reverse Input Voltage .....	5V
Output Current - I <sub>O</sub> (each channel) .....	40mA
Output Power Dissipation (each channel) (Note 2) .....	50mW
Supply Voltage - V <sub>CC</sub> (Note 3).....	0.5 to 20V
Output Voltage - V <sub>O</sub> (each channel) (Note 3) .....	-0.5 to 20V
Storage Temperature.....	-65°C to +150°C
Operating Free-Air Temperature Range.....	-55°C to +125°C
Lead Solder Temperature (10 seconds, 1/16" below seating plane).....	260°C

**Notes:**

1. Derate I<sub>F</sub> at 0.1 mA/°C above 25°C.
2. Collector output power plus one half of the total supply power is total output power. Derate at 0.5 mW/°C above 25°C.
3. The lowest total I<sub>OH</sub> over temperature is developed by keeping V<sub>CC</sub> as low as possible, but greater than 2 Volts. The most negative voltage at the detector side should be applied to Pin 5.

**Package Dimensions**

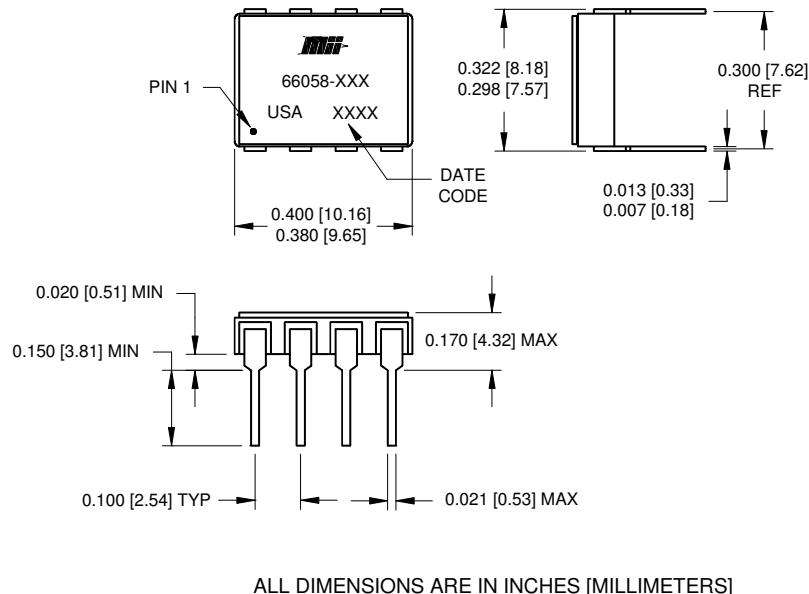

**Schematic Diagram**

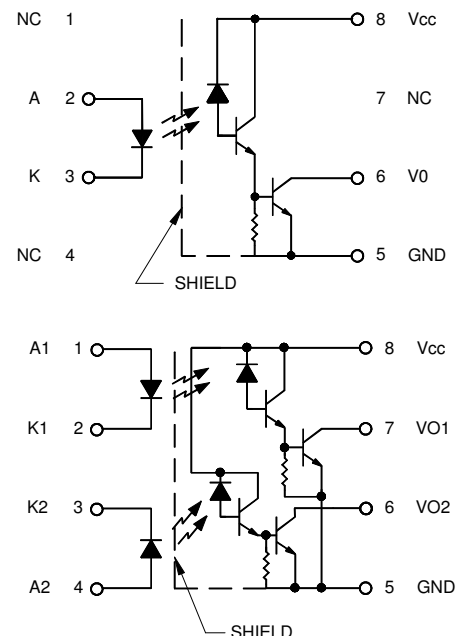

09/23/03

**ELECTRICAL CHARACTERISTICS**T<sub>a</sub> = -55°C to 125°C unless otherwise specified.

PARAMETER	SYMBOL	MIN	TYP	MAX	UNITS	TEST CONDITIONS	NOTE
Current Transfer Ratio	CTR	300	1000		%	I <sub>F</sub> = 0.5mA, V <sub>O</sub> = 0.4V, V <sub>CC</sub> = 4.5V	1,2
		300	750		%	I <sub>F</sub> = 1.6mA, V <sub>O</sub> = 0.4V, V <sub>CC</sub> = 4.5V	1,2
		200	400		%	I <sub>F</sub> = 5.0mA, V <sub>O</sub> = 0.4V, V <sub>CC</sub> = 4.5V	1,2
Logic Low Output Voltage	V <sub>OL</sub>		0.1	0.4	V	I <sub>F</sub> = 0.5mA, I <sub>OL</sub> = 1.5mA, V <sub>CC</sub> = 4.5V	1
			0.2	0.4	V	I <sub>F</sub> = 5.0mA, I <sub>OL</sub> = 10mA, V <sub>CC</sub> = 4.5V	
Logic High Output Current	I <sub>OH</sub>		.005	250	μA	I <sub>F</sub> = 2μA, V <sub>O</sub> = V <sub>CC</sub> = 18V	1,3
High Level Output Current	-XX1 -XX2	I <sub>CCH</sub>		10	μA	I <sub>F1</sub> = 0mA, V <sub>CC</sub> = 18V	
				20	μA	I <sub>F1</sub> = I <sub>F2</sub> = 0mA, V <sub>CC</sub> = 18V	
Low Level Supply Current	-XX1 -XX2	I <sub>CCL</sub>		2	mA	I <sub>F1</sub> = 1.6mA, V <sub>CC</sub> = 18V	
				4	mA	I <sub>F1</sub> = I <sub>F2</sub> = 1.6mA, V <sub>CC</sub> = 18V	
Input Forward Voltage	V <sub>F</sub>		1.4	1.7	V	I <sub>F</sub> = 1.6mA	1
Input Reverse Breakdown Voltage	BV <sub>R</sub>	5			V	I <sub>R</sub> = 10μA	1
Input-Output Insulation Leakage Current	I <sub>I-O</sub>			1.0	μA	V <sub>I-O</sub> = 1500Vdc, Relative Humidity = 45% t <sub>A</sub> = 25°C, t = 5s	4
Propagation Delay Time To High Output Level	t <sub>PLH</sub>		17	60	μs	I <sub>F</sub> = 0.5mA, V <sub>CC</sub> = 5.0V, R <sub>L</sub> = 4.7kΩ	
			14	50	μs	I <sub>F</sub> = 1.6mA, V <sub>CC</sub> = 5.0V, R <sub>L</sub> = 1.5kΩ	
			8	30	μs	I <sub>F</sub> = 5mA, V <sub>CC</sub> = 5.0V, R <sub>L</sub> = 680Ω	
Propagation Delay Time To Low Output Level	t <sub>PHL</sub>		30	100	μs	I <sub>F</sub> = 0.5mA, V <sub>CC</sub> = 5.0V, R <sub>L</sub> = 4.7kΩ	
			3	30	μs	I <sub>F</sub> = 1.6mA, V <sub>CC</sub> = 5.0V, R <sub>L</sub> = 1.5kΩ	
			2	10	μs	I <sub>F</sub> = 5mA, V <sub>CC</sub> = 5.0V, R <sub>L</sub> = 680Ω	

**TYPICAL CHARACTERISTICS**T<sub>a</sub> = 25°C, V<sub>CC</sub> = 5V Each Channel

PARAMETER	SYMBOL	MIN	TYP	MAX	UNITS	TEST CONDITIONS	NOTE
Input Capacitance	C <sub>IN</sub>		60		pF	V <sub>F</sub> = 0, f = MHz, t <sub>a</sub> = 25°C	1
Capacitance (Input-Output)	C <sub>I-O</sub>		1.5		pF	f = 1MHz, t <sub>a</sub> = 25°C	1, 5
Input Diode Temperature Coefficient	$\frac{\Delta V_F}{\Delta T_A}$		-1.8		mV/°C	I <sub>F</sub> = 1.6mA	1
Resistance (Input-Output)	R <sub>I-O</sub>		10 <sup>12</sup>		Ω	V <sub>I-O</sub> = 500V, t <sub>a</sub> = 25°C	1, 5
Resistance (Input-Input)	R <sub>I-I</sub>		10 <sup>12</sup>		Ω	V <sub>I-I</sub> = 500V, t <sub>a</sub> = 25°C	6
Input-Input Insulation Leakage Current	I <sub>I-I</sub>		0.5		nA	Relative Humidity = 45% V <sub>I-I</sub> = 500V, t = 5s	6
Common Mode Transient immunity at High Output Level	CM <sub>H</sub>	500	1000		V/μs	V <sub>CM</sub> = 50V P-P, V <sub>CC</sub> = 5.0V, R <sub>L</sub> = 1.5kΩ, I <sub>F</sub> = 0mA, t <sub>a</sub> = 25°C	7,9
Common Mode Transient Immunity at Low Output Level	CM <sub>L</sub>	500	1000		V/μs	V <sub>CM</sub> = 50V P-P, V <sub>CC</sub> = 5.0V, R <sub>L</sub> = 1.5kΩ, I <sub>F</sub> = 1.6mA, t <sub>a</sub> = 25°C	8,9

**NOTES:**

- Each channel.
- CURRENT TRANSFER RATIO is defined as the ratio of output collector current, I<sub>O</sub>, to the forward LED input current, I<sub>F</sub>, times 100%.
- I<sub>F</sub> = 2μA for channel under test. For all other channels, I<sub>F</sub> = 10mA.
- Device considered a two-terminal device.
- Measured between each input pair shorted together and all output pins shorted together.
- Measured between each input pair shorted together.
- CM<sub>H</sub> is the maximum tolerable common mode transient to assure that the output will remain in a high logic state (i.e. V<sub>O</sub> > 2.0V).
- CM<sub>L</sub> is the maximum tolerable common mode transient to assure that the output will remain in a low logic state (i.e. V<sub>O</sub> < 0.8V).
- In applications where dV/dt may exceed 50,000 V/μs (such as static discharge) a series resistor, R<sub>CC</sub>, should be included to protect the detector IC's from destructively high surge currents. The recommended value is  $R_{CC} = \frac{1V}{0.60 I_F(mA)} k\Omega$ .

**RECOMMENDED OPERATING CONDITIONS:**

PARAMETER	SYMBOL	MIN	MAX	UNITS
Input Current, Low Level	I <sub>FL</sub>	0	2	μA
Input Current, High Level	I <sub>FH</sub>	0.5	5	mA
Supply Voltage	V <sub>CC</sub>	2.0	18	V

**66058**

09/23/03

**SINGLE/DUAL CHANNEL, LOW-INPUT CURRENT OPTOCOUPLER (Electrically similar to 6N140)**

**SELECTION GUIDE**

<b>PART NUMBER</b>	<b>PART DESCRIPTION</b>
66058-001	Single Channel, Military
66058-002	Dual Channel, Military
66058-012	Dual Channel, Commercial
66058-101	Single Channel, Screened
66058-102	Dual Channel, Screened
66058-103	Single Channel, 5962-89785 01PX
66058-105	Dual Channel, 5962-89810 01PX