

**66173**

**GULL WING HERMETICALLY SEALED  
DUAL CHANNEL OPTOCOUPLER  
(Electrically Similar To 6N134)**



01/23/2007

**Features:**

- 5 MHz bandwidth typical
- 1000 Vdc isolation test voltage
- TTL compatible input and output
- High radiation immunity
- Faraday shield to provide high common mode rejection

**Applications:**

- Military and Space
- High reliability systems
- Voltage Level Shifting
- Isolated Receiver Input
- Communication systems
- Medical systems

**DESCRIPTION**

The **66173** dual channel optocoupler consists of two LEDs optically coupled to two high speed, high gain inverting detector gates. Maximum isolation can be achieved while providing TTL outputs capable of switching with propagation delays of 65ns typical. The 66173 is a 10 pin gull wing hermetically sealed package and is available in standard and screened versions or tested to customer specifications.

**ABSOLUTE MAXIMUM RATINGS**

Peak Forward Input Current (each channel) (1 ms duration).....	40 mA
Average Forward Input Current (each channel).....	20 mA
Input Power Dissipation (each channel).....	35 mW
Reverse Input Voltage (each channel).....	5 V
Supply Voltage (1-minute maximum).....	7 V
Output Current - I <sub>O</sub> (each channel).....	25 mA
Output Power Dissipation (each channel).....	40 mW
Output Voltage - V <sub>O</sub> (each channel).....	7 V
Total Power Dissipation.....	350 mW
Storage Temperature.....	-65°C to +150°C
Operating Free-Air Temperature Range.....	-55°C to +125°C
Lead Solder Temperature (10 seconds, 1/16" from case).....	260°C

**Package Dimensions**

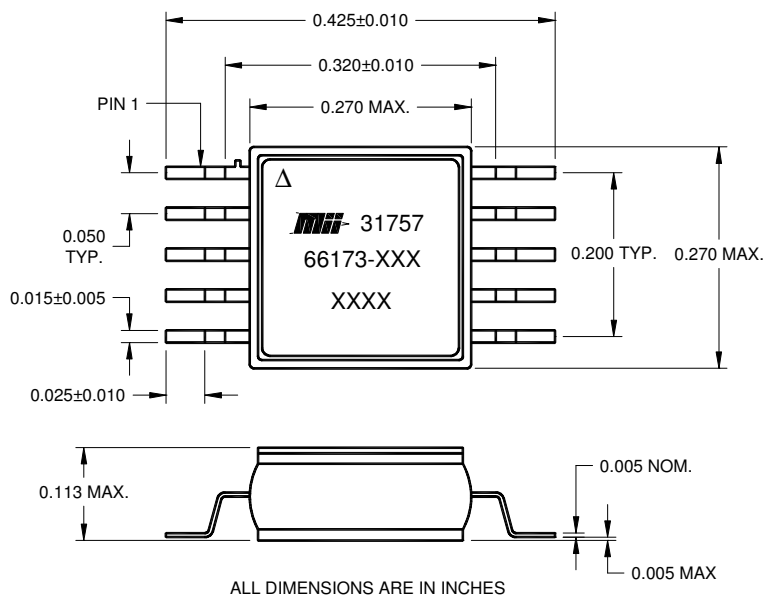

**Schematic Diagram**

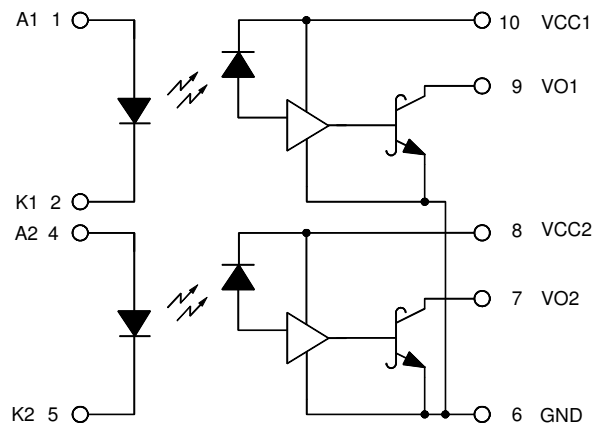

NOTE: 0.01 TO 0.1 μF BYPASS CAPACITOR MUST BE CONNECTED BETWEEN PINS 6 AND 8, 6 AND 10.

66173

## GULL WING HERMETICALLY SEALED DUAL CHANNEL OPTOCOUPLER (Electrically Similar to 6N134)

01/23/2007

**ELECTRICAL CHARACTERISTICS**  $T_a = -55^\circ\text{C TO AT } 125^\circ\text{C}$  unless otherwise specified.

PARAMETER	SYMBOL	MIN	TYP	MAX	UNITS	TEST CONDITIONS	NOTE
High Level Output Current	$I_{OH}$		20	250	$\mu\text{A}$	$V_{CC} = 5.5\text{ V}$ , $V_O = 5.5\text{ V}$ , $I_F = 250\ \mu\text{A}$	1, 9
Low Level Output Voltage	$V_{OL}$		0.35	0.6	V	$V_{CC} = 5.5\text{ V}$ , $I_F = 10\text{ mA}$ $I_{OL}$ (Sinking) = 10 mA	1
High Level Supply Current	$I_{CCH}$		18	28	mA	$V_{CC} = 5.5\text{ V}$ , $I_F = 0$ (Both Channels)	
Low Level Supply Current	$I_{CCL}$		26	36	mA	$V_{CC} = 5.5\text{ V}$ , $I_F = 20\text{ mA}$ (Both Channels)	
Input Forward Voltage	$V_F$		1.5	1.8	V	$I_F = 20\text{ mA}$	1
Input Reverse Breakdown Voltage	$BV_R$	5			V	$I_R = 10\ \mu\text{A}$	
Input-Output Insulation Leakage Current	$I_{I-O}$			1.0	$\mu\text{A}$	$V_{I-O} = 1500\text{ Vdc}$ , Relative Humidity = 45% $T_a = 25^\circ\text{C}$ , $t = 5\text{ s}$	2
Propagation Delay Time To High Output Level	$t_{PLH}$		65	100	ns	$R_L = 510\ \Omega$ , $C_L = 15\text{ pF}$ $I_F = 13\text{ mA}$ , $T_a = 25^\circ\text{C}$	5
Propagation Delay Time To Low Output Level	$t_{PHL}$		55	100	ns	$R_L = 510\ \Omega$ , $C_L = 15\text{ pF}$ $I_F = 13\text{ mA}$ , $T_a = 25^\circ\text{C}$	6

**TYPICAL CHARACTERISTICS**  $T_a = 25^\circ\text{C}$ ,  $V_{CC} = 5\text{ V}$  each channel

PARAMETER	SYMBOL	MIN	TYP	UNITS	TEST CONDITIONS	NOTE
Input Capacitance	$C_{IN}$		60	pF	$V_F = 0$ , $f = 1\text{ MHz}$	1
Input Diode Temperature Coefficient	$\frac{\Delta V_F}{\Delta T_a}$		-1.9	mV/ $^\circ\text{C}$	$I_F = 20\text{ mA}$	1
Resistance (Input-Output)	$R_{I-O}$		$10^{12}$	$\Omega$	$V_{I-O} = 500\text{ V}$	3
Capacitance (Input-Output)	$C_{I-O}$		1.7	pF	$f = 1\text{ MHz}$	3
Input-Input Insulation Leakage Current	$I_{I-I}$		0.5	nA	Relative Humidity = 45% $V_{I-I} = 500\text{ V}$ , $t = 5\text{ s}$	4
Resistance (Input-Input)	$R_{I-I}$		$10^{12}$	$\Omega$	$V_{I-I} = 500\text{ V}$	4
Capacitance (Input-Input)	$C_{I-I}$		0.80	pF	$f = 1\text{ MHz}$	4
Output Rise-Fall Time (10-90%)	$t_r$ , $t_f$		35	ns	$R_L = 510\ \Omega$ , $C_L = 15\text{ pF}$ $I_F = 13\text{ mA}$	
Common Mode Transient Immunity at High Output Level	$CM_H$	1000	10000	V/ $\mu\text{s}$	$V_{CM} = 10\text{ V (peak)}$ , $V_O$ (min) = 2 V, $R_L = 510\ \Omega$ , $I_F = 0\text{ mA}$	7
Common Mode Transient Immunity at Low Output Level	$CM_L$	1000	10000	V/ $\mu\text{s}$	$V_{CM} = 10\text{ V (peak)}$ , $V_O$ (max) = 0.8 V, $R_L = 510\ \Omega$ , $I_F = 10\text{ mA}$	8

**NOTES:**

- Each channel
- Measured between pins 1 through 5 shorted together and pins 6 through 10 shorted together.
- Measured between pins 1 and 2 or 4 and 5 shorted together, and pins 6 through 10 shorted together.
- Measured between pins 1 and 2 shorted together, and pins 4 and 5 shorted together.
- The  $t_{plh}$  propagation delay is measured from the 6.5mA point on the trailing edge of the input pulse to the 1.5V point on the trailing edge of the output pulse.
- The  $t_{phl}$  propagation delay is measured from the 6.5mA point on the leading edge of the input pulse to the 1.5V point on the leading edge of the output pulse.
- $CM_H$  is the max. tolerable common mode transient to assure that the output will remain in a high logic state (i.e.  $V_o > 2.0\text{ V}$ ).
- $CM_L$  is the max. tolerable common mode transient to assure that the output will remain in a low logic state (i.e.  $V_o < 0.8\text{ V}$ ).
- It is essential that a bypass capacitor (0.01 to 0.1  $\mu\text{F}$  ceramic) be connected from pin 6 to pin 10.

**RECOMMENDED OPERATING CONDITIONS**

PARAMETER	SYMBOL	MIN	MAX	UNITS
Input Current, Low Level Each Channel	$I_{FL}$	0	100	$\mu\text{A}$
Input Current, High Level Each Channel	$I_{FH}$	12.5	20	mA
Supply Voltage	$V_C$	4.5	5.5	V
Fan Out (TTL Load) Each Channel	N		6	
Operating Temperature	$T_a$	-55	125	$^\circ\text{C}$

**SELECTION GUIDE**

PART NUMBER	PART DESCRIPTION
66173-000	Screened
66173-002	-55 $^\circ$ to +125 $^\circ\text{C}$
66173-003	Commercial (0 $^\circ$ to 70 $^\circ\text{C}$ )
66173-004	-40 $^\circ$ to +85 $^\circ\text{C}$