

66183 PROTON RADIATION TOLERANT 6 PIN LCC OPTOCOUPLER



03/11/2009

Features:

- High Reliability
- Base lead provided for conventional transistor biasing
- Rugged package
- Stability over wide temperature
- +1000V electrical isolation
- JANS Level screening available

Applications:

- Eliminate ground loops
- Level shifting
- Line receiver
- Switching power supplies
- Motor control

DESCRIPTION

The **66183** is a single channel device electrically similar to the 4N49. This product has been designed to be more tolerant to proton radiation. The 66183 optocoupler is packaged in a hermetically sealed 6 pin leadless chip carrier (LCC). This device can be supplied to customer specifications as well as tested in accordance with MIL-PRF-19500 to Class S level.

ABSOLUTE MAXIMUM RATINGS

Input to Output Isolation Voltage	1 kV
Input Diode Continuous Forward Current	40 mA
Peak Forward Input Current (value applies for $t_w \leq 10\mu s$, PRR < 300 pps)	1 A
Reverse Input Voltage	2 V
Input Power Dissipation (Note 1)	80 mW
Emitter-Base Voltage	7 V
Collector-Emitter Voltage (Value applies to emitter-base open-circuited and the input diode equal to zero).....	60 V
Collector-Base Voltage	60 V
Continuous Collector Current	50 mA
Continuous Transistor Power Dissipation (Note 2)	300 mW
Storage Temperature.....	-65°C to +150°C
Operating Free-Air Temperature Range	-55°C to +125°C
Lead Solder Temperature (10 seconds max.).....	240°C

Notes:

1. Derate linearly at the rate of 1.33 mW/°C above 65°C case.
2. Derate linearly at the rate of 3 mW/°C above 25°C case.

Package Dimensions

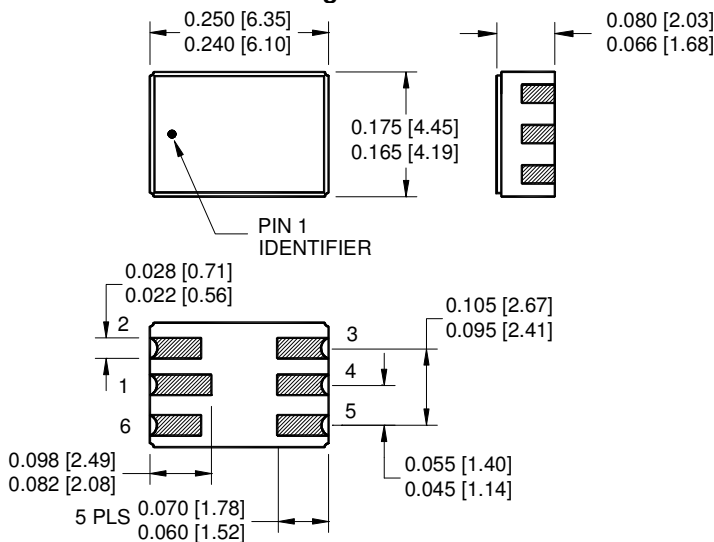

Schematic Diagram

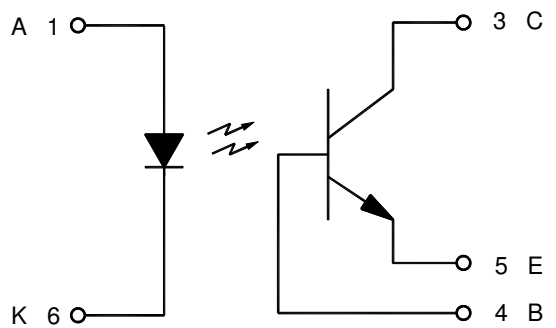

ALL DIMENSIONS ARE IN INCHES [MILLIMETERS]

03/11/2009

ELECTRICAL CHARACTERISTICS $T_A = 25^\circ\text{C}$ unless otherwise specified.

PARAMETER	SYMBOL	MIN	TYP	MAX	UNITS	TEST CONDITIONS	NOTE
Input Diode Static Reverse Current	I_R			10	μA	$V_R = 2\text{ V}$	
Input Diode Static Forward Voltage -55°C	V_F	1.0		2.2	V	$I_F = 10\text{ mA}$	
Input Diode Static Forward Voltage $+25^\circ\text{C}$	V_F	0.8	1.8	2.0	V	$I_F = 10\text{ mA}$	
Input Diode Static Forward Voltage $+100^\circ\text{C}$	V_F	0.8		2.2	V	$I_F = 10\text{ mA}$	

OUTPUT TRANSISTOR $T_A = 25^\circ\text{C}$ unless otherwise specified.

PARAMETER	SYMBOL	MIN	TYP	MAX	UNITS	TEST CONDITIONS	NOTE
Collector-Base Breakdown Voltage	$V_{(BR)CBO}$	45			V	$I_C = 100\ \mu\text{A}, I_B = 0, I_F = 0$	
Collector-Emitter Breakdown Voltage	$V_{(BR)CEO}$	40			V	$I_C = 1\text{ mA}, I_B = 0, I_F = 0$	
Emitter-Base Breakdown Voltage	$V_{(BR)EBO}$	7			V	$I_C = 0\text{ mA}, I_E = 100\ \mu\text{A}, I_F = 0$	
Off-State Collector Current $+100^\circ\text{C}$	I_{CEO}			100 100	nA μA	$V_{CE} = 20\text{ V}, I_F = 0\text{ mA}, I_B = 0$	

COUPLED CHARACTERISTICS $T_A = 25^\circ\text{C}$ unless otherwise specified.

PARAMETER	SYMBOL	MIN	TYP	MAX	UNITS	TEST CONDITIONS	NOTE
On State Collector Current	$I_{C(ON)}$	2.0			mA	$V_{CE} = 5\text{ V}, I_F = 1\text{ mA}, I_B = 0$	
On State Collector Current $+100^\circ\text{C}$	$I_{C(ON)}$	2.0			mA	$V_{CE} = 5.0\text{ V}, I_F = 2\text{ mA}, I_B = 0$	
On State Collector Current -55°C	$I_{C(ON)}$	2.8			mA	$V_{CE} = 5\text{ V}, I_F = 2\text{ mA}, I_B = 0$	
Collector-Emitter Saturation Voltage	$V_{CE(SAT)}$			0.3	V	$I_F = 2\text{ mA}, I_C = 2\text{ mA}$	
Input to Output Isolation Voltage	V_{I-O}	1000			V	$I_{I-O} = 100\text{ nA}$	1
Input to Output Capacitance	C_{IO}		2.5	5	pF	$f = 1\text{ MHz}, V_{I-O} = 1000\text{ V}$	1
Rise Time-Phototransistor Operation	t_r		10	25	μs	$V_{CC} = 10\text{ V}, I_F = 10\text{ mA}, R_L = 100\ \Omega, I_B = 0$	2
Fall Time-Phototransistor Operation	t_f		10	25	μs	$V_{CC} = 10\text{ V}, I_F = 10\text{ mA}, R_L = 100\ \Omega, I_B = 0$	2

NOTES:

- These parameters are measured between all phototransistor leads shorted together and with both input diode leads shorted together.
- This parameter must be measured using pulse techniques ($t_W = 100\ \mu\text{s}$ duty cycle $\leq 1\%$).

RECOMMENDED OPERATING CONDITIONS:

PARAMETER	SYMBOL	MIN	MAX	UNITS
Input Current, Low Level	I_{FL}	0	90	μA
Input Current, High Level	I_{FH}	2	10	mA
Supply Voltage	V_{CE}	5	10	V
Operating Temperature	T_A	-55	100	$^\circ\text{C}$

SELECTION GUIDE

PART NUMBER	PART DESCRIPTION
66183-001	Commercial
66183-101	Screened to JAN level
66183-103	Screened to JANTX level
66183-105	Screened to JANTXV level
66183-300	Screened to JANS level