

**66012****FOUR CHANNEL, HERMETICALLY SEALED, LOW-INPUT CURRENT, 6N140 OPTOCOUPLER**

12/01/2006

**Features:**

- DSCC Approved 8302401EX
- High current transfer ratio: 1000% typical
- 1500 Vdc isolation test voltage
- Low input current requirement: 0.5 mA
- Faraday Shield to provide high Common Mode Rejection

**Applications:**

- Military and Space
- High reliability systems
- Voltage Level Shifting
- Isolated Receiver Input
- Communication systems

**DESCRIPTION**

The **66012** optocoupler contains four infrared LEDs optically coupled to four corresponding high gain photon detectors. This unique quad optocoupler provides high CTR and low leakage currents over the full military temperature range (-55° to +125°C). The 66012 is a 16 pin dual-in-line, hermetically sealed package and is available in standard and MIL-PRF-38534 screened versions or tested to customer specifications.

**ABSOLUTE MAXIMUM RATINGS**

Peak Forward Input Current (each channel) (1ms duration).....	20 mA
Average Forward Input Current (each channel).....(Note 1).....	10 mA
Reverse Input Voltage .....	5 V
Output Current - $I_O$ (each channel) .....	40 mA
Output Power Dissipation (each channel) .....	50 mW
Supply Voltage - $V_{CC}$ .....	-0.5 to 20 V
Output Voltage - $V_O$ (each channel).....(Note 3).....	-0.5 to 20 V
Operating Free-Air Temperature Range.....	-55°C to +125°C
Storage Temperature.....	-65°C to +150°C
Lead Solder Temperature (10 second max, 1/16" below seating plane).....	260°C

**Notes:**

1. Derate  $I_F$  at 0.10 mA/°C above 25°C.
2. Collector output power plus one fourth of the total supply power is total output power. Derate at 0.5mW/°C above 25°C.
3. The lowest total  $I_{OH}$  over temperature is developed by keeping  $V_{CC}$  as low as possible, but greater than 2 Volts. The most negative voltage at the detector side should be applied to Pin 10.

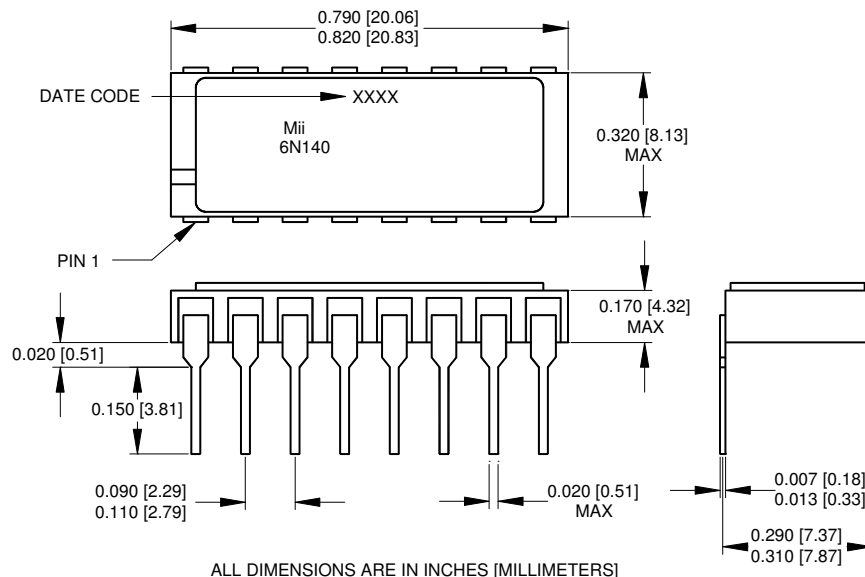
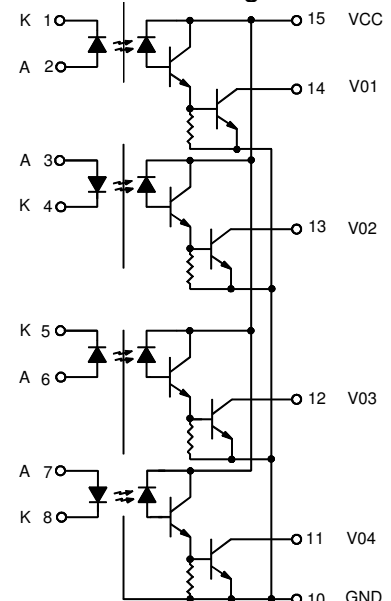
**Package Dimensions****Schematic Diagram**

66012

FOUR CHANNEL, HERMETICALLY SEALED, LOW-INPUT CURRENT, 6N140 OPTOCOUPLER

12/01/2006

ELECTRICAL CHARACTERISTICS

T<sub>a</sub> = -55°C to 125°C unless otherwise specified.

PARAMETER	SYMBOL	MIN	TYP	MAX	UNITS	TEST CONDITIONS	NOTE
Current Transfer Ratio	CTR	300	1000		%	I <sub>F</sub> = 0.5 mA, V <sub>O</sub> = 0.4 V, V <sub>CC</sub> = 4.5 V	1, 2
		300	750		%	I <sub>F</sub> = 1.6 mA, V <sub>O</sub> = 0.4 V, V <sub>CC</sub> = 4.5 V	1, 2
		200	400		%	I <sub>F</sub> = 5.0 mA, V <sub>O</sub> = 0.4 V, V <sub>CC</sub> = 4.5 V	1, 2
Logic Low Output Voltage	V <sub>OL</sub>		0.1	0.4	V	I <sub>F</sub> = 0.5 mA, I <sub>OL</sub> = 1.5 mA, V <sub>CC</sub> = 4.5 V	1
			0.2	0.4	V	I <sub>F</sub> = 5.0 mA, I <sub>OL</sub> = 10 mA, V <sub>CC</sub> = 4.5 V	
Logic High Output Current	I <sub>OH</sub>		.005	250	μA	I <sub>F</sub> = 2 μA, V <sub>O</sub> = V <sub>CC</sub> = 18 V	1, 3
High Level Output Current	I <sub>CCH</sub>		.010	40	μA	I <sub>F1</sub> = I <sub>F2</sub> = I <sub>F3</sub> = I <sub>F4</sub> = 0 mA, V <sub>CC</sub> = 18 V	
Low Level Supply Current	I <sub>CCL</sub>		2	4	mA	I <sub>F1</sub> = I <sub>F2</sub> = I <sub>F3</sub> = I <sub>F4</sub> = 1.6 mA, V <sub>CC</sub> = 18 V	
Input Forward Voltage	V <sub>F</sub>		1.4	1.8	V	I <sub>F</sub> = 1.6 mA	1
Input Reverse Breakdown Voltage	BV <sub>R</sub>	5			V	I <sub>R</sub> = 10 μA	1
Input-Output Insulation Leakage Current	I <sub>I-O</sub>			1.0	μA	V <sub>I-O</sub> = 1500 Vdc, Relative Humidity = 45% t <sub>A</sub> = 25°C, t = 5 s	4
Propagation Delay Time To High Output Level	t <sub>PLH</sub>			60	μs	I <sub>F</sub> = 0.5 mA, V <sub>CC</sub> = 5.0 V, R <sub>L</sub> = 4.7 kΩ	
				30	μs	I <sub>F</sub> = 5 mA, V <sub>CC</sub> = 5.0 V, R <sub>L</sub> = 680 kΩ	
Propagation Delay Time To Low Output Level	t <sub>PHL</sub>			100	μs	I <sub>F</sub> = 0.5 mA, V <sub>CC</sub> = 5.0 V, R <sub>L</sub> = 4.7 kΩ	
				10	μs	I <sub>F</sub> = 5 mA, V <sub>CC</sub> = 5.0 V, R <sub>L</sub> = 680 kΩ	

TYPICAL CHARACTERISTICS T<sub>a</sub> = 25°C, V<sub>CC</sub> = 5V Each Channel

PARAMETER	SYMBOL	MIN	TYP	MAX	UNITS	TEST CONDITIONS	NOTE
Input Capacitance	C <sub>IN</sub>		60		pF	V <sub>F</sub> = 0, f = 1 MHz, t <sub>a</sub> = 25°C	1
Capacitance (Input-Output)	C <sub>I-O</sub>		1.5		pF	f = 1 MHz, t <sub>a</sub> = 25°C	1, 5
Input Diode Temperature Coefficient	$\frac{\Delta V_F}{\Delta T_A}$		-1.8		mV/°C	I <sub>F</sub> = 1.6 mA	1
Resistance (Input-Output)	R <sub>I-O</sub>		10 <sup>12</sup>		Ω	V <sub>I-O</sub> = 500 V, t <sub>a</sub> = 25°C	1, 5
Resistance (Input-Input)	R <sub>I-I</sub>		10 <sup>12</sup>		Ω	V <sub>I-I</sub> = 500 V, t <sub>a</sub> = 25°C	6
Input-Input Insulation Leakage Current	I <sub>I-I</sub>		0.5		nA	Relative Humidity = 45% V <sub>I-I</sub> = 500 V, t = 5 s	6
Common Mode Transient immunity at High Output Level	CM <sub>H</sub>	500	1000		V/μs	V <sub>CM</sub> = 50 V <sub>P-P</sub> , V <sub>CC</sub> = 5.0 V, R <sub>L</sub> = 1.5kΩ, I <sub>F</sub> = 0 mA	7,9
Common Mode Transient Immunity at Low Output Level	CM <sub>L</sub>	500	1000		V/μs	V <sub>CM</sub> = 50 V <sub>P-P</sub> , V <sub>CC</sub> = 5.0 V, R <sub>L</sub> = 1.5 kΩ, I <sub>F</sub> = 1.6 mA	8,9

NOTES:

- Each channel.
- CURRENT TRANSFER RATIO is defined as the ratio of output collector current, I<sub>O</sub>, to the forward LED input current, I<sub>F</sub>, times 100%.
- I<sub>F</sub> = 2 μA for channel under test. For all other channels, I<sub>F</sub> = 10 mA.
- Device considered a two-terminal device. Pins 1-8 are shorted together and pins 9-16 are shorted together.
- Measured between each input pair shorted together and all output pins for that channel shorted together.
- Measured between adjacent pairs shorted together, i.e. between pins 1 and 2 shorted together and pins 3 and 4 shorted together, etc.
- CM<sub>H</sub> is the maximum tolerable common mode transient to assure that the output will remain in a high logic state (ie. V<sub>O</sub> > 2.0 V).
- CM<sub>L</sub> is the maximum tolerable common mode transient to assure that the output will remain in a low logic state (ie. V<sub>O</sub> < 0.8 V).
- In applications where dv/dt may exceed 50,000 V/μs (such as static discharge) a series resistor, R<sub>CC</sub>, should be included to protect the detector ICs from destructively high surge currents. The recommended value is R<sub>CC</sub> =  $\frac{1V}{0.6I_F}$  = kΩ

RECOMMENDED OPERATING CONDITIONS:

PARAMETER	SYMBOL	MIN	MAX	UNITS
Input Current, Low Level	I <sub>FL</sub>	0	2	μA
Input Current, High Level	I <sub>FH</sub>	0.5	5	mA
Supply Voltage	V <sub>CC</sub>	2.0	18	V

SELECTION GUIDE

PART NUMBER	PART DESCRIPTION
66012-001	DSCC Dwg 8302401EX
66012-002	Commercial, military temperature range (-55°C to +125°C)
66012-003	Commercial (0° to +70°C)