

# 66219 FIBEROPTIC TRANSMITTER IN ST HOUSING



06/15/2012

### Features:

- Fiberoptic LED with internal ball lens
- Industry standard ST style connector
- High coupled output power 25  $\mu$ W @100 mA (100 micron fiber) typical
- Data rates up to 10 MHz
- 850 nm wavelength

### Applications:

- Short haul data Link
- Mobile Communications
- Local Area Networks

### DESCRIPTION

The **66219** series, high speed fiber-optic LED is packaged in an industry standard ST housing. An internal "glass ball" lens focuses the light from the die to increase light coupling for 50 to 150 micron multi-mode optical fibers. Typical coupled power is greater than -17 dbm (20  $\mu$ W) into a 100 micron fiber at 100 mA. With rise and fall times of 10 ns maximum, this part may be used in medium to high speed data transmission applications. This LED may be screened to meet specific customer requirements or to MIL-PRF-19500.

### ABSOLUTE MAXIMUM RATINGS

Forward Voltage .....	2 Vdc
Forward Continuous Current (Note 1).....	100 mA
Transmission Rate at 100 mA I <sub>F</sub> .....	10 Mbits/s
Storage Temperature.....	-55°C to +150°C
Operating Temperature .....	-40°C to +125°C
Soldering Temperature (10 seconds, 1/16" from case).....	240°C

### NOTES:

1. Derate linearly at 1mA/°C above 25°C.

### Package Dimensions

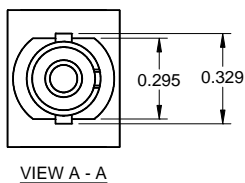
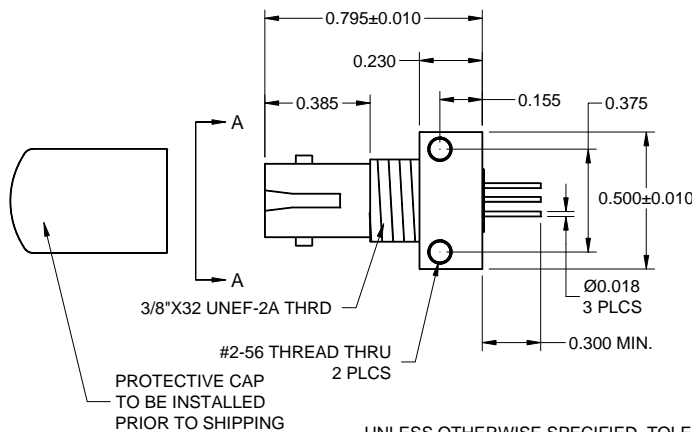

### Schematic Diagram

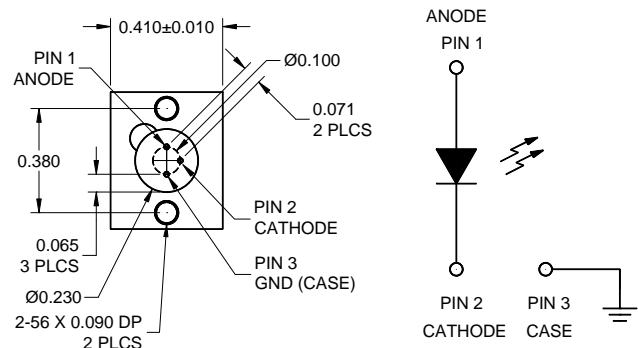

# 66219

# FIBEROPTIC TRANSMITTER IN ST HOUSING

06/15/2012

## ELECTRICAL CHARACTERISTICS

T<sub>A</sub> = 25°C unless otherwise specified.

PARAMETER		SYMBOL	MIN	TYP	MAX	UNITS	TEST CONDITIONS	NOTE
Forward Voltage		V <sub>F</sub>		1.7	2.0	V	I <sub>F</sub> = 100 mA	
Reverse Breakdown Voltage		BV <sub>R</sub>	1.0	5.0		V	I <sub>R</sub> = 10 μA	
Coupled Power Output		P <sub>o</sub>	20		40	μW	I <sub>F</sub> = 7.5 mA, 200 μm fiber	
Response Time	10-90%	T <sub>RES</sub>		3	6	ns	1 V pre-bias, 100 mA peak	
	90-10%			4	6	ns		
Peak Wavelength		λ <sub>p</sub>		850		ns	I <sub>F</sub> = 100 mA	

### RECOMMENDED OPERATING CONDITIONS:

PARAMETER	SYMBOL	MIN	MAX	UNITS
Forward Current	I <sub>F</sub>	20	100	mA
Transmission Rate		10		Mb/sec

### SELECTION GUIDE

PART NUMBER	PART DESCRIPTION
66219-001	Commercial
66219-101	Screened