

62000

GaAs LIGHT EMITTING DIODE "PILL PACK"



05/29/03

Features:

- Hermetically sealed
- High output, 940nm
- Small package
- PC board mountable
- Narrow beam angle

Applications

- Incremental encoding
- Reflective sensors
- Position sensors
- Level sensors

DESCRIPTION

The **62000** is a GaAs Infrared Light Emitting Diode in a lensed "pill" package designed to be mounted in a double-clad printed circuit board. It is well matched to companion phototransistors and photodarlingtonts with it's narrow beam angle lens and small size which make it ideal for use in optical encoders, card reader arrays, etc. where maximum power out is not a consideration. Available binned to customer specifications and/or screened to MIL-PRF-19500.

ABSOLUTE MAXIMUM RATINGS

Storage Temperature.....	-65°C to +150°C
Operating Temperature.....	-55°C to +125°C
Reverse Voltage	3Vdc
Forward Current-Continuous (at 25°C case) (see note 1)	100mA
Soldering Temperature (10 second)	240°C

NOTE: 1. Derate linearity to 125°C case at the rate of 1mA/°C above 25°C.

Package Dimensions

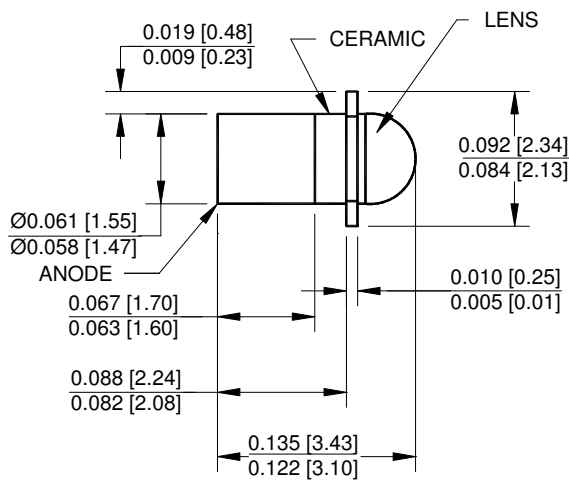

ALL DIMENSIONS ARE IN INCHES [MILLIMETERS]

Schematic Diagram

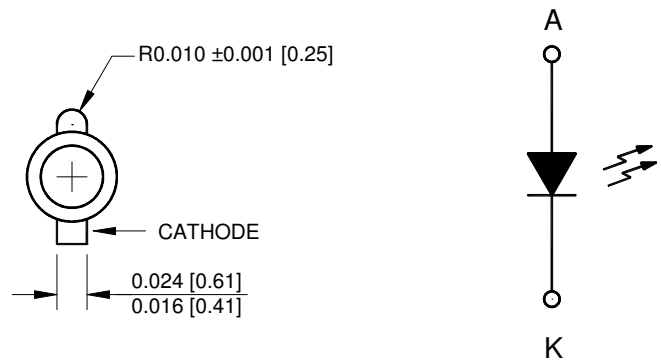

62000

05/29/03

ELECTRICAL CHARACTERISTICS

T_A = 25°C unless otherwise specified.

GaAs LIGHT-EMITTING DIODE "PILL PACK"

PARAMETER	SYMBOL	MIN	TYP	MAX	UNITS	TEST CONDITIONS	NOTE
Output Power	62000-X01 62000-X02 62000-X03 62000-X04	0.25 0.40 1.0 1.5			mW	I _F = 50mA	
Forward Voltage	62000-X0X			1.6	V	I _F = 50mA	
Reverse Breakdown Voltage	62000-X0X	3			V	I _R = 10μA	
Radiation Rise Time	62000-X0X		0.7		μs		
Peak Wavelength	62000-X0X		940		nm	I _F = 50mA	
Beam Angle	62000-X0X		20		degrees		

INSTANTANEOUS POWER OUTPUT versus FORWARD CURRENT

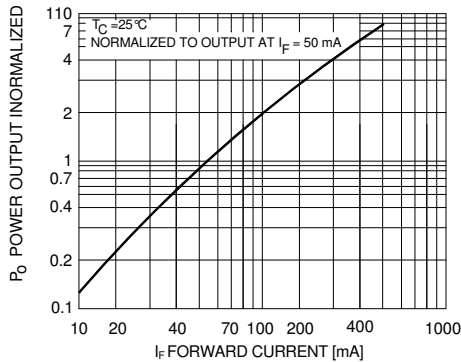

RADIATION PATTERN

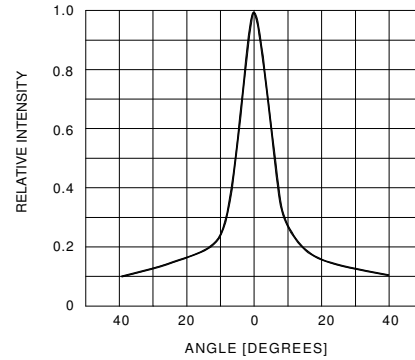

POWER OUTPUT versus JUNCTION TEMPERATURE

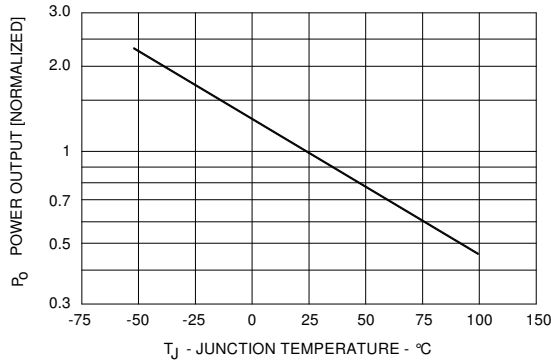

RELATIVE SPECTRAL OUTPUT

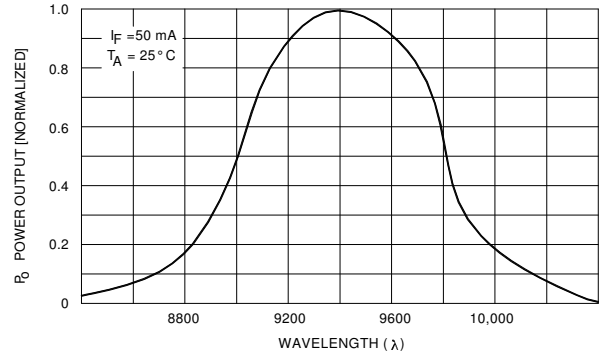

SELECTION GUIDE

PART NUMBER	PART DESCRIPTION	P _O (min)
62000-001	Commercial	0.25 mW
62000-101	Screened	0.25 mW
62000-002	Commercial	0.4 mW
62000-102	Screened	0.4 mW
62000-003	Commercial	1 mW
62000-103	Screened	1 mW
62000-004	Commercial	1.5 mW
62000-104	Screened	1.5 mW