

62074

FIBER OPTIC LIGHT EMITTING DIODE



08/28/03

Features:

- Hermetically Sealed
- High Radiant Output for Fiber Optic Applications
- High Speed

Applications:

- Computer Peripheral Link
- Tempest Applications
- Mobile Communications
- Local Area Networks

DESCRIPTION

The **62074** Light Emitting Diodes are designed to interface with multimode fibers from 50/125 to 200/230 microns. These LED's convert electrical current into optical power that can be used in fiber optic communication. This series provides high irradiance and is mounted on a TO-46 header with metal protective cap. Available binned to customer specifications and/or screened to MIL-PRF-19500.

ABSOLUTE MAXIMUM RATINGS 25°C FREE AIR TEMPERATURE UNLESS NOTED

Reverse Voltage(at 25°C case temperature)	1Vdc
Forward Current-Continuous.....(Note 1)	100mA
Transmission Rate at 100mA I _F	10Mbits/s
Storage Temperature	-55°C to +150°C
Operating Temperature	-40°C to +125°C
Soldering Temperature (10 seconds, 1/16 inch from case).....	240°C

NOTES:

1. Derate linearly to 125°C free-air temperature at the rate of 1.0 mA/°C.

Package Dimensions

Schematic Diagram

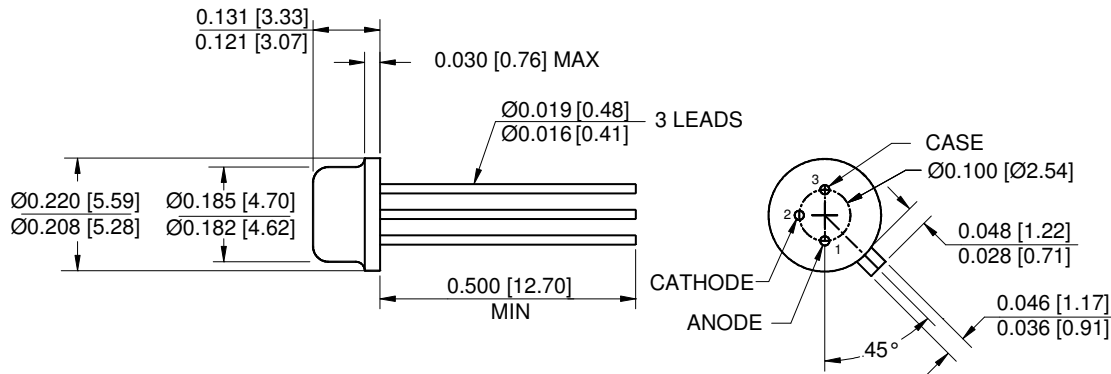

ALL DIMENSIONS ARE IN INCHES [MILLIMETERS]

62074

0/28/03

FIBER OPTIC LIGHT EMITTING DIODE

ELECTRICAL CHARACTERISTICS

T_A = 25°C unless otherwise specified.

PARAMETER	SYMBOL	MIN	TYP	MAX	UNITS	TEST CONDITIONS	NOTE	
Output Power	62074-X01 62074-X02	P _O	2.5	7.5		mW	I _F = 100mA	
Coupled Power Out	62074-XX1 62074-X02	P _{OC}	150	50		μW	I _F = 100mA	1
Forward Voltage	62074-XXX	V _F		2.0		V	I _F = 100mA	
Reverse Breakdown Voltage	62074-XXX	B _{VR}	1			V	I _R = 10μA	
Radiation Rise/Fall Time	62074-XXX	t _R		10		ns	I _F = 100mA Prebias @ 5 mA	
Peak Wavelength	62074-XXX	λ _P		850		nm	I _F = 50mA	

NOTES:

1. Tested using a 100/140μm fiber. Actual coupled power may vary due to alignment procedures and/or receptable and fiber tolerances.

RECOMMENDED OPERATING CONDITIONS:

PARAMETER	SYMBOL	MIN	MAX	UNITS
Forward Current	I _F	1	100	mA
Transmission Rate		10		Mbits/S

SELECTION GUIDE

PART NUMBER	PART DESCRIPTION	P _O Range, MAX
62074-001	Commercial	150μW
62074-101	(-55°C to +125°C) 100% Screened	150μW
62074-002	Commercial	50μW
62074-102	(-55°C to +125°C) 100% Screened	50μW