

# 65035 HIGH RELIABILITY BACK BIASED HALL EFFECT STUD, SWITCHING OUTPUT WITH CABLE



11/30/06

### Features:

- Wide operating temperature range -55 °C to +150°C
- High magnetic sensitivity
- Wide operating voltage range 18 to 32 V
- Chopper stabilized amplifier minimizes amplifier offset resulting in improved temperature stability
- MIL-STD-202 and MIL-STD-461E Qualified

### Applications:

- Proximity sensing of Ferrous targets
- Gear tooth sensing
- Speed sensing
- Angular Position sensing
- Linear Position Sensing

### DESCRIPTION

The 65035 Hall effect stud sensor detects the presence of a ferrous material and provides a switched output. The sensor switches LOW in the presence of a ferrous target and switches HIGH when the target is removed. The sensor is built into a threaded stainless steel tube and contains a single element Hall effect IC with an integral Samarium Cobalt magnet and pole piece to optimize sensor performance. Additional circuitry is added to expand the operating supply voltage range and provide surge protection against outside induced transients.

### ABSOLUTE MAXIMUM RATINGS

Supply Voltage Range.....	18.0 V to 32.0 V
Supply Current (Fault) .....	30 mA.
Power Dissipation, @ T <sub>A</sub> = 25°C (P <sub>D</sub> ).....	100 mW
Output Current (Fault) .....	20 mA
Storage Temperature.....	-65°C to +150°C
Operating Free-Air Temperature Range.....	-55°C to +150°C

### Package Dimensions

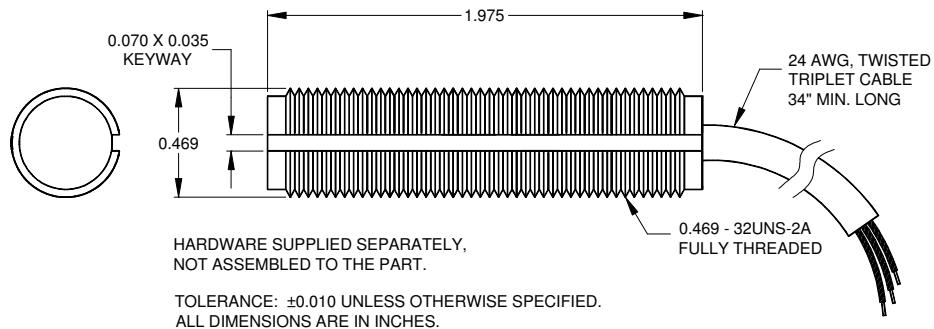

### Schematic Diagram

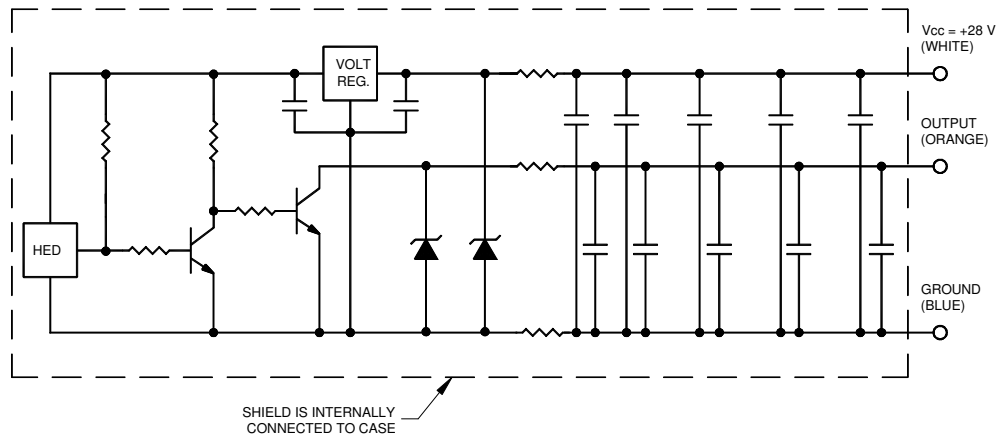

# 65035 HIGH RELIABILITY BACK BIASED HALL EFFECT STUD, SWITCHING OUTPUT WITH CABLE

11/30/06

## ELECTRICAL CHARACTERISTICS

T<sub>A</sub> = 25°C unless otherwise specified.

PARAMETER	SYMBOL	MIN	TYP	MAX	UNITS	TEST CONDITIONS
Supply Voltage	V <sub>CC</sub>	18.0		32.0	V	Continuous Operating
Supply Current	I <sub>CC</sub>			30	mA	V <sub>CC</sub> = 28.0 V
Output Saturation Voltage	V <sub>OL</sub>		0.9	1.0	V	V <sub>CC</sub> = 28 V, I <sub>OL</sub> = 20 mA
Output Leakage Current	I <sub>OH</sub>			100	μA	V <sub>CC</sub> = 28 V, Output High
Power on Response Time	t <sub>ON</sub>			20	ms	V <sub>CC</sub> > 18 V

## MAGNETIC CHARACTERISTICS

T<sub>A</sub> = 25°C

PARAMETER	SYMBOL	MIN	TYP	MAX	UNITS	TEST CONDITIONS
Δ Field Change for Sensing	Δ B	120			G	Target Present to Removed
Operating Air Gap	AG	0.25 0.01		2.03 0.080	mm in	Output Switching
Polarity	P		Low High			Ferrous Target Present Ferrous Target Removed

### NOTES:

1. Operating Air Gap is dependant on magnetic properties of target. A high grade A2 steel target was used for datasheet characterization. A high end magnet incorporated into the target can increase operating Air Gap by a factor of 5 or more.

## Qualified to the following requirements:

### Environmental

- MIL-STD-202 METHOD 105C Altitude, Test Condition B
- MIL-STD-202 METHOD 214A Random Vibration, 3 Hrs/Axis
- 3 Impact Shocks, 6 Orthogonal Axis Mechanical Shock, 20 G's for 11 seconds
- MIL-STD-202 METHOD 103B Humidity, Condition B, 96 Hours
- MIL-STD-202 METHOD 109C Explosive Atmosphere
- MIL-STD-202 METHOD 110A Sand and Dust
- ASTM G85.A4 Salt Spray, SO<sub>2</sub>, 336 Hours
- MIL-STD-202 METHOD 112 Helium Leak Test, < 1 X 10<sup>-6</sup> Torr, Condition D
- MIL-STD-202 METHOD 107G Thermal Shock, -65°C to +125°C

### EMI / EMC

- MIL-STD-461E RS103 Radiated Susceptability, 200 V/m (30 MHz to 18 GHz)
- MIL-STD-461E CS114 Conducted Susceptability, Limit Curve 5
- MIL-STD-461E CS115 Conducted Susceptability, I<sub>MAX</sub> 5 A
- MIL-STD-461E CS116 Conducted Susceptability, I<sub>MAX</sub> 10 A

### Lightning Strike

- RTCA DO-160 Section 22, Waveform A Induced Indirect Differential Transient, 70 V or 5 A

TYPICAL SWITCHING POINT GRAPH

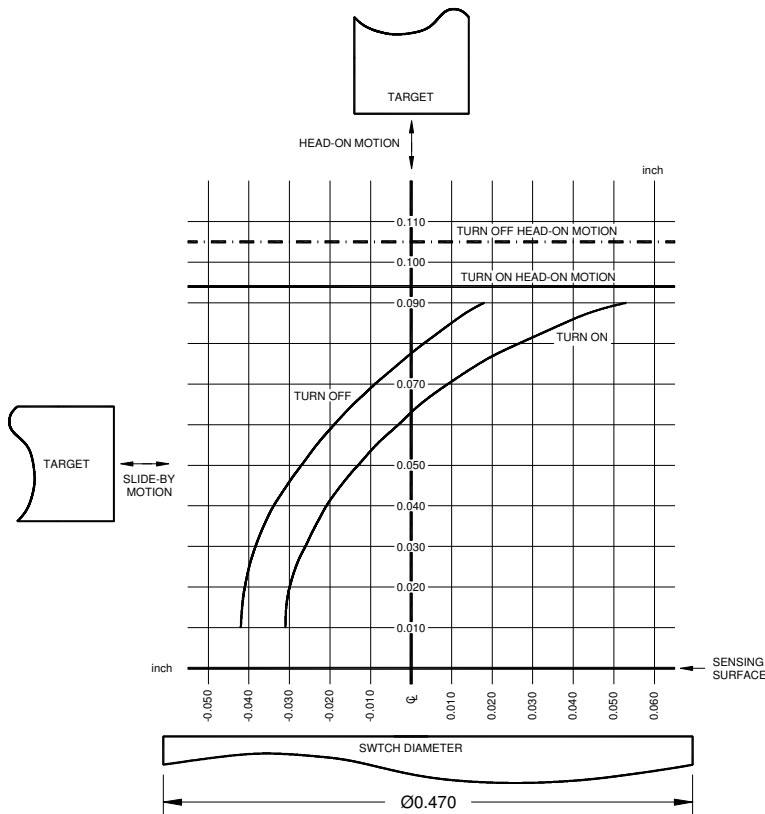

ORDERING INFORMATION:

PART NUMBER	DESCRIPTION
65035-001	Commercial
65035-101	Screened