

67023 4N53 RED HERMETIC, OVER RANGE DISPLAY



05/26/2009

Features:

- Conforms to MIL-PRF-19500/708
- Categorized for luminous intensity

Applications:

- High reliability systems
- Instrumentation panels
- Communication equipment
- Medical equipment
- Harsh environments

DESCRIPTION

The **4N53** is a solid state over range display for use in high reliability applications. The display is hermetically sealed and conforms to MIL-PRF-19500/708, the general specification for light emitting diode displays. The character height is 0.290" (7.37mm).

The 4N53 is an over range device which displays "±1" and a right-hand decimal point. The display is typically driven using external switching transistors.

ABSOLUTE MAXIMUM RATINGS

Forward Current, each LED.....	10 mA
Reverse Voltage, each LED.....	4 V
Storage Temperature.....	-65 °C to +125 °C
Operating Free-Air Temperature Range.....	-55 °C to +100 °C
Lead Solder Temperature (5 seconds, 1/16" below seating plane).....	260 °C

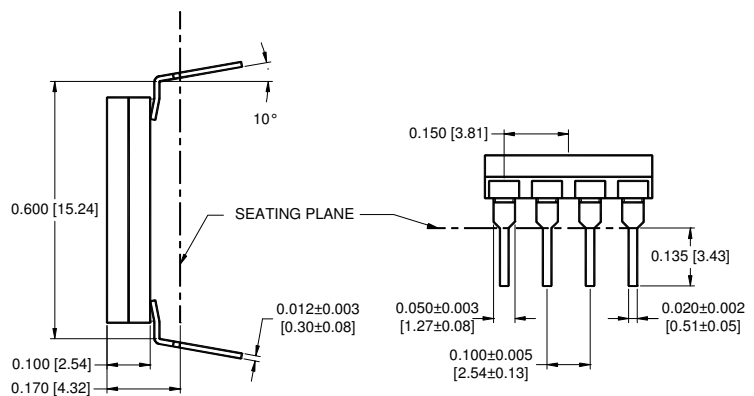
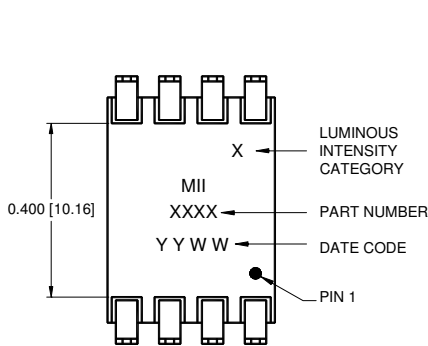
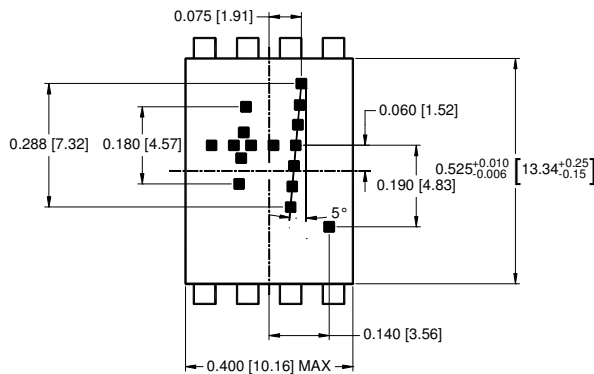

ALL TOLERANCES ARE ± 0.015 UNLESS OTHERWISE SPECIFIED
ALL DIMENSIONS ARE IN INCHES [MILLIMETERS].

ELECTRICAL OPTICAL CHARACTERISTICS

T_A = -55°C to +100°C unless otherwise specified.

PARAMETER	SYMBOL	MIN	TYP	MAX	UNITS	TEST CONDITIONS	NOTE
Power Dissipation	P _T		280	320	mW	V _{CC} = 5.5V	1
Luminous Intensity per LED	I _V	44	85		μcd	I _F = 10 mA, T _A = 25°C	
Forward Voltage per LED	V _F		1.6	2.0	V	I _F = 10 mA	
Leak Rate				5x10 ⁻⁸		cc/sec	
Wavelength at Peak Emission	λ _P		655		nm	T _A = 25°C	
Dominant Wavelength	d		640			T _A = 25°C	2
Weight			1		gm		

NOTES:

- I_F = 10mA, all diodes lit.
- The dominant wavelength, λ_d is a single wavelength that defines the saturated color of monochromatic light, as derived from the CIE chromaticity diagram.

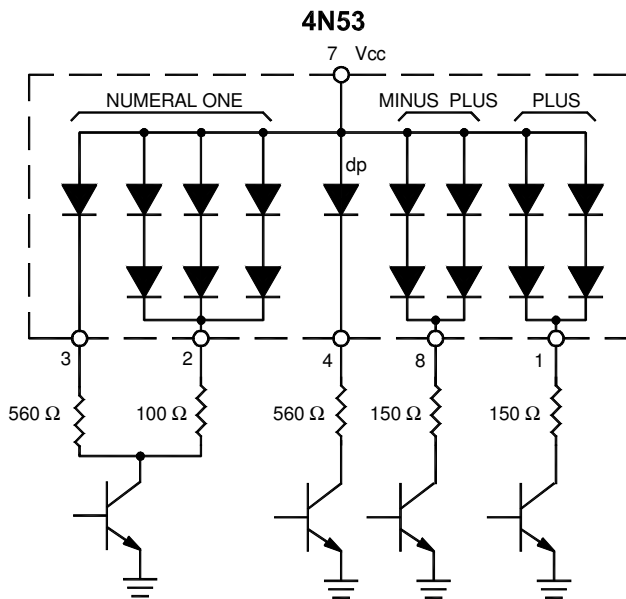

TYPICAL DRIVE CIRCUIT: V_{CC} = 5.0 VOLTS

TERMINAL CONNECTIONS

PIN	FUNCTION
1	Plus
2	Numeral One
3	Numeral One
4	Decimal Point
5	Open
6	Open
7	Vcc
8	Minus/Plus

TRUTH TABLE

CHARACTER	PIN			
	1	2,3	4	8
+	H	X	X	H
-	L	X	X	H
1	X	H	X	X
DECIMAL POINT	X	X	H	X
BLANK	L	L	L	L

- NOTES:**
 L = LED DRIVER transistor - OFF
 H = LED DRIVER transistor - ON
 X = Don't Care.

RECOMMENDED OPERATING CONDITIONS:

PARAMETER	SYMBOL	MIN	MAX	UNITS
Operating Temperature	T _A	-55	100	°C
Forward Current	I _F	5	10	mA

SELECTION GUIDE

PART NUMBER	PART DESCRIPTION
67023-003	4N53 Commercial
67023-013	JAN4N53XX
67023-103	JANTX4N53XX

Luminous intensity code

LUMINOUS INTENSITY CODE	MINIMUM LUMINOUS INTENSITY	MAXIMUM LUMINOUS INTENSITY
	μcd	μcd
D	59	106
E	79	142
F	106	190
G	142	255
H	190	342
I	257	462
J	343	617
K	457	820

The first X in the DSCC Part number is intensity code. Where a luminous intensity code is required, it must be specified in the contract or order. (Due to the overlapping of the luminous intensity codes, it is recommended that the two adjacent categories be specified).

The second X in the DSCC Part number is the lead finish code.

FINISH LETTER	LEAD FINISH
A	Hot solder dip
C	Gold plate