

52150/52175
78HGA REPLACEMENT

**POSITIVE ADJUSTABLE 5-AMP
VOLTAGE REGULATOR**

Mii

MICROPAC

MICROCIRCUITS PRODUCTS
DIVISION

Features:

- Replacement for 78HGA
- 5.0 A Output Current
- Internal Current And Thermal Limiting
- Internal Short Circuit Current Limit
- Low Drop-Out Voltage (Typically 2.3 V @ 5.0 A)
- 50W Power Dissipation
- Electrically Isolated Case
- Steel TO-3 Case

Applications:

- Designed for use in general purpose applications where adjustability is advantageous.
- Military and Hi Rel Industrial applications where hermeticity is required.

ORDER INFORMATION

52150 Standard
52175 MIL-STD-883 Screened

DESCRIPTION

The 52150/52175, which is a replacement for the 78HGA, is an adjustable 4-terminal positive voltage regulator capable of supplying in excess of 5.0 A over a 5.0 V to 24 V output range. Only two external resistors are required to set the output voltage. It is packaged in a hermetically sealed TO-3, and provides 50W power dissipation. The regulator consists of a monolithic chip driving a discrete series-pass element. A beryllium-oxide substrate is used in conjunction with an isothermal layout to optimize the thermal characteristics of each device and still maintain electrical isolation between the various chips. This unique circuit design limits the maximum junction temperature of the power output transistor to provide full automatic thermal overload protection. If the safe operating area is ever exceeded (Note 1), the device simply shuts down rather than fail or damage other system components. This feature eliminates the need to design costly regulators built from discrete components.

ABSOLUTE MAXIMUM RATINGS

Input Voltage.....	40 V
Internal Power Dissipation @T _c = 25°C.....	50W
Maximum Input-to-Output Voltage Differential	35 V
Operating Junction Temperature	150°C
Storage Temperature Range	-55°C to +150°C
Pin Temperature (Soldering, 60 seconds).....	300°C
Commercial Temperature Range 52150	0°C to +125°C
Military Temperature Range 52175	-55°C to +125°C

Micropac Industries cannot assume any responsibility for any circuits shown or represent that they are free from patent infringement. Micropac reserves the right to make changes at any time in order to improve design and to supply the best product possible.

ELECTRICAL CHARACTERISTICS

$T_J = 25^\circ\text{C}$, $V_{IN} = 10\text{ V}$ and $I_{OUT} = -2.0\text{A}$ unless otherwise specified

PARAMETER	SYMBOL	TEST CONDITIONS	MIN	TYP	MAX	UNIT
Output Voltage (Note 4)	V_{OUT}	$I_{OUT} = 2.0\text{A}$, $V_{IN} = V_{OUT} + 3.5\text{V}$	5.0		24	V
Line Regulation (Note 2)	ΔV_{OUT}	$V_{IN} = 7.5\text{ to }25\text{V}$		0.2%	1%	V
Load Regulation (Note 2)	ΔV_{OUT}	$10\text{mA} \leq I_{OUT} \leq 5.0\text{A}$		0.2%	1%	V
Quiescent Current	I_Q	$I_{OUT} = 0$		3.4	10	mA
Ripple Rejection	RR	$I_{OUT} = 1.0\text{A}$, $f = 210\text{Hz}$, $5.0\text{V}_{\text{pk-pk}}$	60			dB
Output Noise	V_n	$10\text{Hz} \leq f \leq 100\text{ kHz}$ $V_{IN} = V_{OUT} + 5.0\text{V}$		50		μV_{RMS}
Dropout Voltage (Note 5)	V_{DD}	$I_{OUT} = 5.0\text{A}$		2.3	2.5	V
		$I_{OUT} = 3.0\text{A}$		2.0	2.3	V
Short-Circuit Current Limit	I_{OS}	$V_{IN} = 15\text{V}$, $V_{OUT} = 5\text{V}$		7.0	12.0	A
Control Pin Voltage	V_C		4.85	5.0	5.25	V

NOTES:

1. This voltage regulator offers output transistor safe-area protection. However, to maintain full protection, the device must be operated within the maximum input-to-output voltage differential rating listed on the data sheet under "Absolute Maximum Ratings". For applications violating these limits, device will not be fully protected.
2. Load and line regulation are specified at constant junction temperature. Pulse testing is required with a pulse width $\leq 1\text{ ms}$ and a duty cycle $\leq 5\%$. Full Kelvin connection methods must be used to measure these parameters.
3. The performance characteristics of the adjustable series (78HGA) is specified for $V_{OUT} = 5.0\text{ V}$, unless otherwise noted.
4. V_{OUT} is defined as $V_{OUT} = \frac{R1 + R2}{R2} (V_{CONT})$ where R1 and R2 are defined in the Basic Test Circuit diagram.
5. Dropout Voltage is the input-output voltage differential that causes the output voltage to decrease by 5% of its initial value.

Micropac Industries cannot assume any responsibility for any circuits shown or represent that they are free from patent infringement. Micropac reserves the right to make changes at any time in order to improve design and to supply the best product possible.

DESIGN CONSIDERATIONS

This device has thermal overload protection from excessive power and internal short circuit protection which limits the circuit's maximum current. Thus, the device is protected from overload abnormalities. Although the internal power dissipation is limited, the junction temperature must be kept below the maximum specified temperature (150°C). It is recommended by the manufacturer that the maximum junction temperature be kept as low as possible for increased reliability. To calculate the maximum junction temperature or heat sink required, the following thermal resistance values should be used.

Package	Type	Max
	θ_{JC}	θ_{JC}
TO-3	1.8	2.5

Where: T_J = Junction Temperature
 T_A = Ambient Temperature

P_D = Power Dissipation θ_{CS} = Case-to-heat sink thermal resistance
 θ_{JC} = Junction-to-case thermal resistance θ_{SA} = Heat sink-to-ambient thermal resistance

$$P_{D(MAX)} = \frac{T_{J(max)} - T_A}{\theta_{JC} + \theta_{CA}} \quad \theta_{CA} = \theta_{CS} + \theta_{SA}$$

$$\text{Solving for } T_J = T_A + P_D (\theta_{JC} + \theta_{CA})$$

θ_{CA} = Case-to-ambient thermal resistance

The device is designed to operate without external compensation components. However, the amount of external filtering of these voltage regulators depends upon the circuit layout. If in a specific application the regulator is more than four inches from the filter capacitor, a 2 μ F solid tantalum capacitor should be used at the input. A 1 μ F capacitor should be used at the output to reduce transients created by fast switching loads, as seen in the basic test circuit. These filter capacitors must be located as close to the regulator as possible.

Caution: Permanent damage can result from forcing the output voltage higher than the input voltage. A protection diode from output to input should be used if this condition exists.

VOLTAGE OUTPUT

The device has an adjustable output voltage from 5.0V to 24V which can be programmed by the external resistor network (potentiometer or two fixed resistors) using the relationship:

$$V_{OUT} = V_{CONTROL} \times \frac{R1 + R2}{R2}$$

Example: If $R1 = 0\Omega$ and $R2 = 5k\Omega$, Then
 $V_{OUT} = 5V$ nominal.
 Or, if $R1 = 10k\Omega$ and $R2 = 5k\Omega$ then
 $V_{OUT} = 15V$

Micropac Industries cannot assume any responsibility for any circuits shown or represent that they are free from patent infringement.
Micropac reserves the right to make changes at any time in order to improve design and to supply the best product possible.

Mechanical Configuration

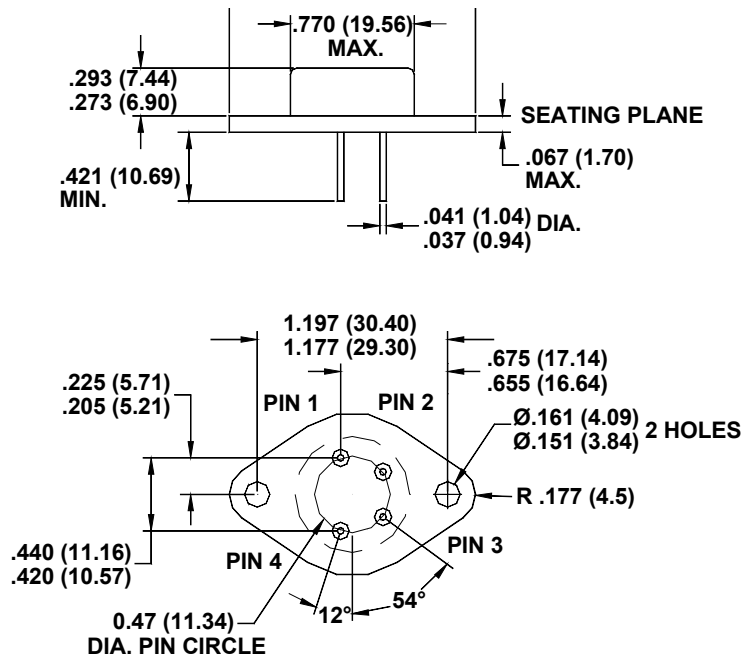

Test Circuit Adjustable Output Voltage

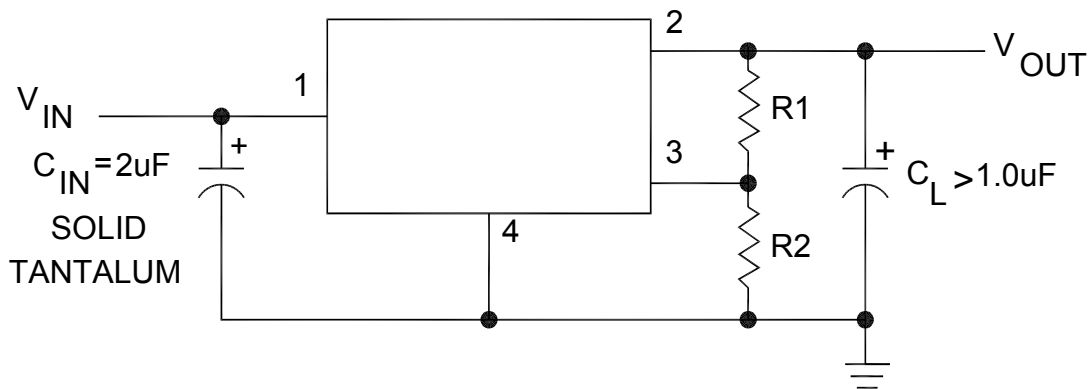

Note: All dimensions in inches and millimeters (parentheses).

Micropac Industries cannot assume any responsibility for any circuits shown or represent that they are free from patent infringement. Micropac reserves the right to make changes at any time in order to improve design and to supply the best product possible.