

**53252**

**90V - 0.8A DUAL POWER  
MOSFET OPTOCOUPERS  
DSCC DWG #5962-03247**



**Features:**

- 8-Pin Dual-In-Line Hermetic Package
- Performance over  $-55^{\circ}\text{C}$  to  $+125^{\circ}\text{C}$
- Compact Isolation Solid State Switches
- Continuous Output Current: 0.8 A <sup>(1)</sup>
- Optically Coupled between Input and Output
- Isolation Tested to 1000 VDC
- High Level of Transient Immunity
- 3 A Output Surge Current
- Shock and Vibration Resistant
- MIL-PRF-38534 screening optional

**Applications:**

- Military/High Reliability Systems
- Standard 28 VDC and 48 VDC Load Driver
- Aircraft Controls
- Electromechanical and Solid State Relay Replacement
- I/O Modules
- Switching Heaters

**DESCRIPTION**

The 53252 is two power MOSFET optocouplers in a single 8-pin dual-in-line package suitable for applications where two independent switches are required. The popular hermetic eight-pin dual-in-line ceramic package combined with 1000 VDC isolation between input and output and between two isolated relays, makes this device ideal for solid-state relay applications. Performance is specified over the full military temperature range. This device is available in a variety of quality levels from COTS to class H including any custom screening requirements. Gold plated leads are standard, but other lead finishes per MIL-PRF-38534 are also available.

Functionally, the device operates as two SPST, normally open (2 Form "A") solid-state relays. Each relay is actuated by an input current, which can be driven from a standard TTL device. The input current biases a light emitting diode that is optically coupled to an integrated photovoltaic diode array. The photovoltaic diode array energizes control circuitry that operates the output MOSFET.

Micropac Industries cannot assume any responsibility for any circuits shown or represent that they are free from patent infringement. Micropac reserves the right to make changes at any time in order to improve design and to supply the best product possible.

**ABSOLUTE MAXIMUM RATINGS:**  
(Per relay unless otherwise noted)

Storage Temperature Range .....	-65°C to +150°C
Operating Ambient Temperature - $T_A$ .....	-55°C to +125°C
Junction Temperature - $T_J$ .....	+150°C
Lead Solder Temperature for 10 seconds .....	+260°C
	(1.6 mm below seating plane)
Average Input Current - $I_F$ .....	20 mA
Peak Repetitive Input Current - $I_{Fpk}$ .....	40 mA
	(pulse width < 100 ms; duty cycle < 50%)
Peak Surge Input Current - $I_{Fpk}$ surge .....	100 mA
	(pulse width < 0.2 ms; duty cycle < 0.1%)
Continuous Output Current per relay - $I_O$ .....	0.8 A <sup>(1)</sup>
Single Shot Output Current per relay- $I_{Opk}$ surge (pulse width < 10 ms) .....	3 A
Output Voltage - $V_O$ .....	90 VDC

**RECOMMENDED OPERATING CONDITIONS:**

Parameter	Symbol	Min.	Max.	Units
Input Current (ON)	$I_{F(ON)}$	10	20	mA
Input Voltage (OFF)	$V_{F(OFF)}$	0	0.6	VDC
Operating Temperature	$T_A$	-55	+125	°C

Micropac Industries cannot assume any responsibility for any circuits shown or represent that they are free from patent infringement.  
Micropac reserves the right to make changes at any time in order to improve design and to supply the best product possible.

## ELECTRICAL SPECIFICATIONS

Test	Symbol	Conditions -55°C ≤ T <sub>A</sub> ≤ +125°C unless otherwise specified.	Group A subgroups	Device type	Limits		Unit
					Min	Max	
Output Withstand Voltage	V <sub>O(OFF)</sub>	V <sub>FOFF</sub> = 0.6 V, I <sub>O</sub> = 10 μA	1, 2, 3	All	90		V
Output On-Resistance 2/	R <sub>(ON)</sub>	I <sub>FON</sub> = 10 mA, I <sub>O</sub> = 800 mA, pulse duration ≤ 30 ms, duty cycles < 10%	1, 2, 3	All		1.2	Ω
Output Leakage Current	I <sub>O(OFF)</sub>	V <sub>FOFF</sub> = 0.6 V, V <sub>O</sub> = 90 V	1, 2, 3	All		10	μA
Input Forward Voltage	V <sub>FOFF</sub>	I <sub>FON</sub> = 10 mA	1, 2, 3	All	1.0	1.7	V
Input Reverse Breakdown Voltage	V <sub>R</sub>	I <sub>R</sub> = 10 μA	1, 2, 3	All	5.0		V
Input-Output Isolation Current 3/	I <sub>I-O</sub>	V <sub>I-O</sub> = 1000 V dc, t = 5 s, RH ≤ 45%, T <sub>A</sub> = +25°C	1, 2, 3	All		1.0	μA
Channel-Channel Isolation Current 3/	I <sub>ISO</sub>	V <sub>ISO</sub> = 1000 V dc, t = 5 s, RH ≤ 45%, T <sub>A</sub> = +25°C	1, 2, 3	All		1.0	μA
Turn-On Time 2/	t <sub>ON</sub>	I <sub>FON</sub> = 10 mA, I <sub>O</sub> = 800 mA, Pulse duration ≤ 30 ms, duty cycles < 10%	1, 2, 3	All		6.0	ms
Turn-Off time 2/	t <sub>OFF</sub>	I <sub>FON</sub> = 10 mA, I <sub>O</sub> = 800 mA, pulse duration ≤ 30 ms, duty cycles < 10%	1, 2, 3	All		2.0	ms

## Notes:

1. Maximum average current rating where the case temperature (T<sub>C</sub>) is maintained below 120°C.
2. During the pulsed R<sub>ON</sub> measurement (I<sub>O</sub> duration < 30 ms), ambient (T<sub>A</sub>) and case temperature (T<sub>C</sub>) are equal.
3. This is a momentary withstand test, not a continuous operating condition.
4. Typical junction to case thermal resistance (θ<sub>JC</sub>) for the device is 15°C/W, where case temperature (T<sub>C</sub>) is measured at the center of the package bottom.

## CAUTION:

Care should be taken not to exceed the maximum output power dissipation, maximum case temperature, and maximum junction temperature when repetitively switching loads.

Micropac Industries cannot assume any responsibility for any circuits shown or represent that they are free from patent infringement.  
Micropac reserves the right to make changes at any time in order to improve design and to supply the best product possible.

Case outlines	X, Y
Terminal number	Terminal symbol
1	+ IN 1
2	- IN 1
3	- OUT 2
4	+ OUT 2
5	+ IN 2
6	- IN 2
7	- OUT 1
8	+ OUT 1

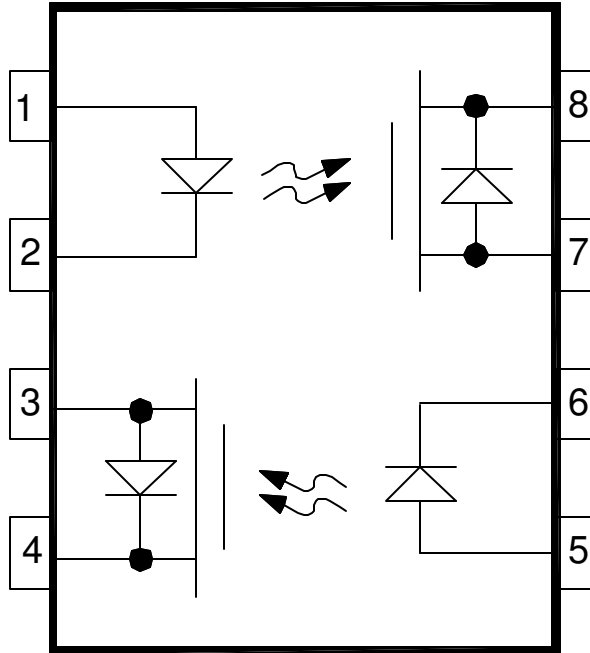

FIGURE 2. Terminal connections.

Input	Output
OFF	OFF
ON	ON

FIGURE 3. Truth table(s).

Micropac Industries cannot assume any responsibility for any circuits shown or represent that they are free from patent infringement. Micropac reserves the right to make changes at any time in order to improve design and to supply the best product possible.

Case outline X

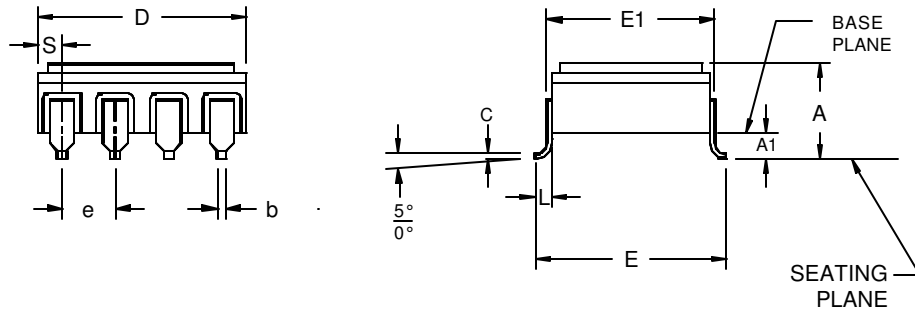

Symbol	Millimeters		Inches	
	Min	Max	Min	Max
A		6.99		.275
A1	1.40	1.65	.055	.065
b	0.41	0.53	.016	.021
c	0.18	0.33	.007	.013
D	9.40	9.91	.370	.390
e	2.29	2.79	.090	.110
E	9.65	9.91	.380	.390
E1		8.13		.320
L	1.07	1.32	.042	.052
S	0.89	1.27	.035	.050

Case outline Y

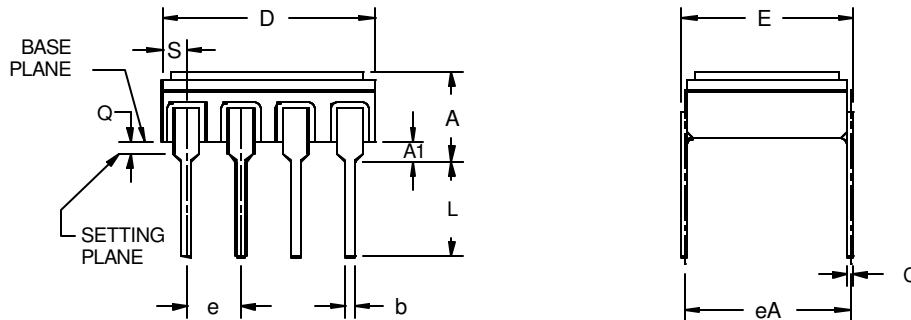

Symbol	Millimeters		Inches	
	Min	Max	Min	Max
A		6.60		.260
A1	0.76	1.27	.030	.050
b	0.41	0.53	.016	.021
c	0.18	0.33	.007	.013
D	9.40	9.91	.370	.390
e	2.29	2.79	.090	.110
E		8.13		.320
eA	7.37	7.87	.290	.310
L		12.70		.500
Q	0.51		.020	
S	0.89	1.27	.035	.050

NOTES:

1. The U.S. government preferred system of measurement is the metric SI. This item was designed using inch-pound units of measurement. In case of problems involving conflicts between the metric and in-pound units, the inch-pound units shall rule.
2. Pin 1 is indicated by the ESD triangle(s) marked on top of the package.

Micropac Industries cannot assume any responsibility for any circuits shown or represent that they are free from patent infringement. Micropac reserves the right to make changes at any time in order to improve design and to supply the best product possible.

The following chart explains the ordering procedure for Micropac Part Numbers.  
Please contact Micropac for other desired options.

Mii DASH NO.	CASE OUTLINE	LEAD FINISH	SCREENING LEVEL PER MIL-PRF-38534
53252-101	Y	SOLDER DIP	NO SCREENING
53252-102	Y	GOLD PLATE	NO SCREENING
53252-103	Y	SOLDER DIP	SCREENING PER TABLE C1X H LEVEL
53252-104	Y	GOLD PLATE	SCREENING PER TABLE C1X H LEVEL
53252-105	Y	SOLDER DIP	SCREENING PER TABLE C1X K LEVEL
53252-106	Y	GOLD PLATE	SCREENING PER TABLE C1X K LEVEL
53252-107	Y	SOLDER DIP	COMPLIANT TO H LEVEL
53252-108	Y	GOLD PLATE	COMPLIANT TO H LEVEL
53252-111	X	SOLDER DIP	SCREENING PER TABLE C1X H LEVEL
53252-112	X	GOLD PLATE	SCREENING PER TABLE C1X H LEVEL
53252-113	X	SOLDER DIP	SCREENING PER TABLE C1X K LEVEL
53252-114	X	GOLD PLATE	SCREENING PER TABLE C1X K LEVEL
53252-115	X	SOLDER DIP	NO SCREENING
53252-116	X	GOLD PLATE	NO SCREENING
53252-117	X	SOLDER DIP	COMPLIANT TO H LEVEL
53252-118	X	GOLD PLATE	COMPLIANT TO H LEVEL

Micropac Industries cannot assume any responsibility for any circuits shown or represent that they are free from patent infringement.  
Micropac reserves the right to make changes at any time in order to improve design and to supply the best product possible.