

53124

POWER MOSFET OPTOCOUPLER
RADIATION TOLERANT, ± 90V - 0.8A

Mii

MICROCIRCUITS DIVISION

Features:

- Design Tested to 100 krad (Si) Total Dose
- Hermetically Sealed in 8-Pin Dual-In-Line Package
- Performance over -55°C to +125°C
- Compact Solid State Bi-directional Switch
- AC/DC Power Switching
- Maximum Average Current
 - AC/DC: 0.8 A ⁽¹⁾
 - DC only: 1.6 A ⁽¹⁾
- Per Derating Curves (Figure 3)
 - AC/DC: 0.5 A
 - DC only: 1.0 A
- Optically Coupled
- Input/Output Isolation Tested to 1500 VDC
- High Level of Transient Immunity
- 3 A Output Surge Current
- Shock and Vibration Resistant
- MIL-PRF-38534
- Same foot print as HSSR7111 / Mii 53111 & Electrically Similar

Applications:

- Satellite/Space systems
- Military/High Reliability Systems
- Standard 28 VDC and 48 VDC Load Driver
- Standard 24 VAC Load Driver
- Aircraft Controls
- AC/DC Electromechanical and Solid State Relay Replacement
- I/O Modules
- Switching Heaters

DESCRIPTION

The 53124 is a single channel power MOSFET optocoupler which is suitable as a pin for pin replacement for the Mii 53111 when radiation tolerant performance and similar electrical performance to the 53111 is required. The primary difference between the 53124 and 53111 is that the radiation tolerant power MOSFETs employed in the 53124 exhibit a higher $R_{DS(ON)}$. The higher values of $R_{DS(ON)}$ results in a lower current for the same power dissipation or higher power dissipation for the same current levels relative to the 53111.

The popular eight pin, hermetic dual-in-line ceramic package combined with 1500 VDC isolation between input and output, makes this optocoupler ideal for solid-state relay applications. Performance is specified over the full military temperature range. This device is available as COTS, or as fully compliant MIL-PRF-38534 Class H or with custom screening. Lead options support both through-hole and surface-mount assembly. Gold plated leads are standard, but other lead finishes per MIL-PRF-38534 are also available.

Functionally, the device operates as a single-pole, normally open (1 Form A) solid-state relay. The device is actuated by an input current, which can be supplied from standard logic types such as open-collector TTL. The input current biases a light emitting diode that is optically coupled to an integrated photovoltaic diode array. The photovoltaic array powers control circuitry that operates the output MOSFETs. Optimum switching of either AC or DC loads is provided by a configurable output. For AC loads, Connection A in Figure 1 must be used. Connection A will also switch DC loads but Connection B, in Figure 1, provides DC-only operation with the advantages of substantial reduction in on-resistance and twice the output current capability as that obtained with Connection A.

RADIATION TOLERANT

This device contains radiation hardened components and/or other features that provide a level of radiation tolerance. Micropac does not guarantee any level of radiation hardness. Specific lot testing is required to determine the level of radiation hardness. Micropac does not offer this device as compliant to Appendix G (RHA Requirements) of MIL-PRF-38534.

Micropac Industries cannot assume any responsibility for any circuits shown or represent that they are free from patent infringement.
Micropac reserves the right to make changes at any time in order to improve design and to supply the best product possible.

ABSOLUTE MAXIMUM RATINGS:

Storage Temperature Range	-65°C to +150°C
Operating Ambient Temperature - T _A	-55°C to +125°C
Junction Temperature - T _J	+150°C
Operating Case Temperature - T _c	+145°C ⁽²⁾
Lead Solder Temperature for 10 seconds	+260°C
	(1.6 mm below seating plane)
Average Input Current - I _F	20 mA
Peak Repetitive Input Current - I _{Fpk}	40 mA
	(Pulse width < 100 ms; duty cycle < 50%)
Peak Surge Input Current - I _{Fpk} surge	100 mA
	(Pulse width < 0.2 ms; duty cycle < 0.1%)
Reverse Input Voltage - V _R	5 V
Average Output Current	
Connection A - I _O	0.8 A ⁽¹⁾
Connection B - I _O	1.6 A ⁽¹⁾
Average Output Current, derated per Figure 3	
Connection A - I _O	0.5 A
Connection B - I _O	1.0 A
Single Shot Output Current - Figure 4	
Connection A - I _{Opk} surge (Pulse width < 10 ms)	3 A
Connection B - I _{Opk} surge (Pulse width < 10 ms)	6 A
Output Voltage	
Connection A - V _O	-90 V to +90 V
Connection B - V _O	0 V to +90 V
Average Output Power Dissipation - Figure 5	800 mW ⁽³⁾
Thermal Impedance Junction to Case (Input Diode)	223.4°C/W
Thermal Impedance Junction to Case (Output Transistor)	10°C/W

RECOMMENDED OPERATING CONDITIONS:

Parameter	Symbol	Min.	Max.	Units
Input Current (ON)	I _{F(ON)}	5	20	mA
Input Voltage (OFF)	V _{F(OFF)}	0	0.6	VDC
Operating Temperature	T _A	-55	+125	°C

Micropac Industries cannot assume any responsibility for any circuits shown or represent that they are free from patent infringement. Micropac reserves the right to make changes at any time in order to improve design and to supply the best product possible.

ELECTRICAL SPECIFICATIONS (Pre-Irradiation)T_A = -55°C to +125°C, unless otherwise specified.

Parameter	Symbol	Min.	Typ.*	Max.	Units	Test Conditions	Notes
Output Withstand Voltage	$ V_{O(OFF)} $	90	110		V	V _F = 0.6 V I _O = 10 μA	
Output On-Resistance (Connection A)	R _(ON)		0.8	2.5	Ω	I _F = 10 mA I _O = 500 mA (pulse duration ≤ 30 ms)	4, Figure 1
Output On-Resistance (Connection B)			0.2	0.7	Ω	I _F = 10 mA I _O = 1 A (pulse duration ≤ 30 ms)	
Output Leakage Current	I _{O(OFF)}		10 ⁻⁴	10	μA	V _F = 0.6 V V _O = 90 V	
Input Forward Voltage	V _F	1.0	1.7	2.1	V	I _F = 10 mA	
Input Reverse Breakdown Voltage	V _R	5			V	I _F = 10 μA	
Input-Output Insulation	I _{I-O}			1	μA	RH ≤ 45%, t = 5 s V _{I-O} = 1500 VDC T _A = 25°C	5, 6
Turn-On Time	t _{ON}		1.25	6	ms	I _F = 10 mA V _{DD} = 28 V I _O = 800 mA	Figure 6
Turn-Off time	t _{OFF}			0.25	ms	I _F = 10 mA V _{DD} = 28 V I _O = 800 mA	Figure 6
Output Transient Rejection	$\left \frac{dV_O}{dt} \right $	1000			V/μs	V _{PEAK} = 50 V C _M = 1000 pF C _L = 15 pF R _M ≥ 1 MΩ	Figure 7
Input-Output Transient Rejection	$\left \frac{dV_{I-O}}{dt} \right $	500			V/μs	V _{DD} = 5 V V _{I-O (PEAK)}} = 50 V R _L = 20 kΩ C _L = 15 pF	Figure 8

* All typical values are at T_A = 25°C, I_{F(ON)} = 10 mA, V_{F(OFF)} = 0.6 V unless otherwise specified.

Micropac Industries cannot assume any responsibility for any circuits shown or represent that they are free from patent infringement.
Micropac reserves the right to make changes at any time in order to improve design and to supply the best product possible.

TYPICAL CHARACTERISTICS - (Pre-Irradiation)

All typical values are at $T_A = 25^\circ\text{C}$, $I_{F(ON)} = 10\text{ mA}$, $V_{F(OFF)} = 0.6\text{ V}$ unless otherwise specified.

Parameter	Symbol	Test Conditions	Typical Value	Units	Notes
Output Off-Capacitance	$C_{O(OFF)}$	$V_O = 28\text{ V}$ $f = 1\text{ MHz}$	145	pF	
Output Offset Voltage	$ V_{OS} $	$I_F = 10\text{ mA}$ $I_O = 0\text{ mA}$	2	μV	7
Input Diode Temperature Coefficient	$\Delta V_F / \Delta T_A$	$I_F = 10\text{ mA}$	-1.4	$\text{mV}/^\circ\text{C}$	
Input Capacitance	C_{IN}	$V_F = 0\text{ V}$ $f = 1\text{ MHz}$	20	pF	8
Input-Output Capacitance	C_{I-O}	$V_{I-O} = 0\text{ V}$ $f = 1\text{ MHz}$	1.5	pF	5
Input-Output Resistance	R_{I-O}	$V_{I-O} = 500\text{ V}$ $t = 60\text{ s}$	10^{13}	Ω	5

Notes:

1. Maximum average current rating where the case temperature (T_C) is maintained below 120°C .
2. Maximum junction to case thermal resistance for the device is $10^\circ\text{C}/\text{W}$, where case temperature (T_C) is measured at the center of the package bottom.
3. For rating, see Figure 5. The output power P_D rating curve is obtained when the part is handling the maximum average output current I_O as shown in Figure 3.
4. During the pulsed R_{ON} measurement (I_O duration $< 30\text{ ms}$), ambient (T_A) and case temperature (T_C) are equal.
5. Pins 2 through 3 shorted together and pins 5 through 8 shorted together.
6. This is a momentary withstand test, not an operating condition.
7. V_{OS} is a function of I_F and is defined between pins 5 and 8, with pin 5 as the reference. V_{OS} must be measured in a stable ambient (free of temperature gradients).
8. Zero-bias capacitance measured between the LED anode and cathode.

CAUTION:

Care should be taken not to exceed the maximum output power dissipation, maximum case temperature, and maximum junction temperature when repetitively switching loads.

Micropac Industries cannot assume any responsibility for any circuits shown or represent that they are free from patent infringement. Micropac reserves the right to make changes at any time in order to improve design and to supply the best product possible.

Case Outlines	P, X and Y	
Terminal number	Terminal symbol	
	Connection A (AC or DC load)	Connection B (DC load only)
1	NC	NC
2	V _{F+}	V _{F+}
3	V _{F-}	V _{F-}
4	NC	NC
5	V _{O-}	V _{O+}
6	NC	NC
7	NC	N _{O-}
8	V _{O+}	V _{O+}

NC = No Connection

CONNECTION A
AC/DC CONNECTION

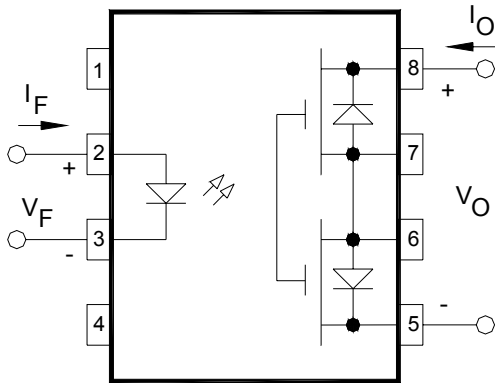

CONNECTION B
DC CONNECTION

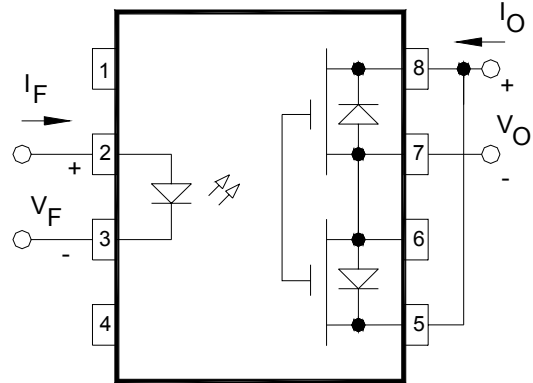

Figure 1 - Terminal Connections

INPUT	OUTPUT
OFF	OFF
ON	ON

Figure 2 - Truth Table

Micropac Industries cannot assume any responsibility for any circuits shown or represent that they are free from patent infringement. Micropac reserves the right to make changes at any time in order to improve design and to supply the best product possible.

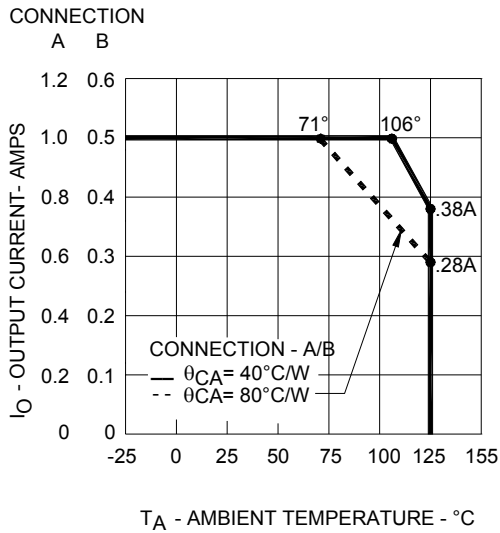

Figure 3. Maximum Average Output Current Rating vs. Ambient Temperature.

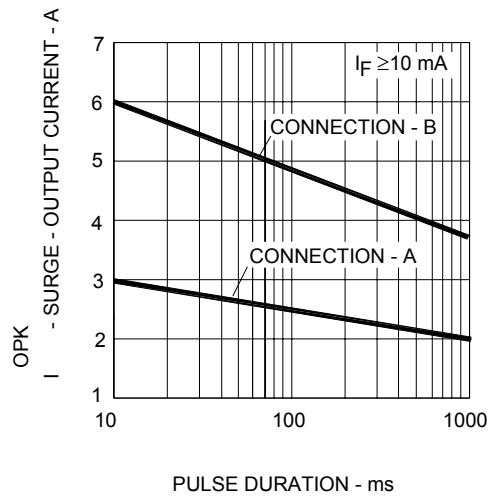

Figure 4. Single Shot (non-repetitive) Output Current vs. Pulse Duration.

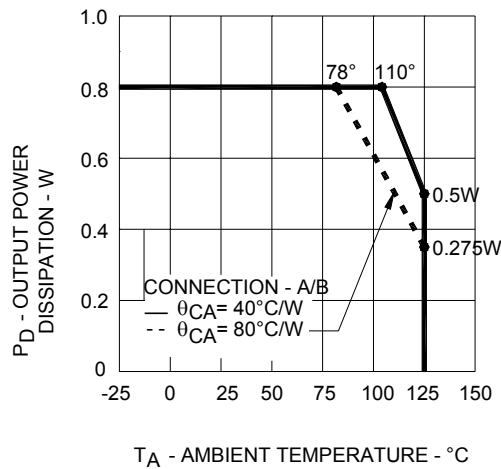
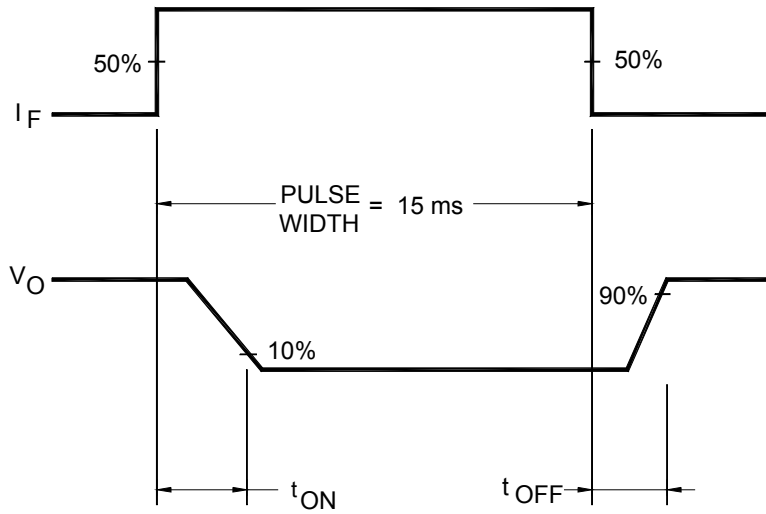
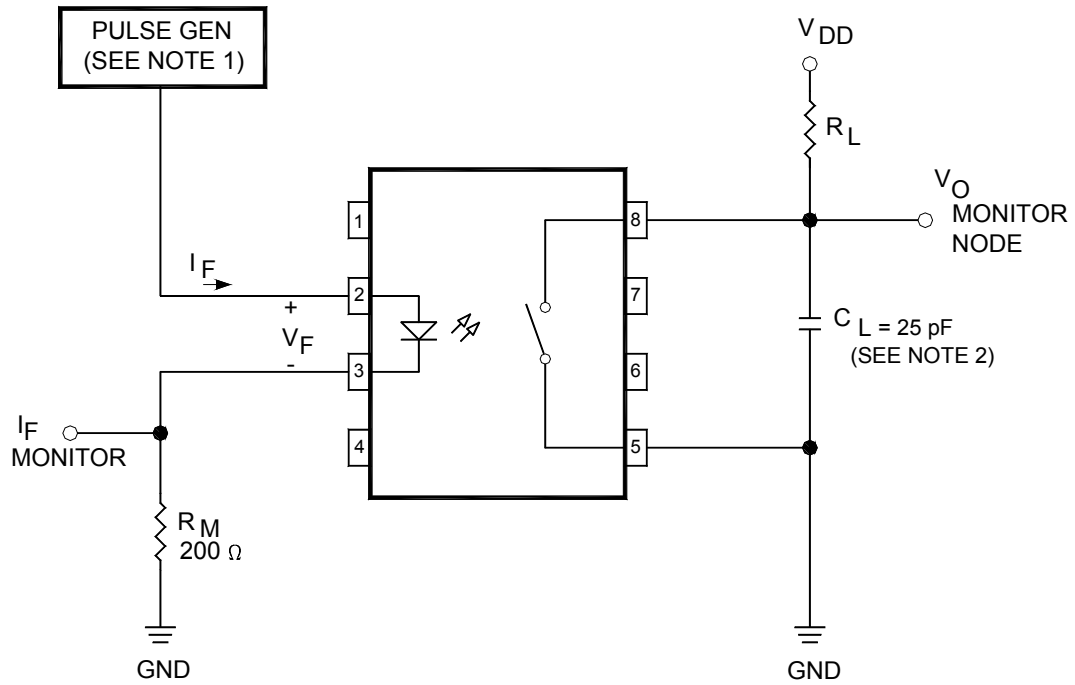

Figure 5. Output Power Rating vs. Ambient Temperature.

Micropac Industries cannot assume any responsibility for any circuits shown or represent that they are free from patent infringement. **Micropac** reserves the right to make changes at any time in order to improve design and to supply the best product possible.



NOTES:

1. PULSE GENERATOR HAS THE FOLLOWING CHARACTERISTICS: OUTPUT IMPEDANCE = 50 Ω AND $t_r = t_f = 5.0$ ns.
2. LOAD CAPACITANCE (C_L) INCLUDES PROBE AND JIG CAPACITANCE.

Figure 6. Switching Test Circuit and Waveform.

Micropac Industries cannot assume any responsibility for any circuits shown or represent that they are free from patent infringement. Micropac reserves the right to make changes at any time in order to improve design and to supply the best product possible.

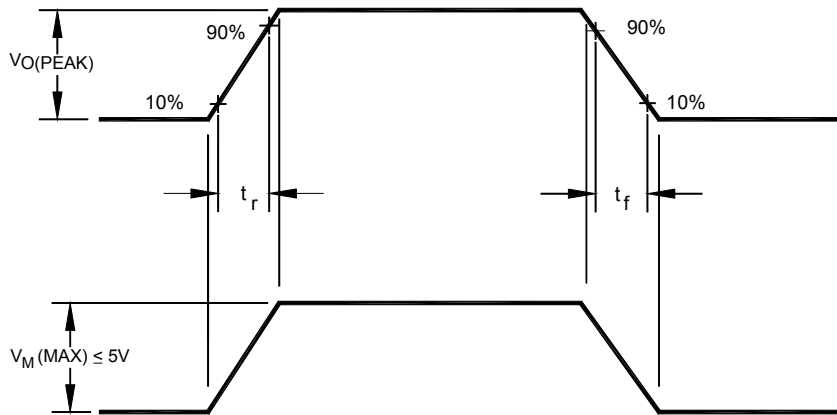
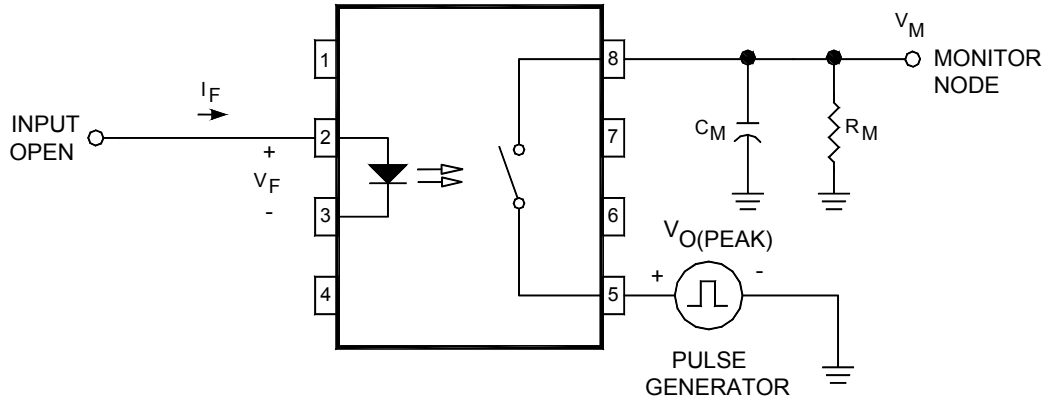

$$\frac{dV_O}{dt} = \frac{(0.8)V_O(PEAK)}{t_r} \quad \text{OR} \quad \frac{(0.8)V_O(PEAK)}{t_f}$$

OVERSHOOT ON \$V_O(PEAK)\$ IS TO BE \$\le 10\%\$

NOTES:

1. \$C_M\$ INCLUDES PROBE AND FIXTURE CAPACITANCE.
2. \$R_M\$ INCLUDES PROBE AND FIXTURE RESISTANCE.

Figure 7. Output Transient Rejection Test Circuit and Waveform.

Micropac Industries cannot assume any responsibility for any circuits shown or represent that they are free from patent infringement. Micropac reserves the right to make changes at any time in order to improve design and to supply the best product possible.

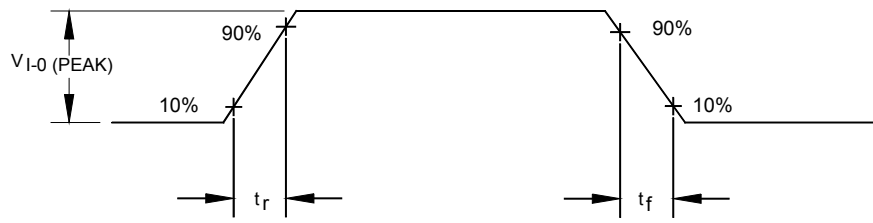
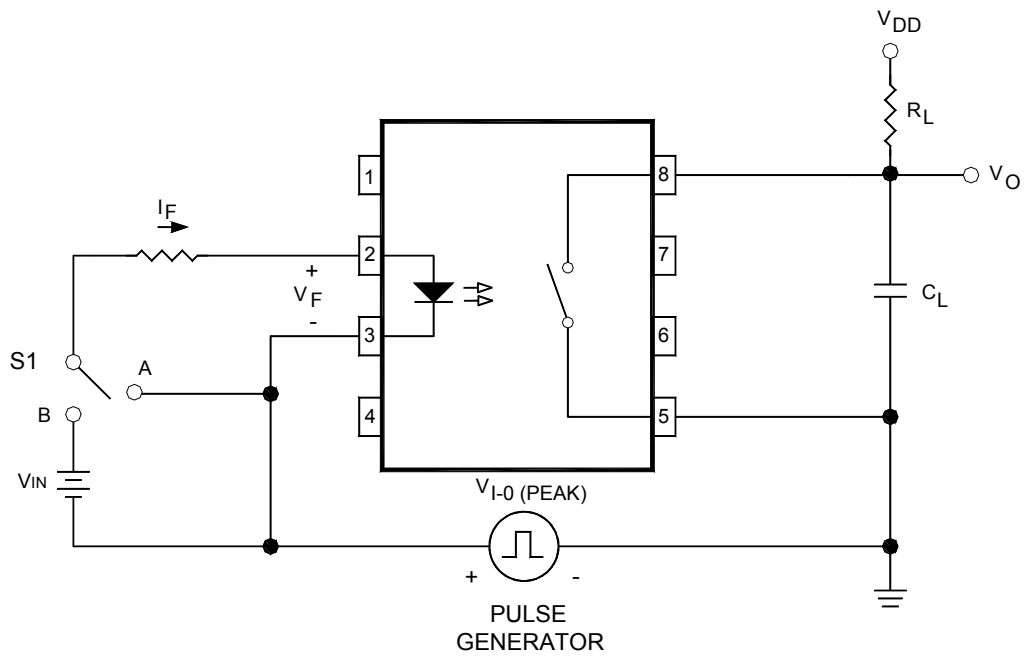

V_O (OFF) S_1 AT A ($V_F = 0$ V) V_O (OFF) (MIN) ≥ 3.25 V
 V_O (ON) S_1 AT B ($I_F = 10$ mA) V_O (ON) (MAX) ≤ 0.8 V

$$\frac{dV_{I-0}}{dt} = \frac{(0.8) V_{I-0} (PEAK)}{t_r} \quad \text{OR} \quad \frac{(0.8) V_{I-0} (PEAK)}{t_f}$$

OVERSHOOT ON V_{I-0} (PEAK) IS TO BE $\leq 10\%$

- NOTES:
 1. LOAD CAPACITANCE (C_L) INCLUDES PROBE AND FIXTURE CAPACITANCE.

Micropac Industries cannot assume any responsibility for any circuits shown or represent that they are free from patent infringement. Micropac reserves the right to make changes at any time in order to improve design and to supply the best product possible.

TOTAL DOSE TEST RESULTS

Disclaimer: The data of 4 representative units irradiated in Cobalt-60 chamber is only typical of one lot of solid state relays. Micropac does not guarantee performance of its SSR to these radiation levels. Individual lots have to be screened to guarantee the performance.

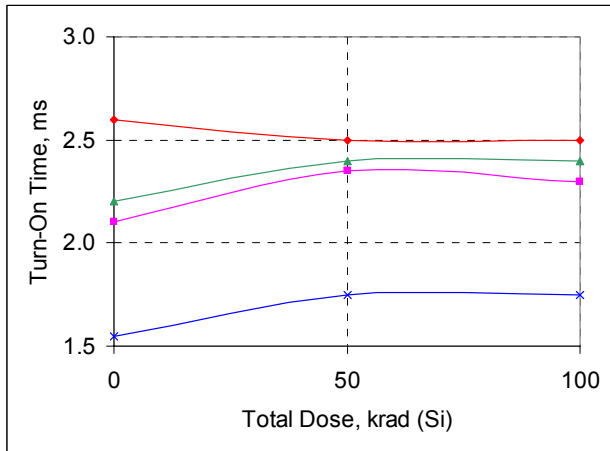

Figure 9. Turn-On Time vs Total Dose at $V_{out} = 28\text{ V}$, $R_{load} = 35\ \Omega$, $I_{in} = 15\text{ mA}$, 10% duty cycle.

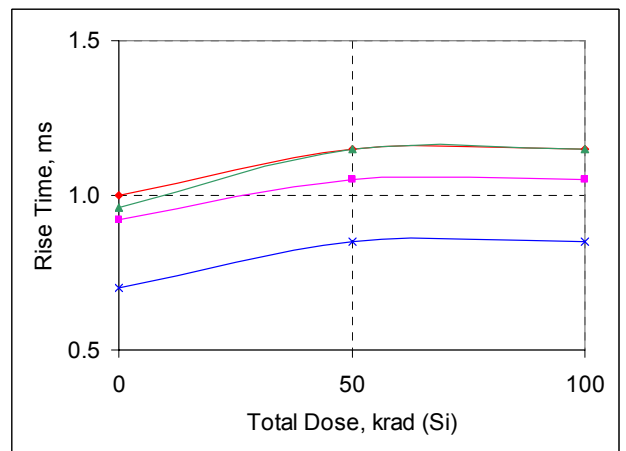

Figure 10. Rise Time vs Total Dose at $V_{out} = 28\text{ V}$, $R_{load} = 35\ \Omega$, $I_{in} = 15\text{ mA}$, 10% duty cycle.

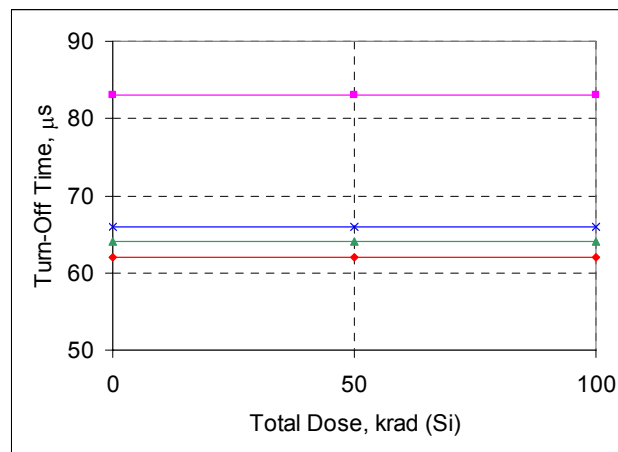

Figure 11. Turn-Off Time vs Total Dose at $V_{out} = 28\text{ V}$, $R_{load} = 35\ \Omega$, $I_{in} = 15\text{ mA}$, 10% duty cycle.

Micropac Industries cannot assume any responsibility for any circuits shown or represent that they are free from patent infringement. Micropac reserves the right to make changes at any time in order to improve design and to supply the best product possible.

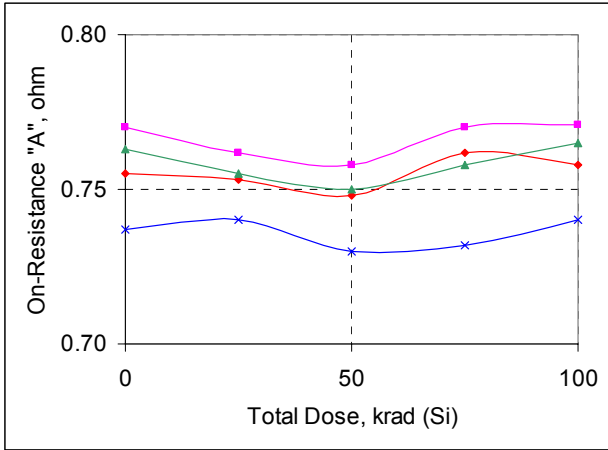

Figure 12. On-Resistance "A" vs Total Dose at $I_F = 10 \text{ mA}$, $I_{out} = 40 \text{ mA}$ for 1second.

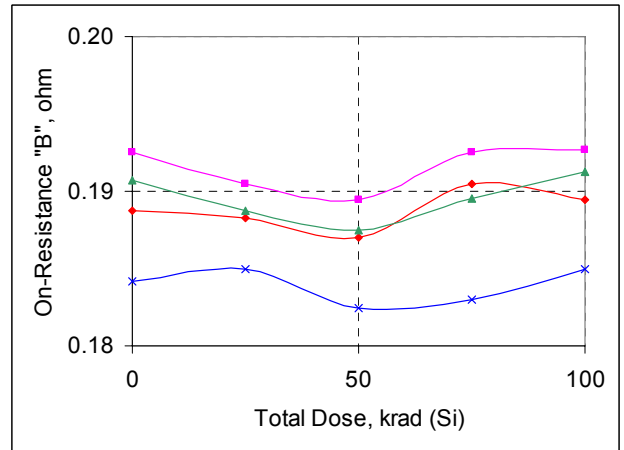

Figure 13. On-Resistance "B" vs Total Dose at $I_F = 10 \text{ mA}$, $I_{out} = 40 \text{ mA}$ for 1second.

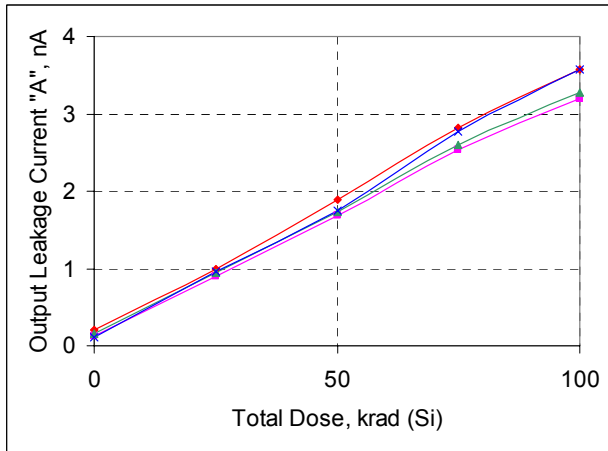

Figure 14. Output Leakage Current "A" vs Total Dose at $V_F = 1.0 \text{ V}$, $V_{out} = 90 \text{ V}$.

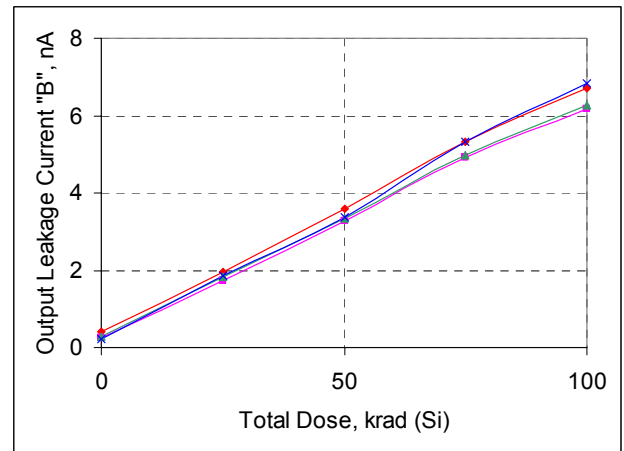

Figure 15. Output Leakage Current "B" vs Total Dose at $V_F = 1.0 \text{ V}$, $V_{out} = 90 \text{ V}$.

Micropac Industries cannot assume any responsibility for any circuits shown or represent that they are free from patent infringement. Micropac reserves the right to make changes at any time in order to improve design and to supply the best product possible.

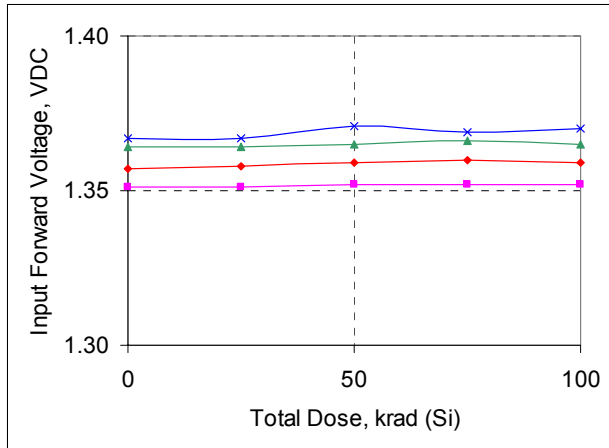

Figure 16. Input Forward Voltage vs Total Dose at $I_F = 15$ mA.

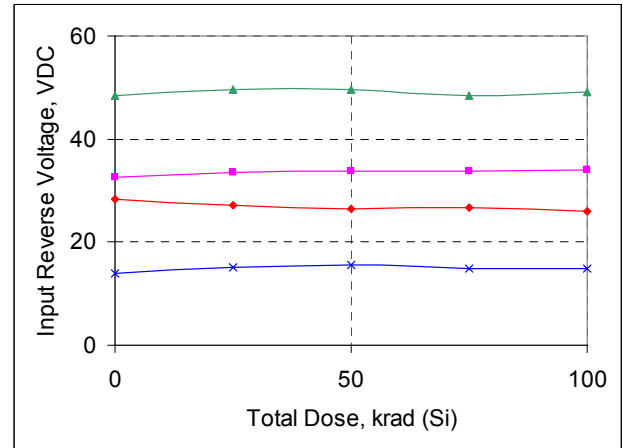
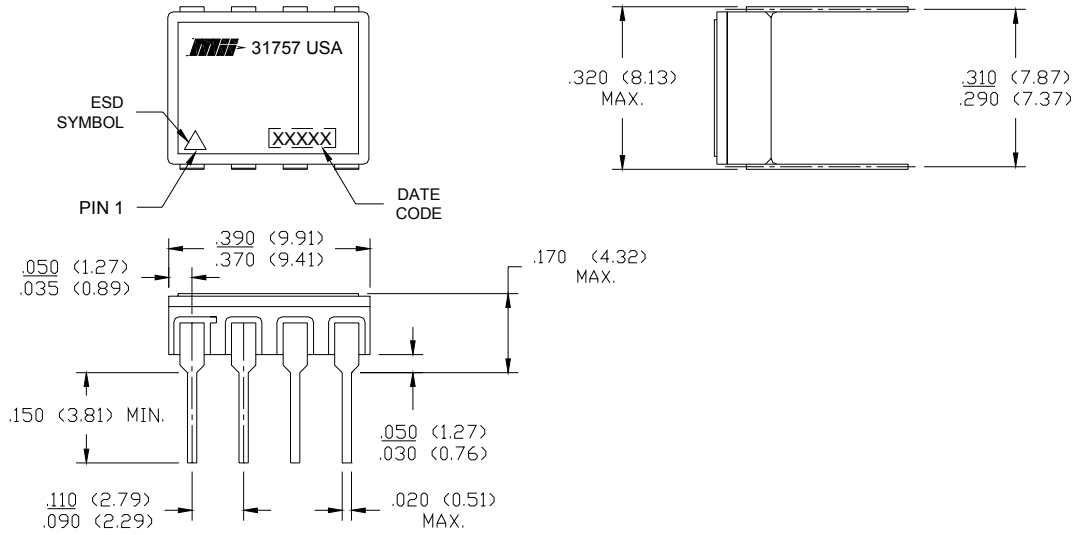

Figure 17. Input Reverse Voltage vs Total Dose at $I_R = 10$ μ A.

Micropac Industries cannot assume any responsibility for any circuits shown or represent that they are free from patent infringement. Micropac reserves the right to make changes at any time in order to improve design and to supply the best product possible.

CASE OUTLINE P



CASE OUTLINE X

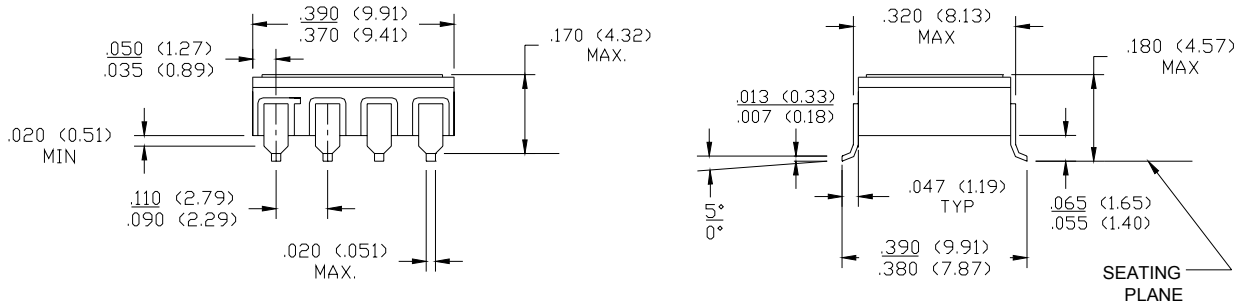

CASE OUTLINE Y

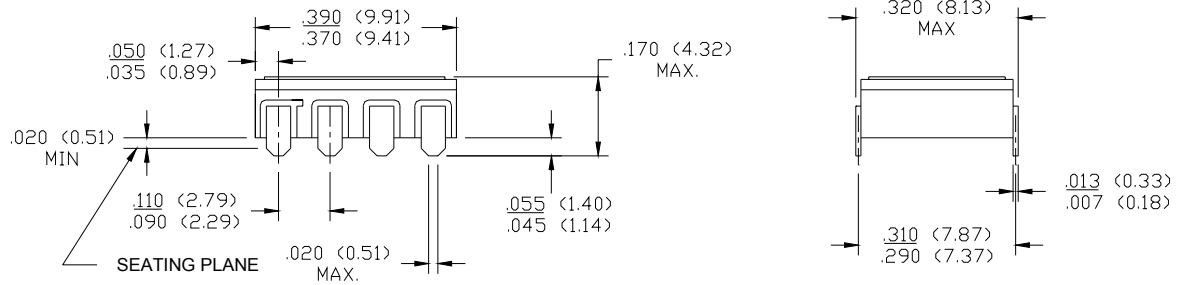

Notes:

1. Pin 1 is indicated by the ESD Triangles marked on the lid of the package.
2. Dimensions are in inches (mm).
3. Metric equivalents are given for general information only.
4. Unless otherwise specified, Tolerance is ± 005 (0.13mm)
5. The package is an 8 lead, side brazed ceramic package. The weld ring is Kovar and the leads are Alloy 42. Plating is 50 micro inches minimum gold over 100 micro inches minimum of nickel.

Micropac Industries cannot assume any responsibility for any circuits shown or represent that they are free from patent infringement. Micropac reserves the right to make changes at any time in order to improve design and to supply the best product possible.

Ordering Guide

The following chart explains the ordering procedure for Micropac Part Numbers.
Please contact Micropac for other desired options.

Mii DASH NO.	PIN STYLE	LEAD FINISH	SCREENING LEVEL PER MIL-PRF-38534
53124-101	DIP	SOLDER DIP	NO SCREENING
53124-102	DIP	GOLD PLATE	NO SCREENING
53124-103	DIP	SOLDER DIP	SCREENING TO "H" LEVEL
53124-104	DIP	GOLD PLATE	SCREENING TO "H" LEVEL
53124-105	DIP	SOLDER DIP	SCREENING TO "K" LEVEL
53124-106	DIP	GOLD PLATE	SCREENING TO "K" LEVEL
53124-107	DIP	SOLDER DIP	"H" LEVEL
53124-108	DIP	GOLD PLATE	"H" LEVEL
53124-109	DIP	SOLDER DIP	"K" LEVEL
53124-110	DIP	GOLD PLATE	"K" LEVEL
53124-111	GULL WING	SOLDER DIP	SCREENING TO "H" LEVEL
53124-112	GULL WING	GOLD PLATE	SCREENING TO "H" LEVEL
53124-113	GULL WING	SOLDER DIP	SCREENING TO "K" LEVEL
53124-114	GULL WING	GOLD PLATE	SCREENING TO "K" LEVEL
53124-115	GULL WING	SOLDER DIP	NO SCREENING
53124-116	GULL WING	GOLD PLATE	NO SCREENING
53124-117	GULL WING	SOLDER DIP	"H" LEVEL
53124-118	GULL WING	GOLD PLATE	"H" LEVEL
53124-119	GULL WING	SOLDER DIP	"K" LEVEL
53124-120	GULL WING	GOLD PLATE	"K" LEVEL

1. "Screening" to H or K Level is only the 100% screening per Table CIX of MIL-PRF-38534 and does not include element evaluation or Quality Conformance Inspection per MIL-PRF-38534.

Micropac Industries cannot assume any responsibility for any circuits shown or represent that they are free from patent infringement.
Micropac reserves the right to make changes at any time in order to improve design and to supply the best product possible.