

**53272****POWER MOSFET OPTOCOUPLER****± 90V – 2.0A****Mii**

**MICROPAC INDUSTRIES  
MICROCIRCUITS PRODUCTS  
DIVISION**

**Features:**

- Performance over –55°C to +125°C
- Compact Solid State Bi-directional Switch
- AC/DC Power Switching
- Maximum Average Current
  - AC/DC: 1.0 A <sup>(1)</sup>
  - DC only: 2.0 A <sup>(1)</sup>
- Optically Coupled
- Input/Output Isolation Tested to 1000 VDC
- High Level of Transient Immunity
- 3 A Output Surge Current
- Shock and Vibration Resistant
- MIL-PRF-38534
- Electrically Similar to the 53124

**Applications:**

- Satellite/Space systems
- Military/High Reliability Systems
- Standard 28 VDC and 48 VDC Load Driver
- Standard 24 VAC Load Driver
- Aircraft Controls
- AC/DC Electromechanical and Solid State Relay Replacement
- I/O Modules
- Switching Heaters

**DESCRIPTION**

The 53272 is a single channel power MOSFET optocoupler expanding upon the electrical performance of Mii P/N 53124 with reduced  $R_{DS(ON)}$  and increased current capability.

Performance is specified over the full military temperature range. Functionally, the device operates as a single-pole, normally open (1 Form A) solid-state relay. The device is actuated by an input current, which can be supplied from standard logic types such as open-collector TTL. The input current biases a light emitting diode that is optically coupled to an integrated photovoltaic diode array. The photovoltaic array powers control circuitry that operates the output MOSFETs. Optimum switching of either AC or DC loads is provided by a configurable output. For AC loads, Connection A in Figure 1 must be used. Connection A will also switch DC loads but Connection B, in Figure 1, provides DC-only operation with the advantages of substantial reduction in on-resistance and twice the output current capability as that obtained with Connection A.

**Micropac Industries** cannot assume any responsibility for any circuits shown or represent that they are free from patent infringement. **Micropac** reserves the right to make changes at any time in order to improve design and to supply the best product possible.

**ABSOLUTE MAXIMUM RATINGS:**

Storage Temperature Range .....	-65°C to +150°C
Operating Ambient Temperature - T <sub>A</sub> .....	-55°C to +125°C
Junction Temperature - T <sub>J</sub> .....	+150°C
Operating Case Temperature - T <sub>C</sub> .....	+145°C <sup>(2)</sup>
Lead Solder Temperature for 10 seconds .....	+260°C
	(1.6 mm below seating plane)
Average Input Current - I <sub>F</sub> .....	20 mA
Peak Repetitive Input Current - I <sub>Fpk</sub> .....	40 mA
	(Pulse width < 100 ms; duty cycle < 50%)
Peak Surge Input Current - I <sub>Fpk</sub> surge .....	100 mA
	(Pulse width < 0.2 ms; duty cycle < 0.1%)
Reverse Input Voltage - V <sub>R</sub> .....	5 V
Average Output Current	
Connection A - I <sub>O</sub> .....	1.0 A <sup>(1)</sup>
Connection B - I <sub>O</sub> .....	2.0 A <sup>(1)</sup>
Average Output Current, derated per Figure 3	
Connection A - I <sub>O</sub> .....	0.8 A
Connection B - I <sub>O</sub> .....	1.6 A
Single Shot Output Current - Figure 4	
Connection A - I <sub>Opk</sub> surge (Pulse width < 10 ms) .....	4 A
Connection B - I <sub>Opk</sub> surge (Pulse width < 10 ms) .....	8 A
Output Voltage	
Connection A - V <sub>O</sub> .....	-90 V to +90 V
Connection B - V <sub>O</sub> .....	0 V to +90 V
Average Output Power Dissipation - Figure 5 .....	800 mW <sup>(3)</sup>

**RECOMMENDED OPERATING CONDITIONS:**

Parameter	Symbol	Min.	Max.	Units
Input Current (ON)	I <sub>F(ON)</sub>	5	20	mA
Input Voltage (OFF)	V <sub>F(OFF)</sub>	0	0.6	VDC
Operating Temperature	T <sub>A</sub>	-55	+125	°C

Micropac Industries cannot assume any responsibility for any circuits shown or represent that they are free from patent infringement. Micropac reserves the right to make changes at any time in order to improve design and to supply the best product possible.

**ELECTRICAL SPECIFICATIONS**  $T_A = -55^\circ\text{C}$  to  $+125^\circ\text{C}$ , unless otherwise specified.

Parameter	Symbol	Min.	Typ.*	Max.	Unit	Test Conditions	Notes
Output Withstand Voltage	$ V_{O(OFF)} $	90	110		V	$V_F = 0.6\text{ V}$ $I_O = 10\ \mu\text{A}$	
Output On-Resistance (Connection A)	$R_{(ON)}$		.40	.68	$\Omega$	$I_F = 10\text{ mA}$ $I_O = 1\text{ A}$ (pulse duration $\leq 30\text{ ms}$ )	4, Figure 1
Output On-Resistance (Connection B)			0.10	0.18	$\Omega$	$I_F = 10\text{ mA}$ $I_O = 1\text{ A}$ (pulse duration $\leq 30\text{ ms}$ )	
Output Leakage Current	$I_{O(OFF)}$		$10^{-4}$	10	$\mu\text{A}$	$V_F = 0.6\text{ V}$ $V_O = 90\text{ V}$	
Input Forward Voltage	$V_F$	1.0	1.7	2.1	V	$I_F = 10\text{ mA}$	
Input Reverse Breakdown Voltage	$V_R$	5			V	$I_F = 10\ \mu\text{A}$	
Input-Output Insulation	$I_{I-O}$			1	$\mu\text{A}$	$RH \leq 45\%$ , $t = 5\text{ s}$ $V_{I-O} = 1000\text{ VDC}$ $T_A = 25^\circ\text{C}$	5, 6
Turn-On Time	$t_{ON}$		2.0	8	ms	$I_F = 10\text{ mA}$ $V_{DD} = 28\text{ V}$ $I_O = 800\text{ mA}$	Figure 6
Turn-Off time	$t_{OFF}$			0.3	ms	$I_F = 10\text{ mA}$ $V_{DD} = 28\text{ V}$ $I_O = 800\text{ mA}$	Figure 6

\* All typical values are at  $T_A = 25^\circ\text{C}$ ,  $I_{F(ON)} = 10\text{ mA}$ ,  $V_{F(OFF)} = 0.6\text{ V}$  unless otherwise specified.

Micropac Industries cannot assume any responsibility for any circuits shown or represent that they are free from patent infringement.  
Micropac reserves the right to make changes at any time in order to improve design and to supply the best product possible.

**TYPICAL CHARACTERISTICS**

All typical values are at  $T_A = 25^\circ\text{C}$ ,  $I_{F(\text{ON})} = 10\text{ mA}$ ,  $V_{F(\text{OFF})} = 0.6\text{ V}$  unless otherwise specified.

Parameter	Symbol	Test Conditions	Typical Value	Units	Notes
Output Off-Capacitance	$C_{O(\text{OFF})}$	$V_O = 28\text{ V}$ $f = 1\text{ MHz}$	145	pF	
Output Offset Voltage	$ V_{OS} $	$I_F = 10\text{ mA}$ $I_O = 0\text{ mA}$	2	$\mu\text{V}$	7
Input Diode Temperature Coefficient	$\Delta V_F / \Delta T_A$	$I_F = 10\text{ mA}$	-1.4	$\text{mV}/^\circ\text{C}$	
Input Capacitance	$C_{IN}$	$V_F = 0\text{ V}$ $f = 1\text{ MHz}$	20	pF	8
Input-Output Capacitance	$C_{I-O}$	$V_{I-O} = 0\text{ V}$ $f = 1\text{ MHz}$	1.5	pF	5
Input-Output Resistance	$R_{I-O}$	$V_{I-O} = 500\text{ V}$ $t = 60\text{ s}$	$10^{13}$	$\Omega$	5

**Notes:**

1. Maximum average current rating where the case temperature ( $T_C$ ) is maintained below  $120^\circ\text{C}$ .
2. Maximum junction to case thermal resistance for the device is  $15^\circ\text{C}/\text{W}$ , where case temperature ( $T_C$ ) is measured at the center of the package bottom.
3. For rating, see Figure 5. The output power  $P_D$  rating curve is obtained when the part is handling the maximum average output current  $I_O$  as shown in Figure 3.
4. During the pulsed  $R_{ON}$  measurement ( $I_O$  duration  $< 30\text{ ms}$ ), ambient ( $T_A$ ) and case temperature ( $T_C$ ) are equal.
5. Pins 2 through 3 shorted together and pins 5 through 8 shorted together.
6. This is a momentary withstand test, not an operating condition.
7.  $V_{OS}$  is a function of  $I_F$  and is defined between pins 5 and 8, with pin 5 as the reference.  $V_{OS}$  must be measured in a stable ambient (free of temperature gradients).
8. Zero-bias capacitance measured between the LED anode and cathode.

**CAUTION:**

Care should be taken not to exceed the maximum output power dissipation, maximum case temperature, and maximum junction temperature when repetitively switching loads.

Micropac Industries cannot assume any responsibility for any circuits shown or represent that they are free from patent infringement. Micropac reserves the right to make changes at any time in order to improve design and to supply the best product possible.

Case Outlines	P, X and Y	
Terminal number	Terminal symbol	
	Connection A (AC or DC load)	Connection B (DC load only)
1	NC	NC
2	V <sub>F+</sub>	V <sub>F+</sub>
3	V <sub>F-</sub>	V <sub>F-</sub>
4	NC	NC
5	V <sub>O-</sub>	V <sub>O+</sub>
6	NC	NC
7	NC	N <sub>O-</sub>
8	V <sub>O+</sub>	N <sub>O+</sub>

NC = No Connection

CONNECTION A  
AC/DC CONNECTION

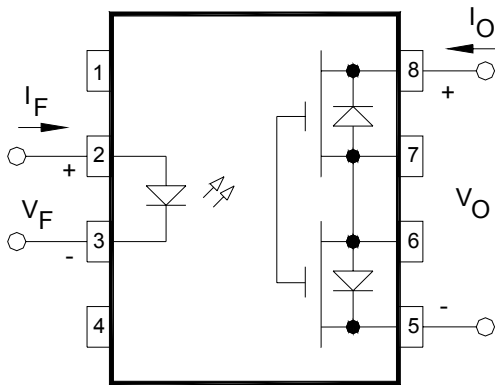

CONNECTION B  
DC CONNECTION

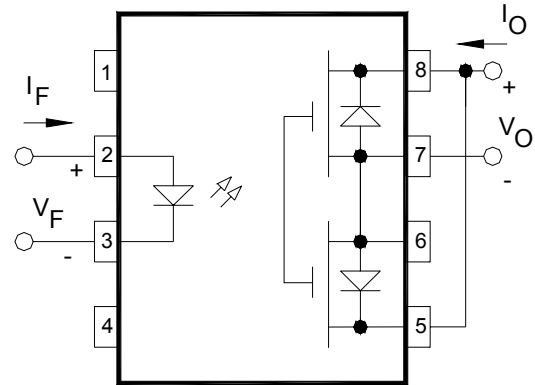

Figure 1 - Terminal Connections

INPUT	OUTPUT
OFF	OFF
ON	ON

Figure 2 - Truth Table

Micropac Industries cannot assume any responsibility for any circuits shown or represent that they are free from patent infringement. Micropac reserves the right to make changes at any time in order to improve design and to supply the best product possible.

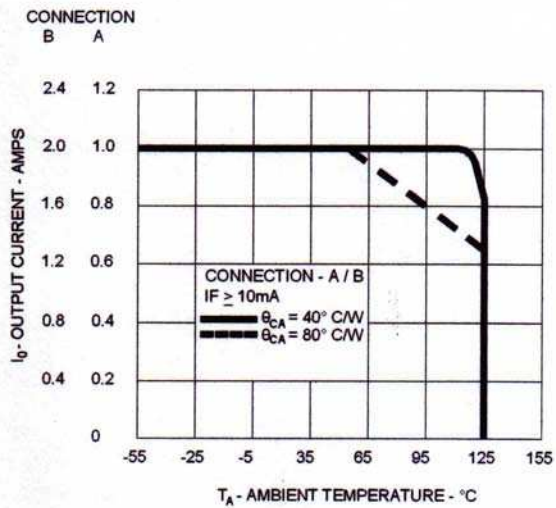

Figure 3. Maximum Average Output Current Rating vs. Ambient Temperature.

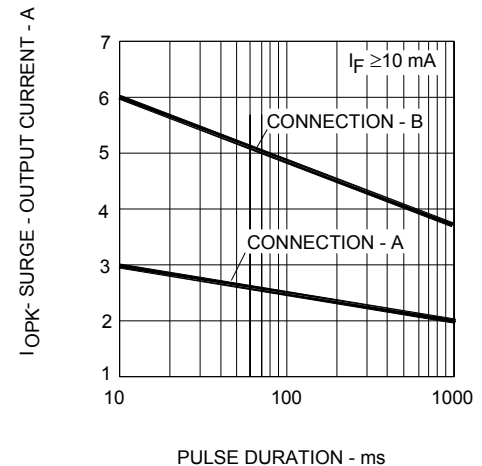

Figure 4. Single Shot (non-repetitive) Output Current vs. Pulse Duration.

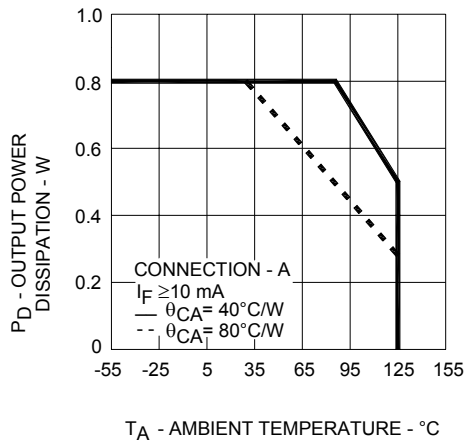
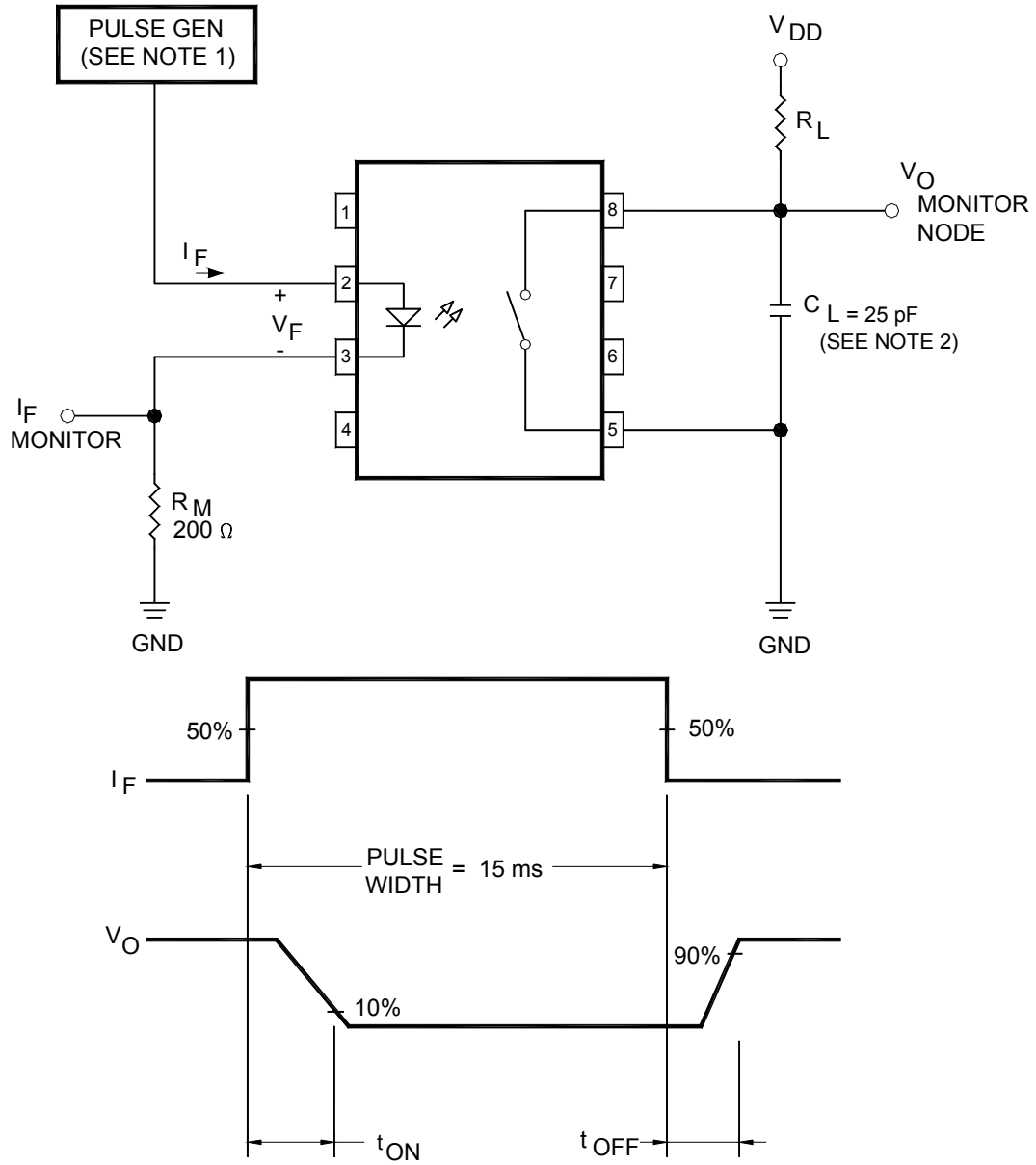

Figure 5. Output Power Rating vs. Ambient Temperature.

Micropac Industries cannot assume any responsibility for any circuits shown or represent that they are free from patent infringement. Micropac reserves the right to make changes at any time in order to improve design and to supply the best product possible.



- NOTES:
1. PULSE GENERATOR HAS THE FOLLOWING CHARACTERISTICS: OUTPUT IMPEDANCE = 50  $\Omega$  AND  $t_r = t_f = 5.0 \text{ ns}$ .
  2. LOAD CAPACITANCE ( $C_L$ ) INCLUDES PROBE AND JIG CAPACITANCE.

Figure 6. Switching Test Circuit and Waveform.

Micropac Industries cannot assume any responsibility for any circuits shown or represent that they are free from patent infringement. Micropac reserves the right to make changes at any time in order to improve design and to supply the best product possible.

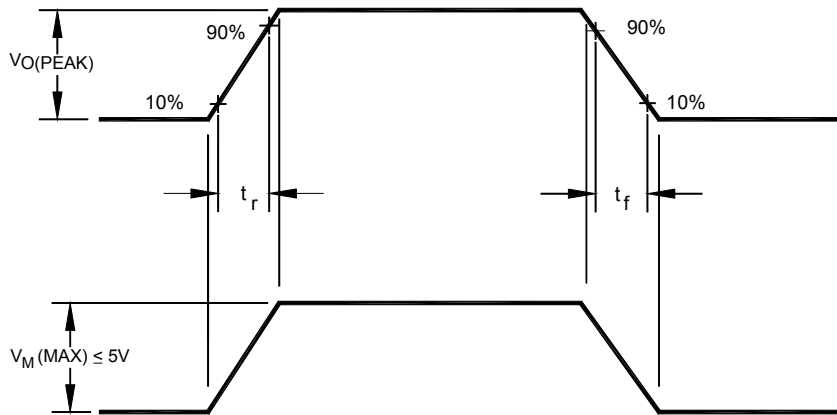
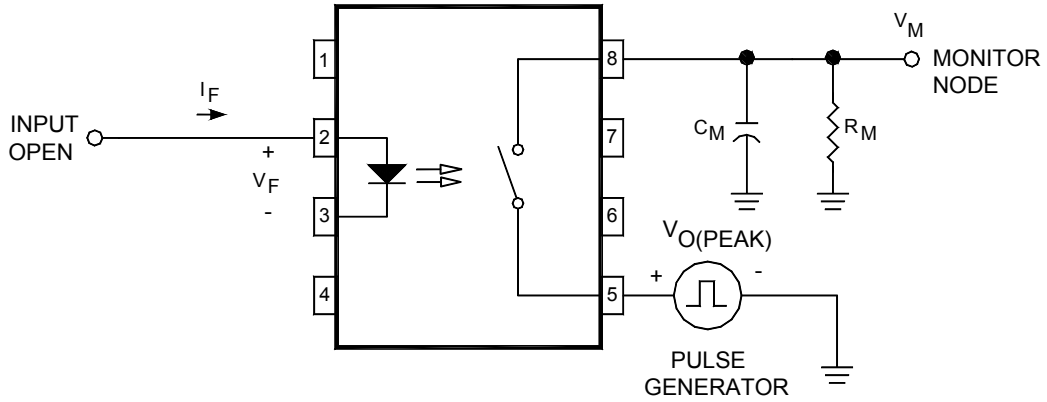

$$\frac{dV_O}{dt} = \frac{(0.8)V_O(PEAK)}{t_r} \quad \text{OR} \quad \frac{(0.8)V_O(PEAK)}{t_f}$$

OVERSHOOT ON  $V_O(PEAK)$  IS TO BE  $\leq 10\%$

NOTES:

1.  $C_M$  INCLUDES PROBE AND FIXTURE CAPACITANCE.
2.  $R_M$  INCLUDES PROBE AND FIXTURE RESISTANCE.

Micropac Industries cannot assume any responsibility for any circuits shown or represent that they are free from patent infringement. Micropac reserves the right to make changes at any time in order to improve design and to supply the best product possible.

Package Dimensions

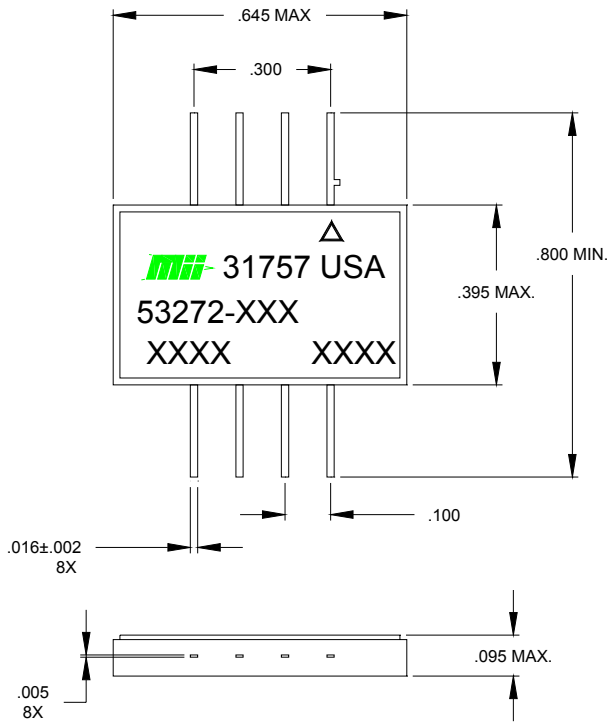

Ordering Information

53272E	Engineering Unit Non-Rad Version
53272-102	ETU Rad Version No Screening
53272-108	Rad Version Screened to H + PIND
53272-XXX	TBD

Micropac Industries cannot assume any responsibility for any circuits shown or represent that they are free from patent infringement. Micropac reserves the right to make changes at any time in order to improve design and to supply the best product possible.