

53274

**Solid State Relay
SPST, 90VDC – 10A**



<p>Features:</p> <ul style="list-style-type: none"> • Hermetically Sealed in Surface Mount Package • Low On-resistance • 10A Continuous Output Current • Performance over -55°C to +125°C • Optically Coupled • Input/Output Isolation Tested to 1000 VDC • Shock and Vibration Resistant 	<p>Applications:</p> <ul style="list-style-type: none"> • Military/High Reliability Systems • Power Distribution/Switching • Solenoid Driver • Stepper Motor Driver • Heater Switching
---	--

DESCRIPTION

The 53274 is a Power MOSFET Optocoupler designed for military applications. This light-weight device is resistant to damage from severe shock and vibration, and is immune to contact related problems inherent in electro-mechanical relays. The device is enclosed in a hermetic metal package to ensure reliability in harsh environments. Effective isolation of 1000 VDC between control and load circuits is achieved through the use of optical coupling.

Functionally, the device operates as a single-pole single-throw, normally open (1 Form A) DC solid-state relay. The SSR is actuated by an input current of 5 to 15 mA, which can be supplied from standard logic types such as open-collector TTL. Output is provided by a power MOSFET exhibiting very low $R_{DS(ON)}$ and capable of carrying a continuous current of 10 amperes. The basic data sheet part is environmentally screened to H level in accordance with Table C-IX of MIL-PRF-38534.

ABSOLUTE MAXIMUM RATINGS

Output Voltage.....	90 VDC
Continuous Output current.....	10 A
Peak Output Current ⁽¹⁾	22 A
Storage Temperature Range.....	-65°C to +150°C
Operating Junction Temperature.....	-55°C to +150°C
Lead Solder Temperature for 10 seconds.....	300°C
Continuous Input Current.....	20 mA
Peak Input Current ⁽²⁾	100 mA
Reverse Input Voltage.....	6 VDC
Power Dissipation ⁽³⁾25 W
Linear Derating Factor.....	0.2 W/°C

WEIGHT: 4.2 grams (typical)

Micropac Industries cannot assume any responsibility for any circuits shown or represent that they are free from patent infringement. Micropac reserves the right to make changes at any time in order to improve design and to supply the best product possible.

RECOMMENDED OPERATING CONDITIONS:

Parameter	Symbol	Min.	Max.	Units
Output Voltage	$V_{O(OFF)}$		90	VDC
Continuous Output Current	$I_{O(ON)}$		10	A
Input Current (on)	$I_{F(ON)}$	5	20	mA
Input Voltage (off)	$V_{F(OFF)}$	0	1	VDC
Operating Case Temperature	T_C	-55	125	°C

ELECTRICAL SPECIFICATIONS (Pre-Irradiation)

$T_C = -55^\circ\text{C}$ to $+125^\circ\text{C}$ unless otherwise specified

Parameter	Sym.	Min.	Typ.*	Max.	Units	Test Conditions	Notes
Output On-Resistance	$R_{(ON)}$	—	0.055	0.100	Ω	$I_F = 15\text{ mA}$ $I_O = 10\text{ A}$ Pulse width = 15 ms Duty cycle $\leq 1\%$	
Output Leakage Current	$I_{O(OFF)}$	—	<1	250	μA	$V_F = 1\text{ VDC}$ $V_O = 90\text{ VDC}$	
Input Forward Voltage	V_F	2.45	3.75	4.50	VDC	$I_F = 10\text{ mA}$	
Input Reverse Breakdown Voltage	V_R	6	40	—	VDC	$I_R = 10\ \mu\text{A}$	
Input-Output Leakage	I_{I-O}	—	—	1	μA	$RH \leq 45\%$, $t = 5\text{ s}$ $V_{I-O} = 1000\text{ VDC}$ $T_C = 25^\circ\text{C}$	4, 5
Turn-On Time	t_{ON}	—	3.3	8.0	ms	$I_F = 15\text{ mA}$ $I_O = 10\text{ A}$ Pulse width = 15 ms Duty cycle $\leq 1\%$	Figures 3, 4
Turn-Off time	t_{OFF}	—	0.35	2	ms		Figures 3, 5
Rise Time	t_R	—	2.5	6.0	ms		6, Figure 3
Fall Time	t_F	—	0.19	1.0	ms		
Thermal Resistance (junction-case)	θ_{JC}	—	4	—	°C/W		
Output Off-Capacitance	$C_{O(OFF)}$	—	1.7	—	nF	$V_O = 28\text{ VDC}$ $f = 1\text{ MHz}$	
Input Capacitance	C_{IN}	—	27	—	pF	$V_F = 0\text{ V}$ $f = 1\text{ MHz}$	
Input-Output Capacitance	C_{I-O}	—	2.6	—	pF	$V_{I-O} = 0\text{ V}$ $f = 1\text{ MHz}$	4

* All typical values are at $T_C = 25^\circ\text{C}$

Micropac Industries cannot assume any responsibility for any circuits shown or represent that they are free from patent infringement.
Micropac reserves the right to make changes at any time in order to improve design and to supply the best product possible.

Notes:

1. Non-repetitive, pulse width $\leq 10\text{ms}$, $T_C = 25^\circ\text{C}$ (see Figure 6).
2. Non-repetitive, pulse width $\leq 100\mu\text{s}$, $T_C = 25^\circ\text{C}$.
3. Case Temperature $T_C = 25^\circ\text{C}$ (see Figure 7).
4. Input pins shorted together and output pins shorted together.
5. Input-output potential applied momentarily, not an operating condition.
6. Rise time is measured from 10% to 90% of load current (90% to 10% of V_O). Fall time is measured from 90% to 10% of load current (10% to 90% of V_O).

CAUTION:

Care should be taken so as not to exceed the maximum power dissipation and maximum junction temperature when repetitively switching loads.

INPUT	OUTPUT
ON	ON
OFF	OFF

Figure 1. Truth Table

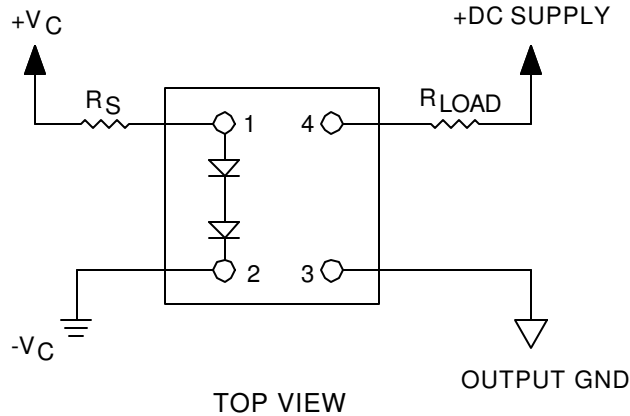

Figure 2. Terminal Connections

Micropac Industries cannot assume any responsibility for any circuits shown or represent that they are free from patent infringement. Micropac reserves the right to make changes at any time in order to improve design and to supply the best product possible.

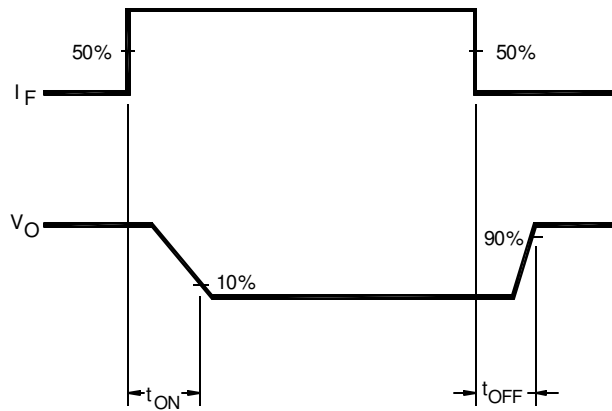
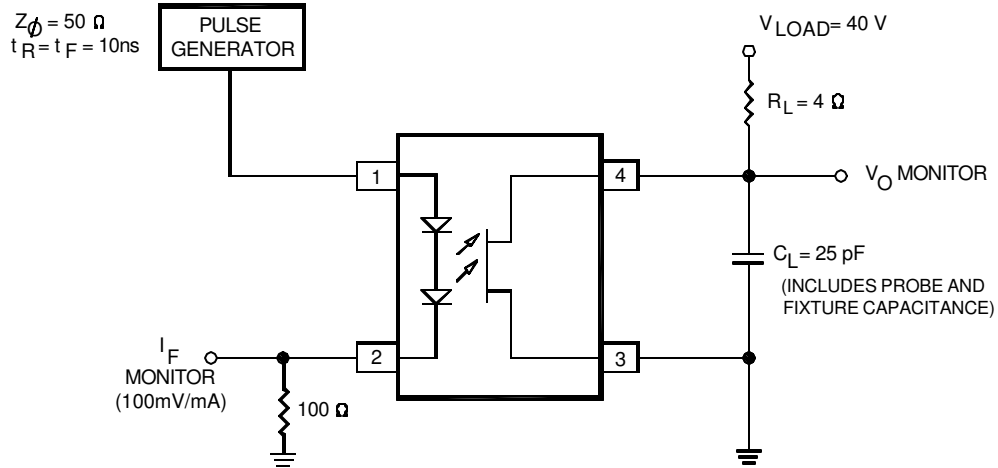

Figure 3. Switching Waveforms and Test Circuits

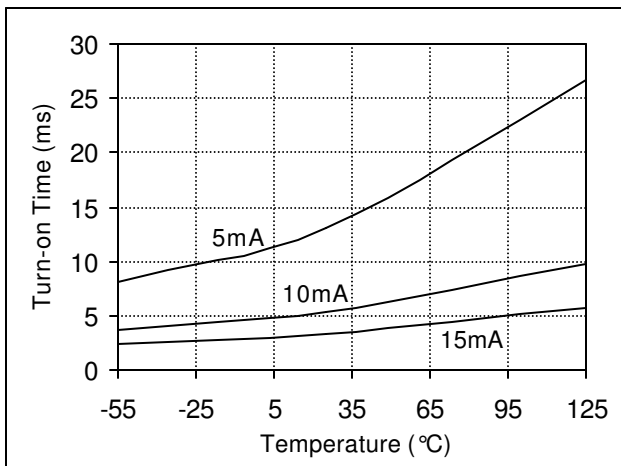

Figure 4. Turn-on Time vs. Case Temperature for Different Values of I_F (typical data).

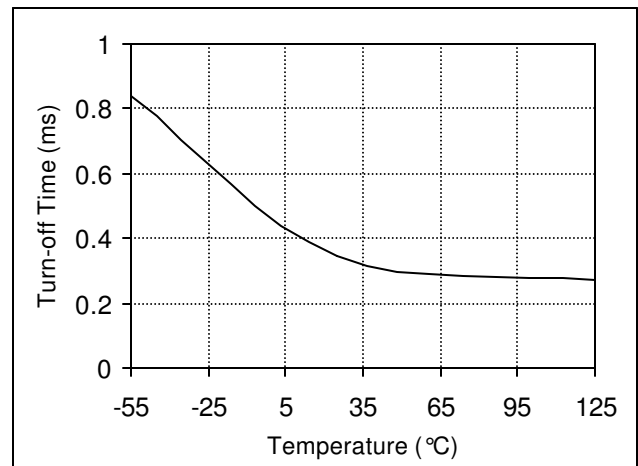

Figure 5. Turn-off Time vs. Case Temperature with $I_F = 5$ to 15 mA (typical data).

Micropac Industries cannot assume any responsibility for any circuits shown or represent that they are free from patent infringement. Micropac reserves the right to make changes at any time in order to improve design and to supply the best product possible.

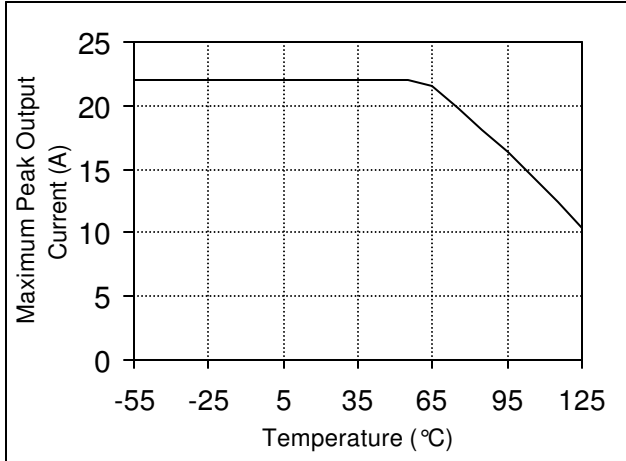

Figure 6. Maximum Non-repetitive Output Current vs. Case Temperature (pulse width ≤ 10 ms).

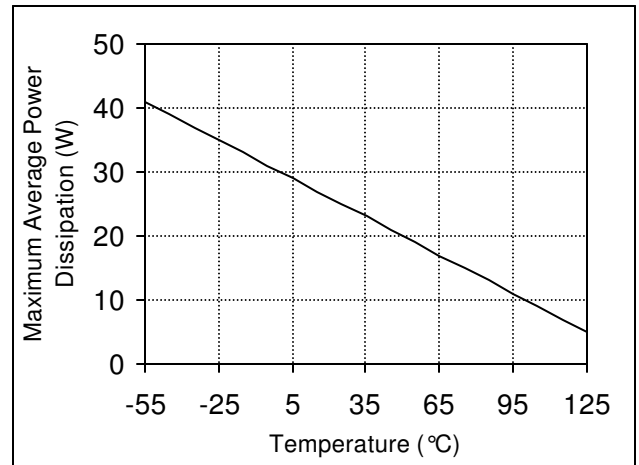
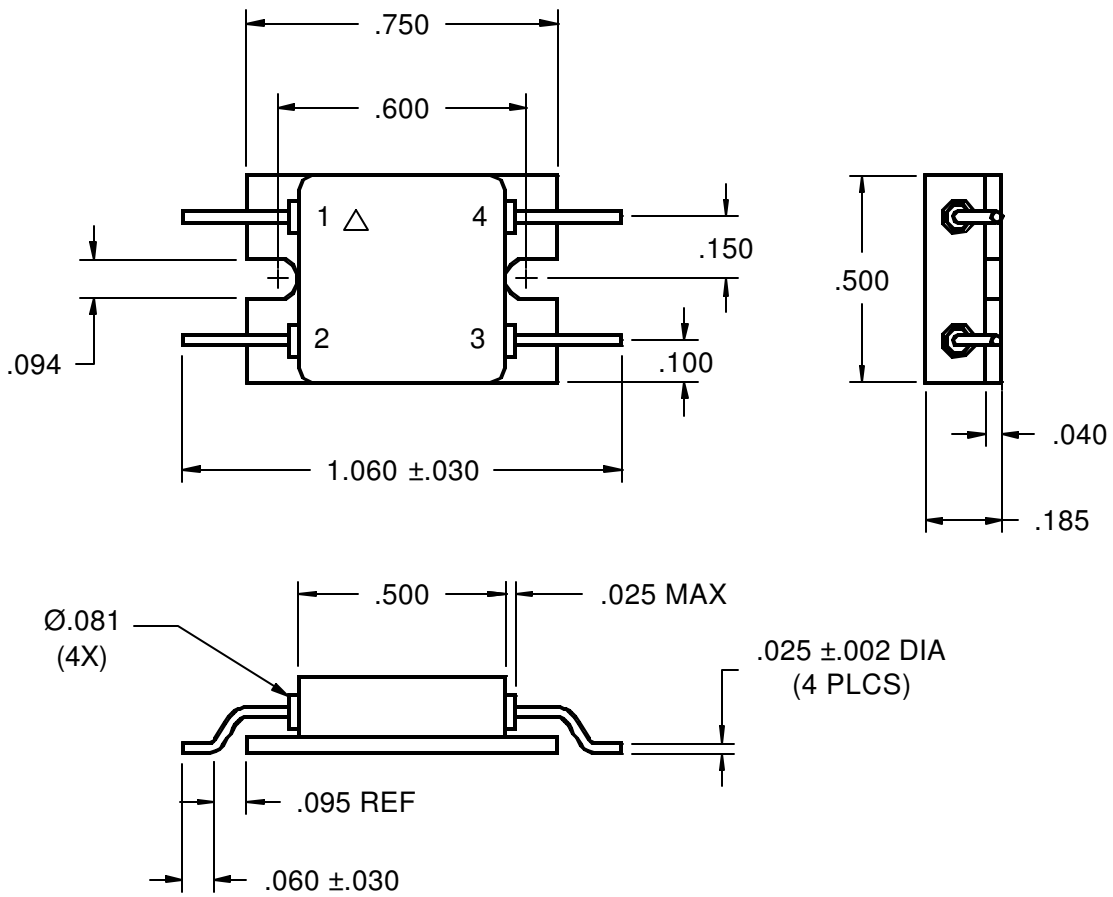

Figure 7. Maximum Average Output Power Dissipation vs. Case Temperature.

CASE OUTLINE



Micropac Industries cannot assume any responsibility for any circuits shown or represent that they are free from patent infringement. Micropac reserves the right to make changes at any time in order to improve design and to supply the best product possible.