

53503

**LATCHING, ISOLATED OUTPUT SOLID
STATE POWER CONTROLLERS**

Mii

MICROCIRCUITS DIVISION

Features:

- Switch Status Output
- I²T circuit protection with status output
- SPST, normally open
- 5A, 10A and 15A Operating Current
- Power FET output with Low on-state resistance
- Full military temperature operation: -55°C to +125°C.
- Radiation hardened capable.
- Military environmental screening available

Applications:

- Designed for 24V, 150V and 270V bus applications
- Aircraft Power Distribution
- Military/High Reliability Systems
- Satellite/Space Systems

DESCRIPTION

The 53503 Solid-State Power Controllers are lightweight, resistant to damage from shock and vibration, and immune to contact-related problems (contamination, arcing) associated with mechanical equivalents.

Transformer coupling between the input, output and Power Bus stages provides effective isolation of 1000 V RMS. The Power FET output eliminates bipolar offset and minimizes output voltage drop.

The Control input is CMOS or TTL logic compatible and may operate from a bias supply of 4.5 to 5.5VDC. (See Figure 1)

Integral short-circuit protection, I²T trip and output status is provided. The output current flow is continuously monitored and responds to an over-current condition with an I²T trip curve by opening the output. Over-current conditions include Over-Load and Shorted Output during Turn-On. An open-collector Fault Status or Output Status (optional) is available to indicate the fault or switch state. The output remains blocked until the short is removed and the unit reset. This feature prevents damage to the controller while averting further system failures that may be caused by the short circuit. Standard Output Fault is an Active Low output remaining high (open) under all operating conditions except during an Output Fault. The optional Output Status is High when the output is On and Low when the output is Off. Resetting the unit is accomplished by recycling the input control.

This device is available in various quality levels from COTS to class K including any custom screening requirements. All components have radiation-hardened equivalents. The basic data sheet part is environmentally screened to H level in accordance with Table C-IX of MIL-PRF-38534 with no element evaluation or QCI.

ABSOLUTE MAXIMUM RATINGS

Isolation voltage ¹	1000 V RMS
Continuous operating output voltage ²	100, 200, 400 or 500 VDC
Transient output voltage ³	100, 200, 400 or 500 VDC
Load Current.....	Less Than 8 Times Rated Operating Current / Self Limiting
Bias supply voltage, V _{DD}	-6 to 5.5 VDC
Power Bias supply voltage.....	400 VDC
Control Voltage.....	1 Volt above V _{DD} / Volt below Return
Operating temperature.....	-55°C to +125°C Case
Storage temperature.....	-55°C to +125°C

Notes:

- ¹ 60 Hz sine wave
- ² Reversing polarity on the output may cause permanent damage
- ³ Device rating. Application derating not included in these values

<p>Micropac Industries cannot assume any responsibility for any circuits shown or represent that they are free from patent infringement. Micropac reserves the right to make changes at any time in order to improve design and to supply the best product possible.</p>

ELECTRICAL CHARACTERISTICS

 $T_A = -55$ to 125°C

PARAMETER	TEST CONDITIONS	MIN	TYP	MAX	UNITS
Input characteristics					
CMOS configurations (Figure 1)					
Bias supply range, V_{DD}		3.0	5.0	5.5	VDC
Bias current			3	10	mA
Input current	5 VDC Input			500	μA
Control voltage range		-0.5		6.0	VDC
Turn-on voltage			2.8	3.2	VDC
Turn-off voltage		0.5	2.7		VDC
Dielectric strength	60 Hz / Input /output / Power Bus/ Case	1000			V RMS
Output characteristics					
Power Bus Supply (Note 1)	24 to 400 VDC		10	20	mA
Output current, sustaining:	Steady state load Current Whichever is less	20% 3A			% ADC
Load Start current (not adjusted)	Current factor above sustaining 0 to 100ms	600		900	%
Output Pass Current adjustment range:	0 to 100ms	100		50	% of Initial
Continuous blocking voltage	Output device Rating			Rating	VDC
On-state resistance, R_{ds}	25°C Case (Table 1)				Ohms
On-state resistance, R_{ds}	125°C Case (Table 1)				Ohms
Turn-on time @ 25°C case	Figure 2		1.0	3.0	mS
Turn-off time @ 25°C case	Figure 2		1.0	3.0	mS
Off-state leakage	At Maximum Blocking Voltage		100	300	μA
Output Capacitance				3,000	pF
Status Output Specification					
Trip Reset Time	Remove overload & Cycle input	50			mS
Status Supply Voltage (open Collector)		5.0		32	VDC
Status off leakage current	$V_S = 15$ VDC			4	μADC
Status on voltage	$I_{STATUS} = 5$ MA @ 25°C			0.4	VDC
High-To-Low Transition Time	$I_{STATUS} = 5$ MA		20	50	μS
Junction temperature					
Thermal resistance, θ_{JA}				150	$^\circ\text{C/W}$
Thermal resistance, θ_{JC}				30	$^\circ\text{C/W}$
				5	$^\circ\text{C/W}$

APPLICATION NOTES:

1. Maximum input switching frequency not to exceed 20 Hz under normal conditions, or into a shorted output.
2. Input transitions should be "bounceless contact" with transitions of <1 ms.
3. Inductive loads must be suppressed.

Micropac Industries cannot assume any responsibility for any circuits shown or represent that they are free from patent infringement.
Micropac reserves the right to make changes at any time in order to improve design and to supply the best product possible.

	5A Sustaining	10A Sustaining	15A Sustaining
100 VDC Units	30 / 40 mΩ	18 / 25 mΩ	14 / 22 mΩ
200 VDC Units	40 / 60 mΩ	24 / 38 mΩ	18 / 26 mΩ
400 VDC Units	90 / 160 mΩ	60 / 110 mΩ	See 53504
500 VDC Units	110 / 200 mΩ	80 / 150 mΩ	See 53504

TABLE 1
25°C / 125°C R_{ds} On Vales by Unit Voltage and Current Rating.

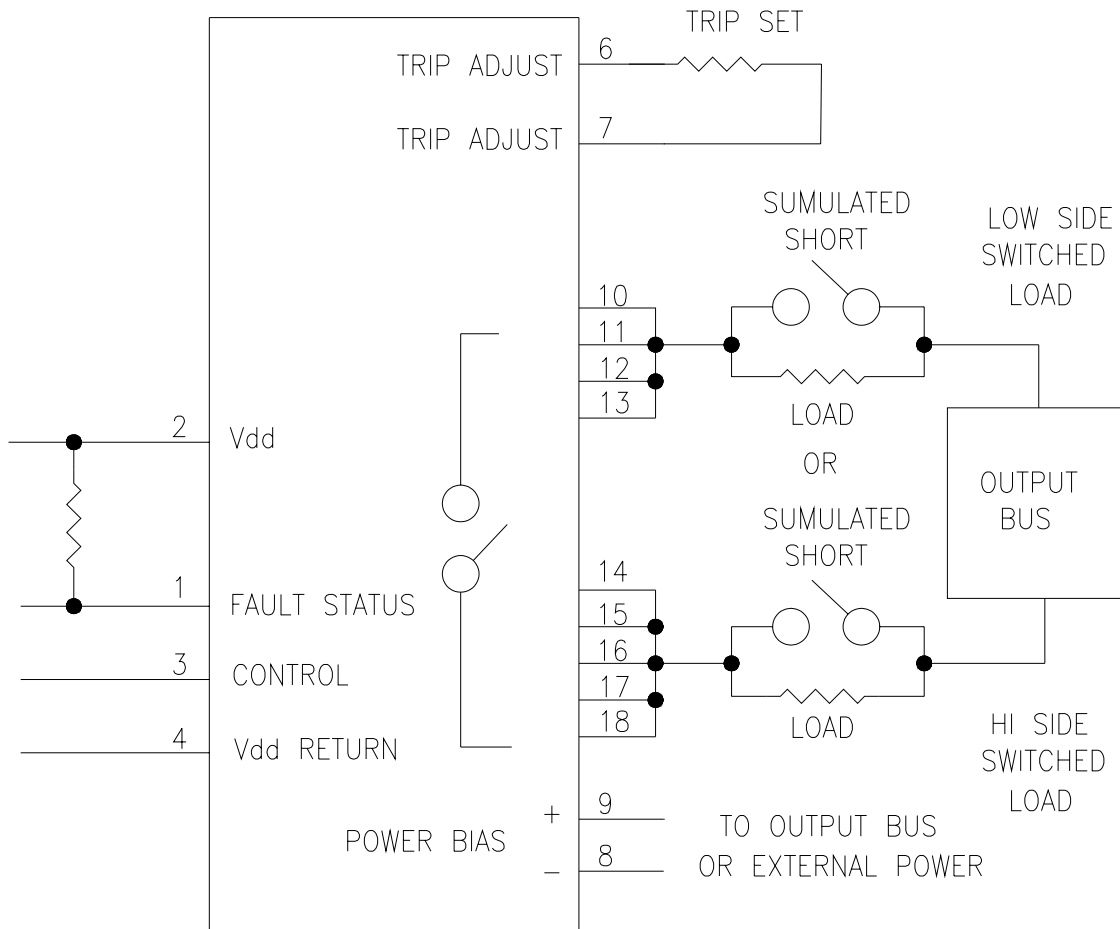

FIGURE 1
High or Low side isolated switch connection. Full isolation exists between Input Logic and status, Output Switch connects, Power Bias and Case.

Micropac Industries cannot assume any responsibility for any circuits shown or represent that they are free from patent infringement. Micropac reserves the right to make changes at any time in order to improve design and to supply the best product possible.

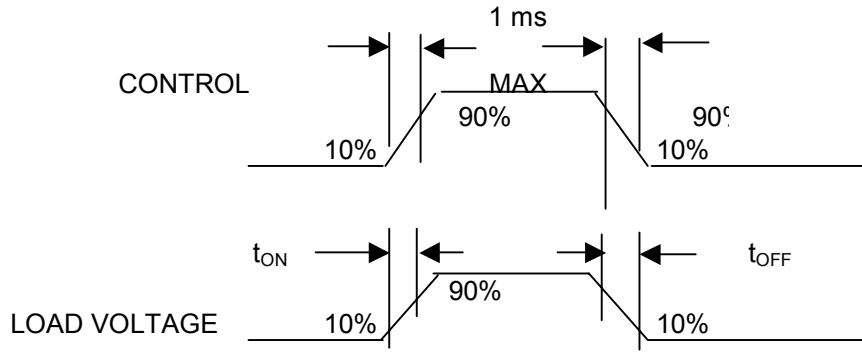

Figure 2 Switching Characteristics

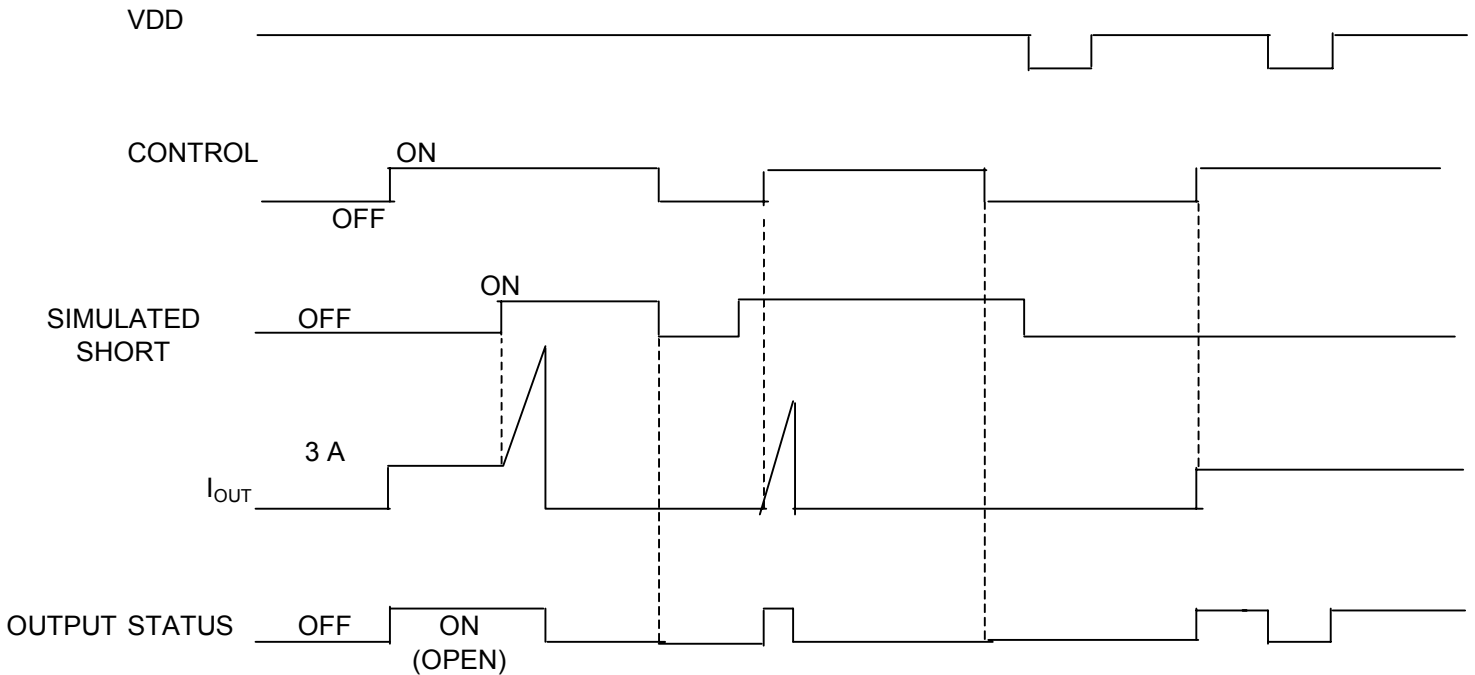

Figure 3 - TIMING DIAGRAM

Note 1: A turn-off into a short produces an increase in current to the initial I²T must trip value.

Note 2: Shorted while On from any On operating condition can have a μ s surge current of as much as 100A.

Note 3: Loss of and re-application of Bus power will result in a re-start (output open & Output Status low.)

Note 4: Output Status signal assumes a pull-up voltage is always present to produce a "1" when status is open.

Micropac Industries cannot assume any responsibility for any circuits shown or represent that they are free from patent infringement. **Micropac** reserves the right to make changes at any time in order to improve design and to supply the best product possible.

Truth Table – Power Sequencing

Bus Voltage	0	On	0			On	On
V_{DD}	0	0	On				
Control	X	X	X	0		X	X
I Out	Open	Open	Open	Open		0	1
Output Status	Open “1”	Open “1”	0	0			Open “1”
Short	X	X	X	Off	Off	Off	Off
		(Note 1)	(Note 1,2)	(Note 3)	(Note 3,4)	(Note 5)	(Note 5)

Truth Table – Short circuit and Status

	Turn on into Short Sequence					Short while on Sequence				
Control	0	1	1	0	1	1	1	1	0	1
I out	Off	Off	Off	Off	On	On	Off	Off	Off	On
Output Status	0	0	0	0	Open “1”	Open “1”	0	0	0	Open “1”
Shorted Output	Shorted	Shorted	X	Off	Off	Off	On	X	X	Off

Note 1: Unit Powers up in the Off condition with application of either Bus power or V_{DD}.

Note 2: Fault Status reports only when V_{DD} is present.

Note 3: Control “0” Off must be invoked upon simultaneous applications of 5V and Bus Power for an unambiguous output and fault status.

Note 4: An Off Control to On Control transition is required to first turn the Unit On.

Note 5: Loss of V_{DD} will not change output state during normal operation.

Note 6: Truth Table Power sequencing: Output Status open collector pull-up resistor is assigned a separate and always present voltage, producing a “1” when “Open”.

Micropac Industries cannot assume any responsibility for any circuits shown or represent that they are free from patent infringement. Micropac reserves the right to make changes at any time in order to improve design and to supply the best product possible.

Package Dimensions

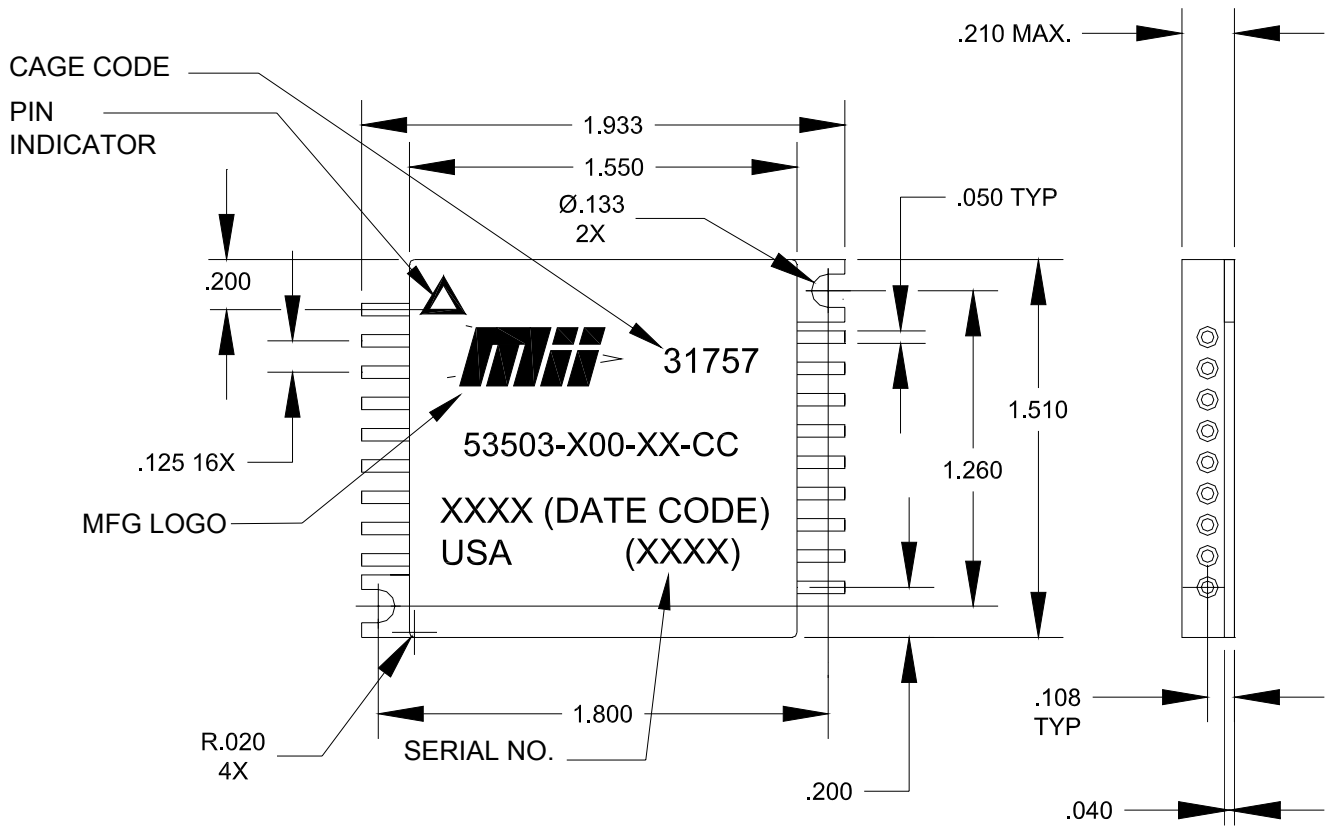

IN	FUNCTION
1	FAULT STATUS
2	V _{DD}
3	CONTROL
4	CONTROL RETURN
5	NO CONNECTION
6, 7	TRIP CURRENT ADJUST
8	POWER BIAS RETURN
9	POWER BIAS
10, 11, 12, 13	+ BUS
14, 15, 16, 17, 18	OUTPUT

Micropac Industries cannot assume any responsibility for any circuits shown or represent that they are free from patent infringement. Micropac reserves the right to make changes at any time in order to improve design and to supply the best product possible.

NOTES:

- 1) Initial current limits, NO TRIP and MUST TRIP, will be 500% and 900%, respectively above the rated operating current.
- 2) I_R – Rated Operating Current.
- 3) Two times rated operating current.
- 4) Minimum output current (sustaining) is 20% or 1Amp above I_R , whichever is greater.

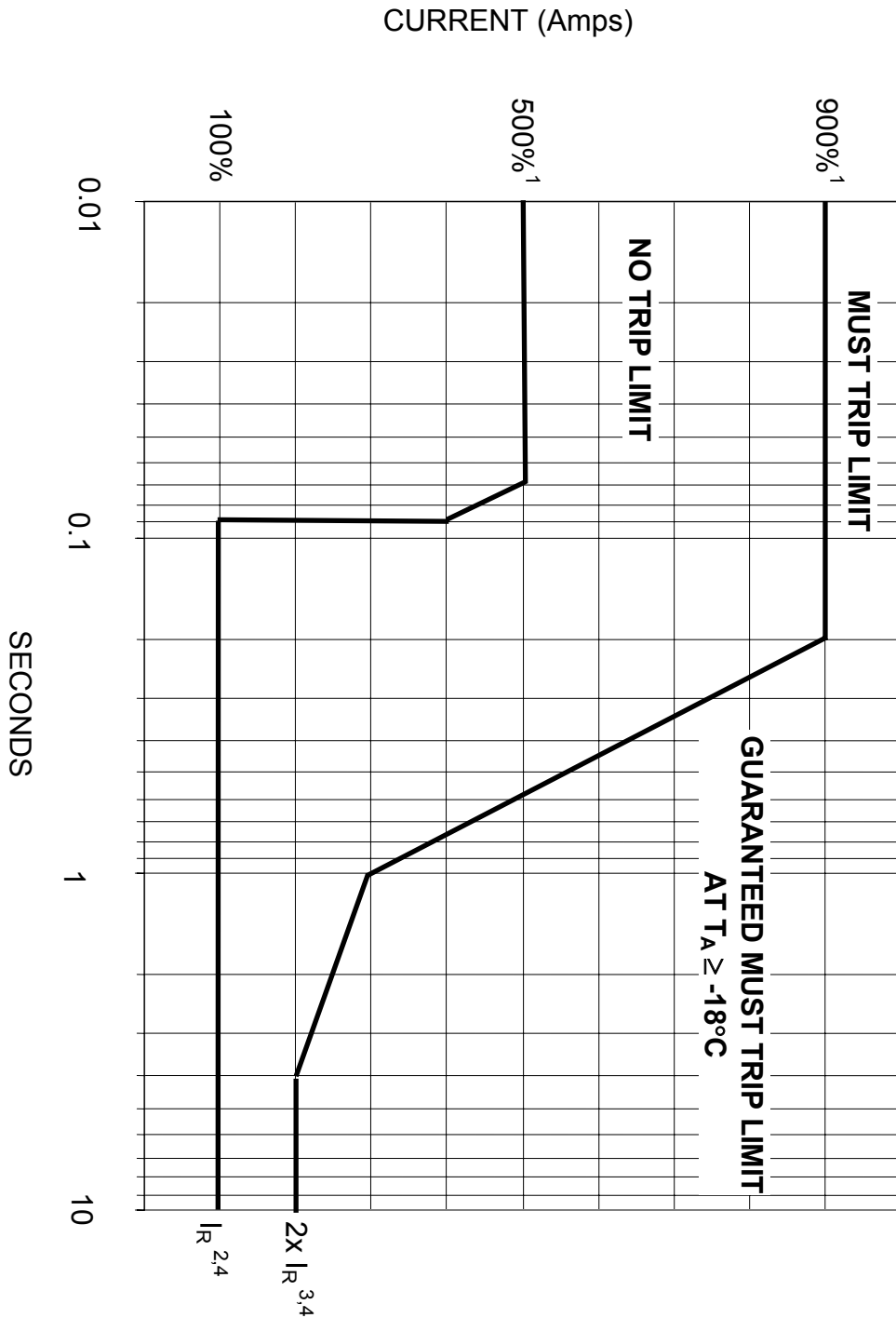

Micropac Industries cannot assume any responsibility for any circuits shown or represent that they are free from patent infringement. Micropac reserves the right to make changes at any time in order to improve design and to supply the best product possible.

Ordering Information:

MPC-53503-XXX-XX-XX

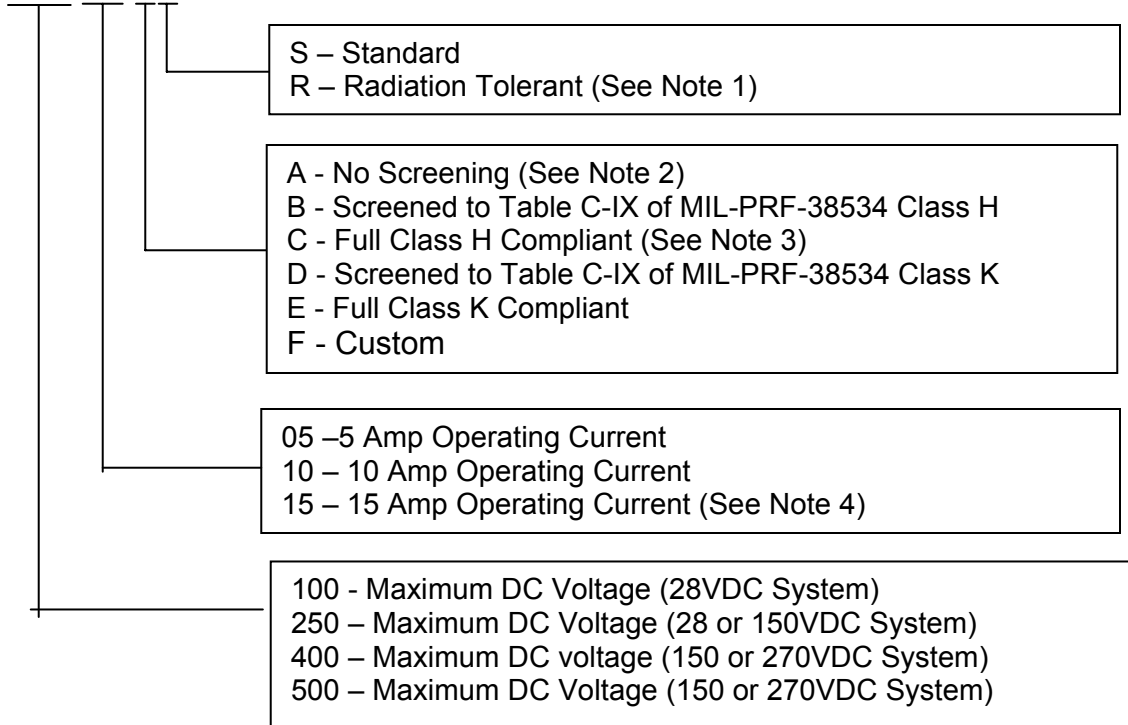

NOTES:

1. Devices are radiation tolerant by design but are not lot tested. Micropac does not guarantee performance to any radiation level. Individual lots must be tested to guarantee performance.
2. Devices are electrically tested at -55°C, +25°C and +125°C with no environmental screening or qualification.
3. Fully compliant Class H or Class K devices will require Element Evaluation and QCI.
4. The 53503 SSPC will support 15 Amp Operating Current up to 200 Volts (max.) For voltage and current requirements above this level please refer to the 53504 datasheet.

Micropac Industries cannot assume any responsibility for any circuits shown or represent that they are free from patent infringement. Micropac reserves the right to make changes at any time in order to improve design and to supply the best product possible.