

53278

**28 V HIGH SIDE LATCHING SOLID-STATE
POWER CONTROLLER**



Features:

- Switch Status Output
- I²T circuit protection
- SPST, normally open
- 1A , 2A Pin Configurable Operating Current
- Power FET output with Low on-state resistance
- Full military temperature operation:
-55°C to +125°C.
- Radiation hardened capable.
- Military environmental screening available

Applications:

- Ideal for 24V bus applications
- Aircraft Power Distribution
- Military/High Reliability Systems
- Satellite/Space Systems

DESCRIPTION

The 53278 is a military SPST, solid-state relay. It is a lightweight device resistant to damage from shock and vibration, and immune to contact-related problems (contamination, arcing) associated with mechanical equivalents.

Transformer coupling between the input and output stages provides effective isolation up to 1000 V RMS. The Power FET output eliminates bipolar offset and minimizes output voltage drop.

The preferred control input is CMOS compatible operating from a bias supply of 4.5 to 5.5VDC. (See Figure 1)

Integral short-circuit protection, I²T trip and status output is provided. This unit is Pin configurable for 1A or 2A output. The output current flow is sensed while under load or while switching, and responds to an over-current with an I²T trip curve by opening the output. An open-collector Status is available to indicate the switch state. The output will remain blocked indefinitely until the short is removed and the unit reset. This feature prevents damage to the controller and also averts further system failures that may be caused by the short circuit. Output Status is On (High) when the output is switched on and is Off (Low) whenever the output is commanded off or tripped. Resetting the unit is accomplished by recycling the input control.

This device is available in a variety of quality levels from COTS to class K including any custom screening requirements and all components have radiation-hardened equivalents. The basic data sheet part is environmentally screened to H level in accordance with Table C-IX of MIL-PRF-38534 with no element evaluation or QCI.

ABSOLUTE MAXIMUM RATINGS

Isolation voltage ¹	1000 V RMS
Continuous operating output voltage ²	50 VDC
Transient output voltage.....	60 VDC
Load Current.....	18A / Self Limiting
Bias supply voltage, V _{DD}	4.5 to 5.5 VDC
Operating temperature	-55°C to +125°C Case
Storage temperature	-55°C to +125°C

Notes:

¹ 60 Hz sine wave

² Reversing polarity on the output may cause permanent damage

Micropac Industries cannot assume any responsibility for any circuits shown or represent that they are free from patent infringement. **Micropac** reserves the right to make changes at any time in order to improve design and to supply the best product possible.

ELECTRICAL CHARACTERISTICS

 $T_A = +25^\circ\text{C}$

PARAMETER	TEST CONDITIONS	MIN	TYP	MAX	UNITS
Input characteristics					
CMOS configurations (Figure 1)					
Bias supply range, V_{DD}		3.3		5.5	VDC
Bias current			5	10	mA
Input current	5 VDC Input			500	μA
Control voltage range		-0.5		5.5	VDC
Turn-on voltage	At $V_{DD} = 5.0\text{V}$		2.8	3.2	VDC
Turn-off voltage	At $V_{DD} = 5.0\text{V}$	0.5	2.0		VDC
Dielectric strength	60 Hz	1000			V RMS
Bus Return Bias Current:	28V Bus Voltage		10	20	mA
Output characteristics					
Output current, sustaining:	Steady state load	1.2 / 2.4		2.4 / 4.8	A
Continuous blocking voltage				50	VDC
On-state resistance, R_{ds} (1A Configuration)	25°C Case		0.075	0.1	Ohms
On-state resistance, R_{ds} (2A Configuration)	25°C Case		0.050	0.075	Ohms
Turn-on time @ 25°C case	Figure 2		0.8	2.0	mS
Turn-off time @ 25°C case	Figure 2		0.5	1.0	mS
Off-state leakage	At Maximum Blocking Voltage		40	100	μA
Output Capacitance				700	pF
Load Start current	25°C	6/12	7.5/15	9/18	A
Short-circuit peak				100	A
Trip Reset Time	Remove short / overload & Cycle input	50			mS
Status Output Specification		5.0		32	VDC
Status Supply Voltage (open Collector)					
Status off leakage current	$V_S = 30\text{VDC}$			100	μADC
Status off leakage current	$V_S = 15\text{VDC}$			4	μADC
Status on voltage	$I_{STATUS} = 5\text{MA}$			0.4	VDC
High-To-Low Transition Time	$I_{STATUS} = 5\text{MA}$		20	50	μS
Junction temperature				150	$^\circ\text{C}$
Thermal resistance, θ_{JA}				30	$^\circ\text{C/W}$
θ_{JC}				5	$^\circ\text{C/W}$

APPLICATION NOTES:

1. Maximum input switching frequency not to exceed 20 Hz under normal conditions, or 1 Hz if output is shorted.
2. Input transitions should be $<1\text{ms}$ and duration and input source should be "bounceless contact" type.
3. Inductive loads must be suppressed.
4. Peak current that may flow when output is shorted.

Micropac Industries cannot assume any responsibility for any circuits shown or represent that they are free from patent infringement.
Micropac reserves the right to make changes at any time in order to improve design and to supply the best product possible.

Connect 6,7 or 7,8 for 1A
 Connect 6,7,8 for 2A

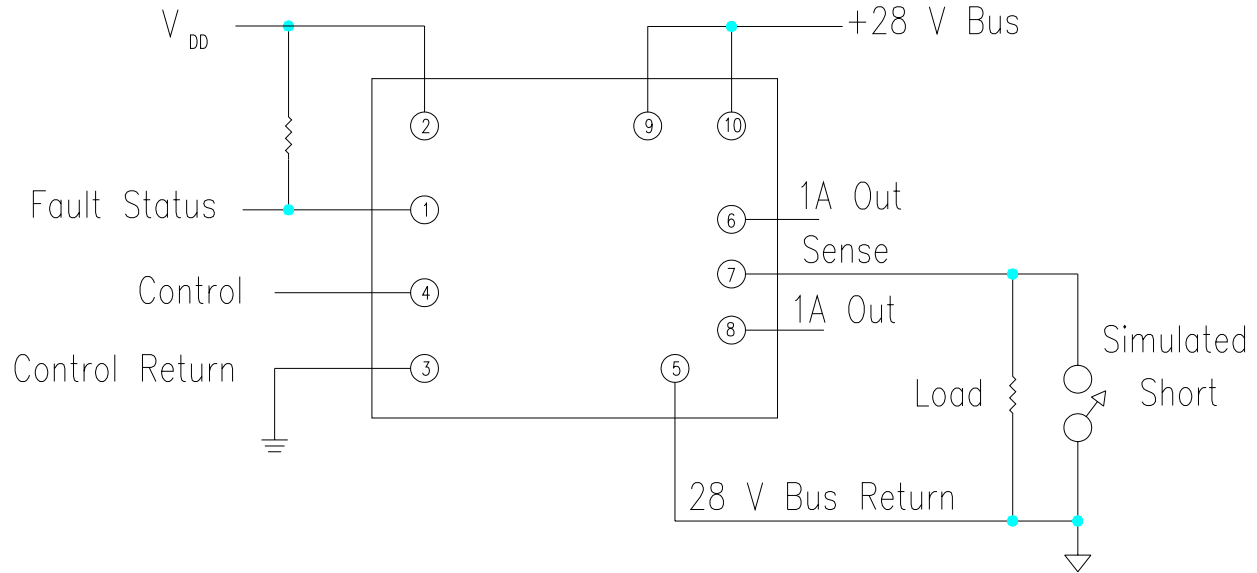

Figure 1 Typical Connection Diagram

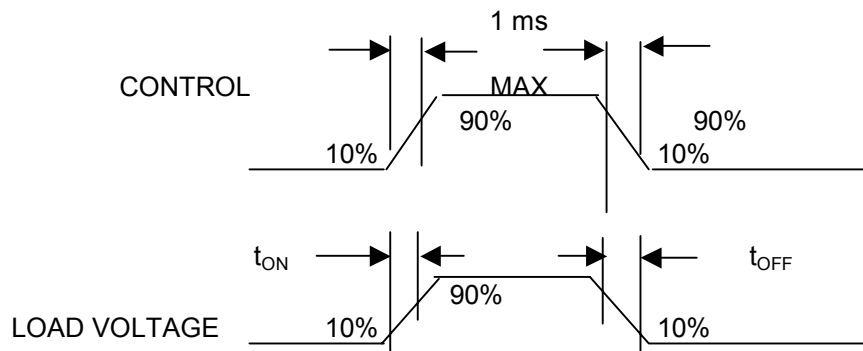

Figure 2 Switching Characteristics

Micropac Industries cannot assume any responsibility for any circuits shown or represent that they are free from patent infringement.
Micropac reserves the right to make changes at any time in order to improve design and to supply the best product possible.

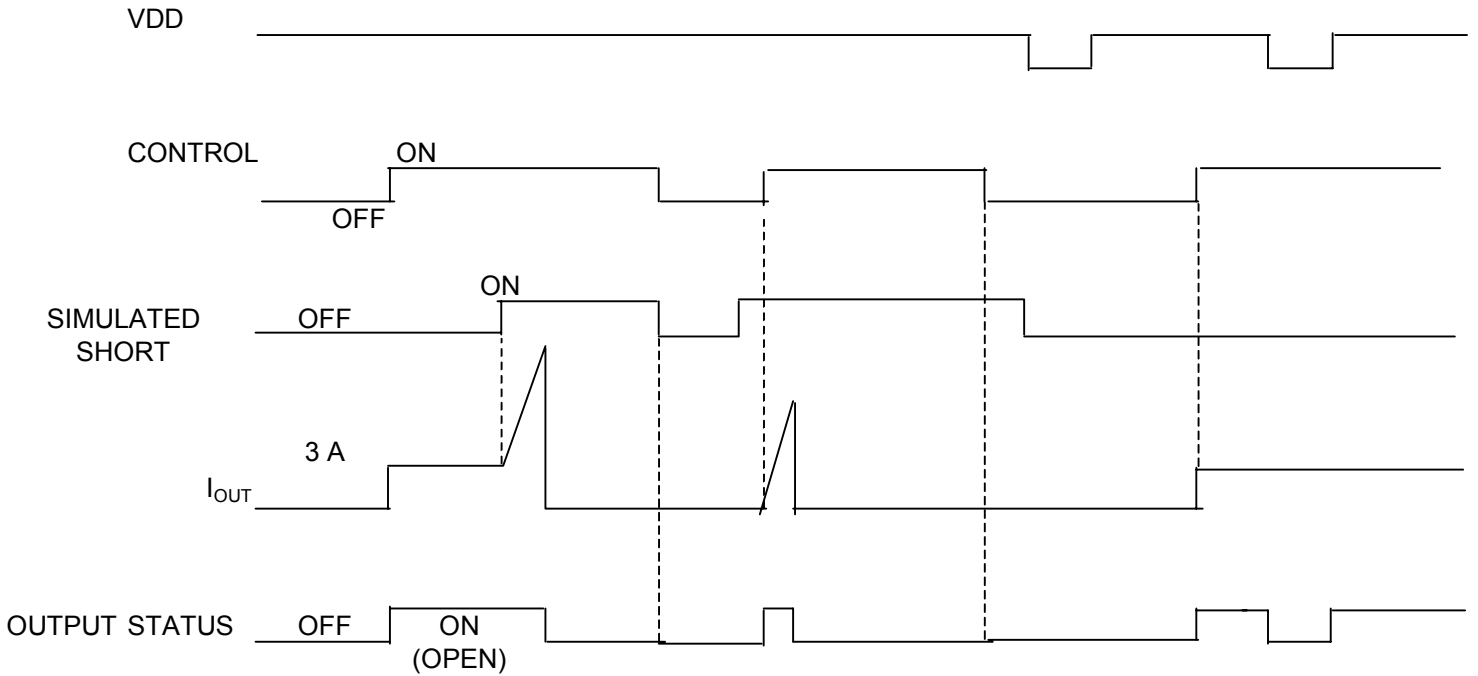

Figure 3 - TIMING DIAGRAM

Note 1: A turn-off into a short produces an increase in current to the initial I²T must trip value.

Note 2: Shorted while On from any On operating condition can have a several μs surge current of as much as 100A.

Note 3: Loss of and re-application of Bus power will result in a re-start (output open & Fault Status low.)

Note 4: Output Status signal assumes a pull-up voltage is always present to produce a "1" when status is open.

Micropac Industries cannot assume any responsibility for any circuits shown or represent that they are free from patent infringement. Micropac reserves the right to make changes at any time in order to improve design and to supply the best product possible.

Truth Table – Power Sequencing

Bus Voltage	0	On	0			On	On
V_{DD}	0	0	On				
Control	X	X	X	0		X	X
I Out	Open	Open	Open	Open		0	1
Output Status	Open "1"	Open "1"	0	0			Open "1"
Short	X	X	X	Off	Off	Off	Off
		(Note 1)	(Note 1,2)	(Note 3)	(Note 3,4)	(Note 5)	(Note 5)

Truth Table – Short circuit and Status

	Turn on into Short Sequence					Short while on Sequence				
Control	0	1	1	0	1	1	1	1	0	1
I out	Off	Off	Off	Off	On	On	Off	Off	Off	On
Output Status	0	0	0	0	Open "1"	Open "1"	0	0	0	Open "1"
Shorted Output	Shorted	Shorted	X	Off	Off	Off	On	X	X	Off

Note 1: Unit Powers up in the Off condition with application of either Bus power or V_{DD}.

Note 2: Fault Status reports only when V_{DD} is present.

Note 3: Control "0" Off must be invoked upon simultaneous applications of 5V and Bus Power for an unambiguous output and fault status.

Note 4: An Off Control to On Control transition is required to first turn the Unit On.

Note 5: Loss of V_{DD} will not change output state during normal operation.

Note 6: Truth Table-Power sequencing: Output Status open collector pull-up resistor is assigned a separate and always present voltage, producing a "1" when "Open".

Micropac Industries cannot assume any responsibility for any circuits shown or represent that they are free from patent infringement. **Micropac** reserves the right to make changes at any time in order to improve design and to supply the best product possible.

Package Dimensions

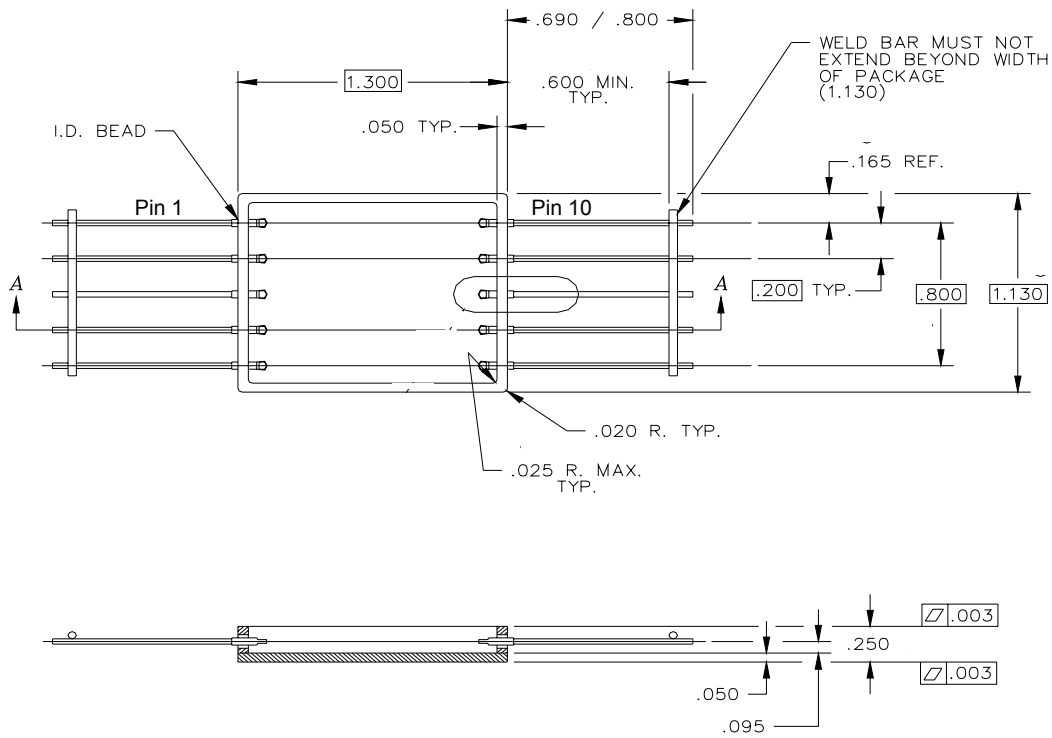

NOTES:

1. MATERIAL:
PACKAGE: ASTM F-15 ALLOY
LEADS: ASTM F-15 ALLOY BRAZED TO ZIRCONIUM COPPER.

IN	FUNCTION
1	FAULT STATUS
2	V _{DD}
3	CONTROL RETURN
4	CONTROL
5	BUS RETURN
6	OUT (1A)
7	OUT SENSE
8	OUT (1A)
9	+ BUS
10	+ OUT BUS

Note: For 1A output, connect Pins 6 and 7 or Pins 7 and 8; for 2A output connect Pins 6, 7 and 8.

Micropac Industries cannot assume any responsibility for any circuits shown or represent that they are free from patent infringement. **Micropac** reserves the right to make changes at any time in order to improve design and to supply the best product possible.

NOTES:

- 1) Initial current limits (NO TRIP and MUST TRIP) will be 6 and 9A for each of the 1A outputs.
- 2) 1A Output (Case pins 6 and 7 connected together). Output current per graph.
- 3) 2A Output (Case pins 6,7 and 8 connected together). Output current two times values of graph.

CURRENT (Amps) per Output

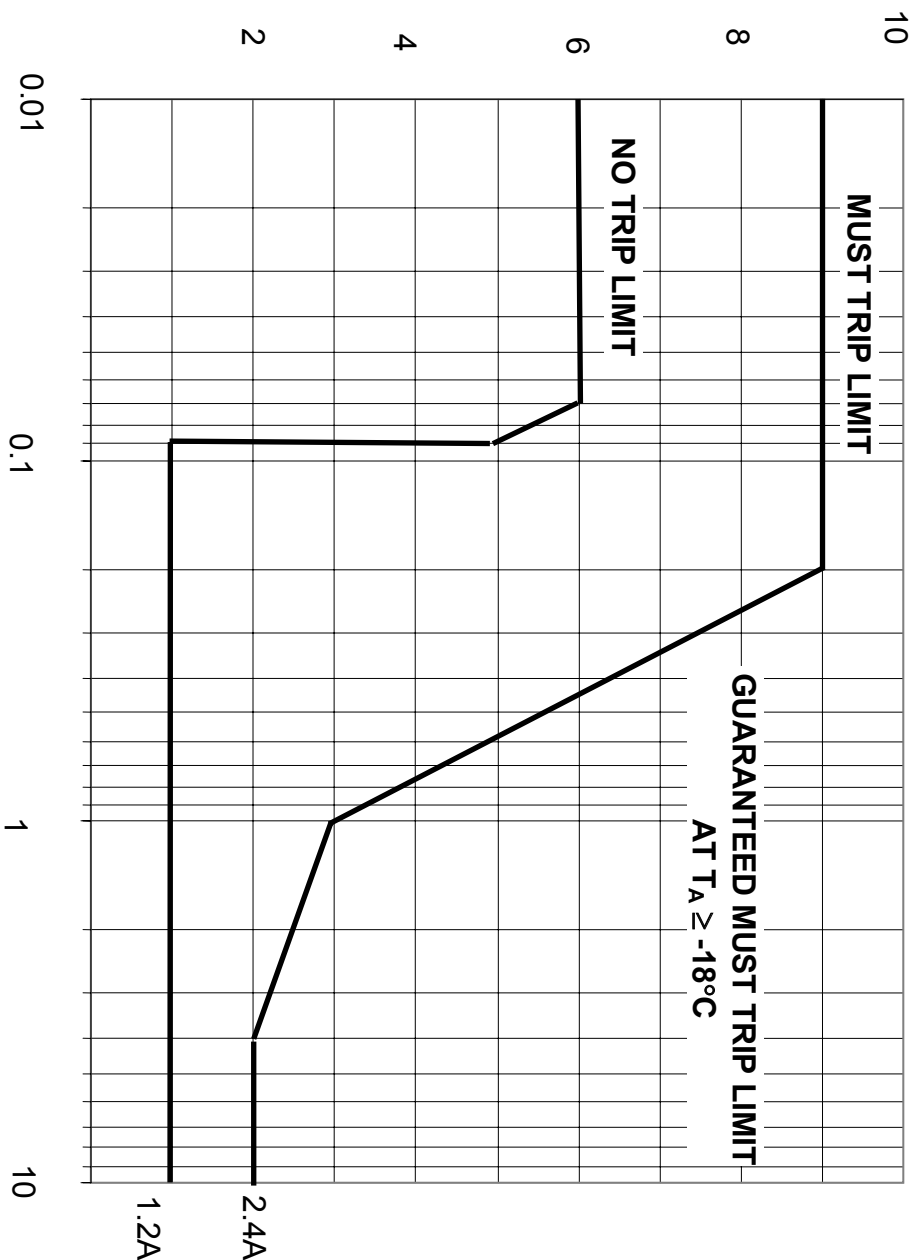

Micropac Industries cannot assume any responsibility for any circuits shown or represent that they are free from patent infringement. Micropac reserves the right to make changes at any time in order to improve design and to supply the best product possible.