

A 1.55V to 5.25V, 1.9µA, 3.3µs to 233s Silicon Timer

FEATURES

- ◆ Ultra Low Supply Current: 1.9µA at 25kHz
- ◆ Supply Voltage Operation: 1.55V to 5.25V
- ◆ Single Resistor Sets FOUT at 50% Duty Cycle
- ◆ 3-pin User-Programmable FOUT Period:
 - $3.3\mu\text{s} \leq t_{\text{FOUT}} \leq 233\text{s}$
- ◆ FOUT Period Accuracy: 3%
- ◆ FOUT Period Drift: 0.02%/°C
- ◆ Single Resistor Sets Output Frequency
- ◆ Separate PWM Control and Buffered Output
- ◆ FOUT/PWMOUT Output Driver Resistance: 160Ω

DESCRIPTION

The TS3004 is a single-supply, second-generation Touchstone Semi oscillator/timer fully specified to operate at a supply voltage range of 1.55V to 5.25V while consuming less than 2.4µA(max) supply current. Requiring only a resistor to set the base output frequency (or output period) at 25kHz (or 40µs) with a 50% duty cycle, the TS3004 timer/oscillator is compact, easy-to-use, and versatile. Optimized for ultra-long life, low frequency, battery-powered/portable applications, the TS3004 joins the TS3001, TS3002, TS3003 and TS3006 in Touchstone's CMOS timer family in its "NanoWatt Analog™" series of high-performance analog integrated circuits.

The TS3004 output period can be user-adjusted from 3.3µs to 233s without additional components. In addition, the TS3004 represents a 25% reduction in pcb area and a factor-of-10 lower power consumption over other CMOS-based integrated circuit oscillators/timers. When compared against industry-standard 555-timer-based products, the TS3004 offers up to 84% reduction in pcb area and over three orders of magnitude lower power consumption.

The TS3004 is fully specified over the -40°C to +85°C temperature range and is available in a low-profile, 10-pin 3x3mm TDFN package with an exposed back-side paddle.

APPLICATIONS

- Portable and Battery-Powered Equipment
- Low-Parts-Count Nanopower Oscillator
- Compact Micropower Replacement for Crystal and Ceramic Oscillators
- Micropower Pulse-width Modulation Control
- Micropower Pulse-position Modulation Control
- Micropower Clock Generation
- Micropower Sequential Timing

TYPICAL APPLICATION CIRCUIT

TS3004 Flashing Railroad Lights Circuit

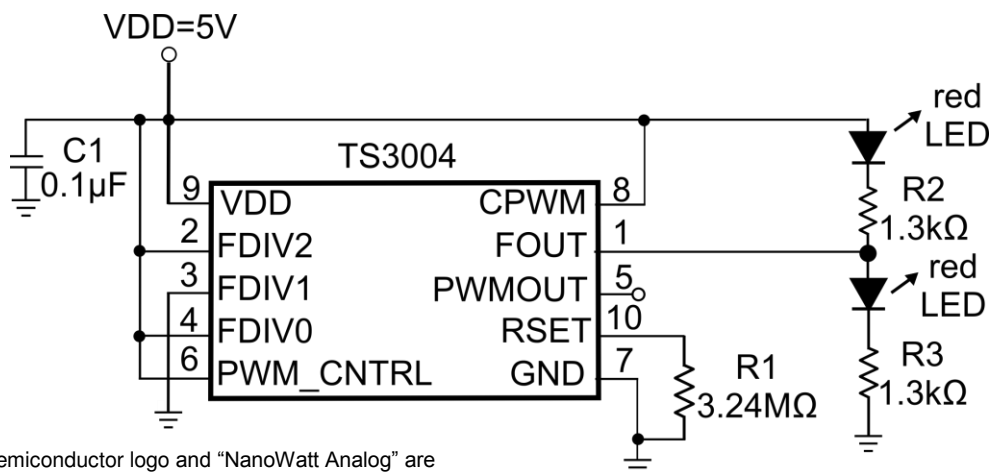

The Touchstone Semiconductor logo and "NanoWatt Analog" are registered trademarks of Touchstone Semiconductor, Incorporated.

ABSOLUTE MAXIMUM RATINGS

| | |
|-----------------------------|----------------|
| V _{DD} to GND..... | -0.3V to +5.5V |
| PWM_CNTRL to GND | -0.3V to +5.5V |
| FOUT, PWMOUT to GND..... | -0.3V to +5.5V |
| RSET to GND..... | -0.3V to +2.5V |
| CPWM to GND | -0.3V to +5.5V |
| FDIV to GND | -0.3V to +5.5V |

| | |
|---|-----------------|
| Continuous Power Dissipation (T _A = +70°C) | |
| 10-Pin TDFN (Derate at 13.48mW/°C above +70°C) ... | 1078mW |
| Operating Temperature Range..... | -40°C to +85°C |
| Storage Temperature Range..... | -65°C to +150°C |
| Lead Temperature (Soldering, 10s)..... | +300°C |

Electrical and thermal stresses beyond those listed under “Absolute Maximum Ratings” may cause permanent damage to the device. These are stress ratings only and functional operation of the device at these or any other condition beyond those indicated in the operational sections of the specifications is not implied. Exposure to any absolute maximum rating conditions for extended periods may affect device reliability and lifetime.

PACKAGE/ORDERING INFORMATION

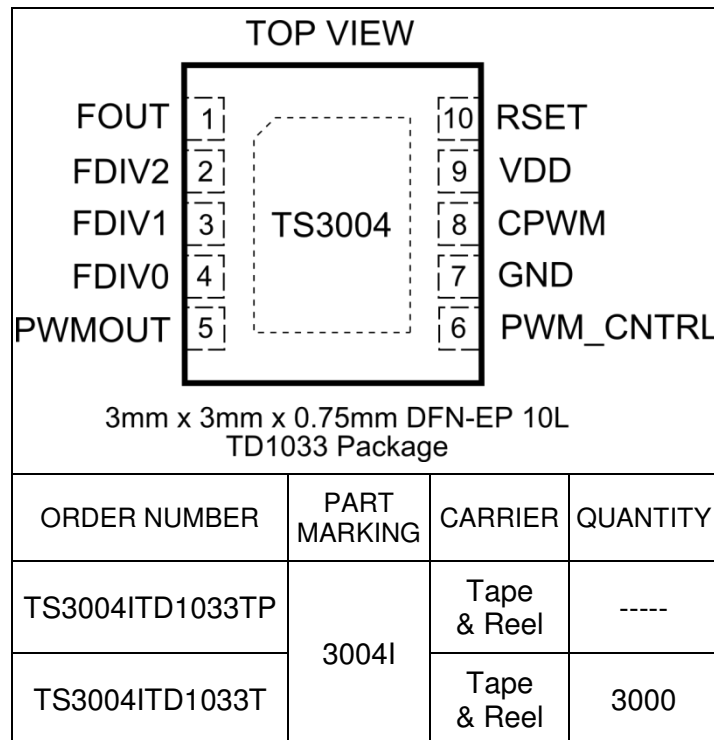

Lead-free Program: Touchstone Semiconductor supplies only lead-free packaging.

Consult Touchstone Semiconductor for products specified with wider operating temperature ranges.

ELECTRICAL CHARACTERISTICS

$V_{DD} = 3V$, $V_{PWM_CNTRL} = V_{DD}$, $R_{SET} = 4.32M\Omega$, $R_{LOAD(FOUT)} = \text{Open Circuit}$, $C_{LOAD(FOUT)} = 0pF$, $C_{LOAD(PWM)} = 0pF$, $C_{PWM} = 47pF$, $FDIV2:0 = 000$ unless otherwise noted. Values are at $T_A = 25^\circ C$ unless otherwise noted. See Note 1.

| PARAMETER | SYMBOL | CONDITIONS | MIN | TYP | MAX | UNITS |
|--|----------------------------|---|------|-------|------|---------|
| Supply Voltage | V_{DD} | | 1.55 | | 5.25 | V |
| Supply Current | I_{DD} | $CPWM = V_{DD}$ | | 1.9 | 2.4 | μA |
| | | $-40^\circ C \leq T_A \leq 85^\circ C$ | | | 2.7 | |
| | | | | 3.3 | 3.6 | |
| FOUT Period | t_{FOUT} | | 39 | 40.1 | 41.2 | μs |
| | | $-40^\circ C \leq T_A \leq 85^\circ C$ | 38 | | 42 | |
| FOUT Period Line Regulation | $\Delta t_{FOUT}/V$ | $1.55V \leq V_{DD} \leq 5.25V$ | | 0.17 | | %/V |
| FOUT Duty cycle | | | 49 | | 51 | % |
| FOUT Period Temperature Coefficient | $\Delta t_{FOUT}/\Delta T$ | | | 0.02 | | %/°C |
| PWMOUT Duty Cycle | DC(PWMOUT) | | 37 | 41.6 | 48 | % |
| | | $V_{PWM_CNTRL} = 0V$ | 15 | | 24 | |
| PWMOUT Duty Cycle Line Regulation | $\Delta DC(PWMOUT)/V$ | $1.55V < V_{DD} < 5.25V$, $FDIV2:0 = 000$ | | -3 | | % |
| C_{PWM} Sourcing Current | I_{CPWM} | $FDIV2:0 = 000, 001$ | 930 | | 1050 | nA |
| | | $-40^\circ C \leq T_A \leq 85^\circ C$ | 810 | | 1150 | |
| | | $FDIV2:0 \neq 000, 001$ | | 97 | | nA |
| UVLO Hysteresis | V_{UVLO} | $(V_{DD}=1.55V) - (V_{DD_SHUTDOWN VOLTAGE})$ | 150 | | 250 | mV |
| FOUT, PWMOUT Rise Time | t_{RISE} | See Note 2, $C_L = 15pF$ | | 10 | | ns |
| FOUT, PWMOUT Fall Time | t_{FALL} | See Note 2, $C_L = 15pF$ | | 10 | | ns |
| FOUT Jitter | | See Note 3 | | 0.001 | | % |
| RSET Pin Voltage | $V(RSET)$ | | | 0.3 | | V |
| FDIV Input Current | I_{FDIV} | | | | 10 | nA |
| | | $-40^\circ C \leq T_A \leq 85^\circ C$ | | | 20 | |
| Maximum Oscillator Frequency | F_{osc} | $RSET = 360K$ | | | 300 | kHz |
| High Level Output Voltage, FOUT and PWMOUT | $V_{DD} - V_{OH}$ | $I_{OH} = 1mA$ | | 160 | | mV |
| Low Level Output Voltage, FOUT and PWMOUT | V_{OL} | $I_{OL} = 1mA$ | | 140 | | mV |
| Dead Time | T_{DT} | FOUT edge falling and PWMOUT edge rising | | 106 | | ns |

Note 1: All devices are 100% production tested at $T_A = +25^\circ C$ and are guaranteed by characterization for $T_A = T_{MIN}$ to T_{MAX} , as specified.

Note 2: Output rise and fall times are measured between the 10% and 90% of the V_{DD} power-supply voltage levels. The specification is based on lab bench characterization and is not tested in production.

Note 3: Timing jitter is the ratio of the peak-to-peak variation of the period to the mean of the period. The specification is based on lab bench characterization and is not tested in production.

TYPICAL PERFORMANCE CHARACTERISTICS

$V_{DD} = 3V$, $V_{PWM_CNTRL} = V_{DD}$, $R_{SET} = 4.32M\Omega$, $R_{LOAD(FOUT)} = \text{Open Circuit}$, $C_{LOAD(FOUT)} = 0pF$, $C_{LOAD(PWM)} = 0pF$, $CPWM = V_{DD}$, $FDIV2:0 = 000$ unless otherwise noted. Values are at $T_A = 25^\circ C$ unless otherwise noted.

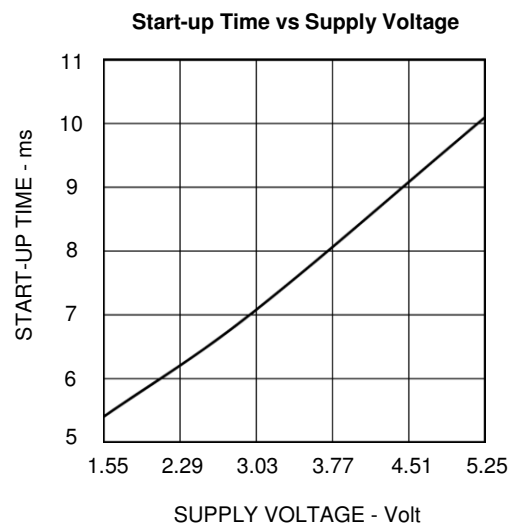
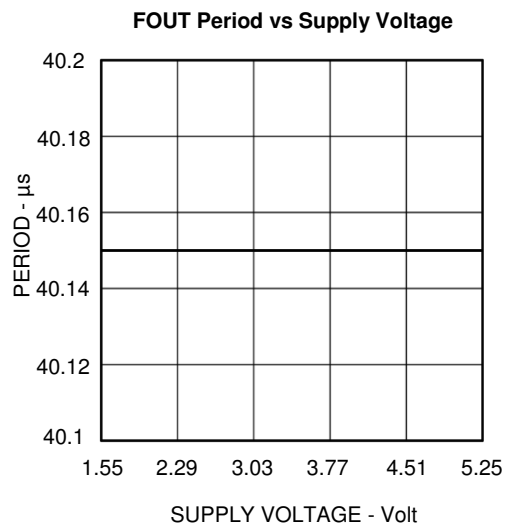
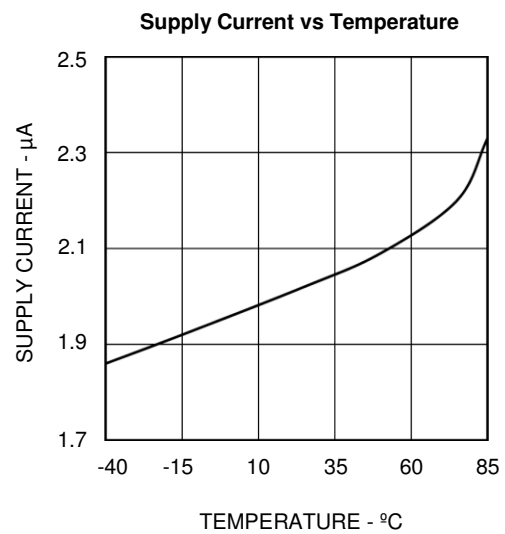
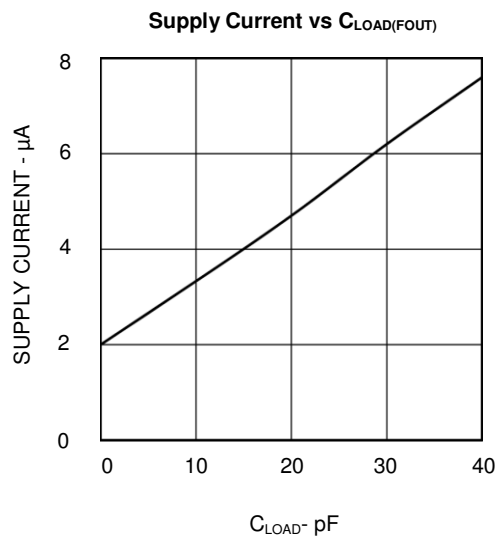
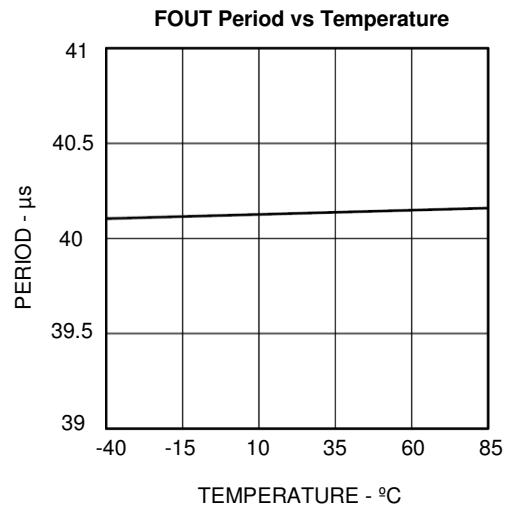
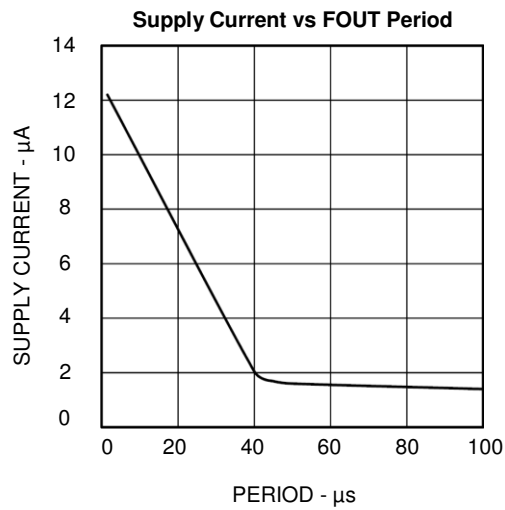

TYPICAL PERFORMANCE CHARACTERISTICS

$V_{DD} = 3V$, $V_{PWM_CNTRL} = V_{DD}$, $R_{SET} = 4.32M\Omega$, $R_{LOAD(FOUT)} = \text{Open Circuit}$, $C_{LOAD(FOUT)} = 0pF$, $C_{LOAD(PWM)} = 0pF$, $CPWM = V_{DD}$, $FDIV2:0 = 000$ unless otherwise noted. Values are at $T_A = 25^\circ C$ unless otherwise noted.

Period vs R_{SET}

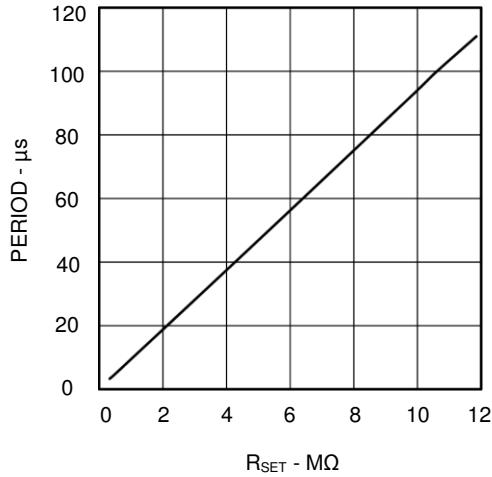

Supply Current Distribution

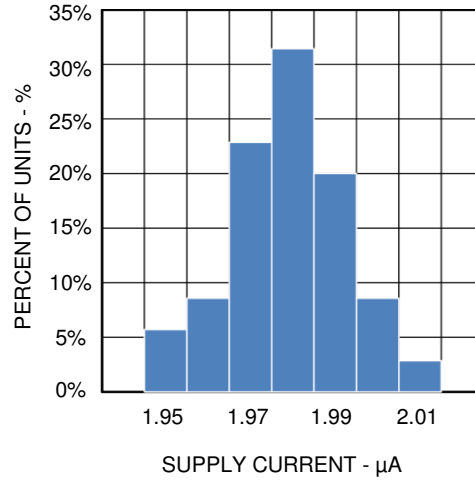

FOUT
 $V_{DD} = 3V$, $C_{LOAD} = 15pF$

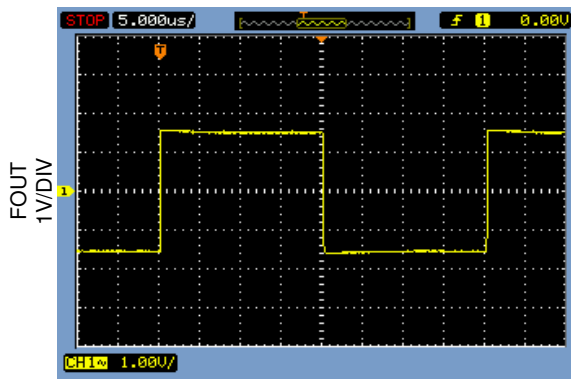

5μs/DIV

FOUT
 $V_{DD} = 5V$, $C_{LOAD} = 15pF$

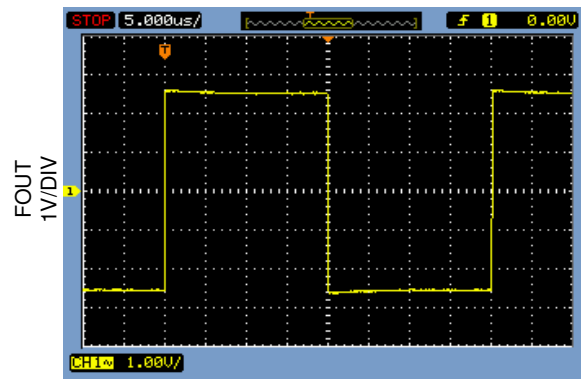

5μs/DIV

FOUT and PWMOUT
 $V_{DD} = 3V$, $C_{LOAD} = 15pF$, $V_{PWM_CNTRL} = V_{DD}$, $CPWM = 47pF$

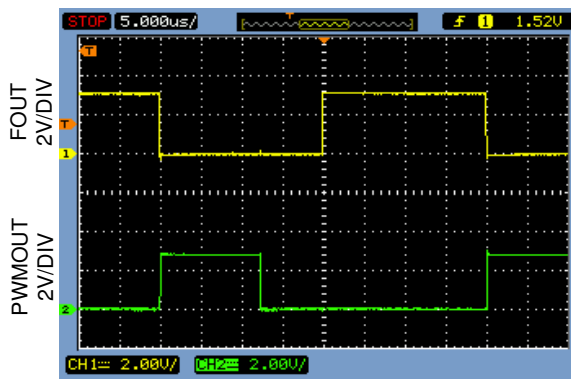

5μs/DIV

FOUT and PWMOUT
 $V_{DD} = 5V$, $C_{LOAD} = 15pF$, $V_{PWM_CNTRL} = V_{DD}$, $CPWM = 47pF$

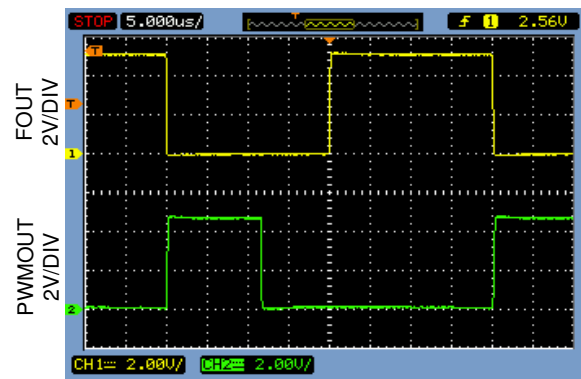

5μs/DIV

PIN FUNCTIONS

| PIN | NAME | FUNCTION |
|-------|-----------|---|
| 1 | FOUT | Fixed Frequency Output. A push-pull output stage with an output resistance of 160Ω. FOUT pin swings from GND to VDD. For lowest power operation, capacitance loads should be minimized and resistive loads should be maximized. |
| 2,3,4 | FDIV2:0 | Frequency Divider Input. Various combinations of these inputs will change the FOUT frequency for a fixed value of RSET. Refer to Table 1. |
| 5 | PWMOUT | Pulse-width Modulated Output. A push-pull output stage with an output resistance of 160Ω, the PWMOUT pin is wired anti-phase with respect to FOUT and swings from GND to VDD. For lowest power operation, capacitance loads should be minimized and resistive loads should be maximized. |
| 6 | PWM_CNTRL | PWM Output Pulse Control Pin. Applying a voltage between GND and V_{RSET} will reduce the duty cycle of the PWMOUT output that is set by the capacitor connected to the CPWM pin. Connect PWM_CNTRL to VDD for fixed PWMOUT output pulse time (determined only by capacitor at CPWM). |
| 7 | GND | Ground. Connect this pin to the system's analog ground plane. |
| 8 | CPWM | PWMOUT Pulse Width Programming Capacitance Input. A target capacitance connected from this pin to GND sets the duty cycle of the PMW output. Minimize any stray capacitance on this pin. The voltage on this pin will swing from GND to V_{RSET} . Connect CPWM to VDD to disable PWM function (saves PWM current). |
| 9 | VDD | Power Supply Voltage Input. The supply voltage range is $1.55V \leq V_{DD} \leq 5.25V$. Bypass this pin with a 0.1uF ceramic coupling capacitor in close proximity to the TS3004. |
| 10 | RSET | FOUT Programming Resistor Input. A 4.32MΩ resistor connected from this pin to ground sets the T3004's internal oscillator's output period to 40μs (25KHz). For optimal performance, the composition of the RSET resistor shall be consistent with a tolerance of 1% or lower. The RSET pin voltage is approximately 0.3V. |

BLOCK DIAGRAM

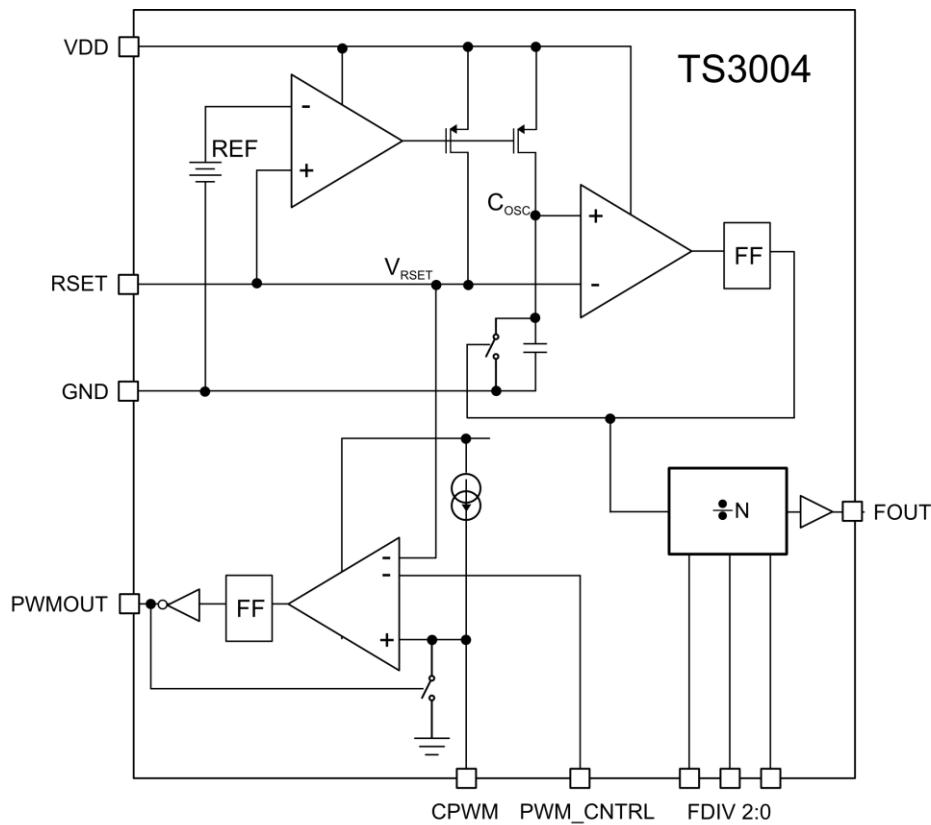

| FDIV 2:0 | t _{FOUT} (s) | FOUT (Hz) | I _{CPWM} (A) |
|----------|-----------------------|---------------|-----------------------|
| 000 | 3.3μ-111.1μs | 300k-9k | 1μ |
| 001 | 26.4μ-888.88μs | 37.5k-1.125k | 1μ |
| 010 | 211.2μ-7.11ms | 4.69k-140.62 | 100n |
| 011 | 1.7ms-56.88ms | 586-17.578 | 100n |
| 100 | 13.6ms-455.16ms | 73.25-2.197 | 100n |
| 101 | 108.8ms-3.64 | 9.16-0.2746 | 100n |
| 110 | 870.4ms-29.15 | 1.14-0.0343 | 100n |
| 111 | 6.99-233 | 0.143-0.00429 | 100n |

Table 1: FOUT and PWMOUT Frequency Range per FDIV2:0 Combination

THEORY OF OPERATION

The TS3004 is a user-programmable oscillator where the period of the square wave at its FOUT terminal is generated by an external resistor connected to the RSET pin. The output period is given by:

$$t_{FOUT} (s) = \frac{8^{FDIV2:0} \times RSET}{1.08E11}$$

Equation 1. FOUT Frequency Calculation where FDIV2:0 = 0 to 7

| R _{SET} (MΩ) | t _{FOUT} (s) |
|-----------------------|-----------------------|
| 0.360 | 6.99 |
| 1 | 19.42 |
| 2.49 | 48.35 |
| 4.32 | 83.89 |
| 6.81 | 132.27 |
| 9.76 | 189.39 |
| 12 | 233 |

Table 2: t_{FOUT} vs R_{SET} for FDIV2:0 = 111(7)

With an $R_{SET} = 4.32M\Omega$ and $FDIV2:0=111$, the FOUT period is approximately 83.89s with a 50% duty cycle. As design aids, Tables 2 lists TS3004’s typical FOUT period for various standard values for R_{SET} and $FDIV2:0 = 111(7)$.

The output period can be user-adjusted from 3.3 μ s to 233s without additional components. Frequency divider inputs $FDIV2:0$ can be set to a logic state HIGH or LOW in order to set the desired frequency as shown in to Table 1.

The TS3004 also provides a separate PWM output signal at its PWMOUT terminal that is anti-phase with respect to FOUT. A dead time of approximately 106ns exists between FOUT and PWMOUT. To adjust the pulse width of the PWMOUT output, a single capacitor can be placed at the CPWM pin. To determine the capacitance needed for a desired pulse width, the following equation is to be used:

$$CPWM(F) = \frac{\text{Pulse Width(s)} \times I_{CPWM}}{V_{CPWM} \cong 300mV}$$

Equation 2. CPWM Capacitor Calculation

where I_{CPWM} and V_{CPWM} is the current supplied and voltage applied to the CPWM capacitor, respectively. The pulse width is determined based on the period of FOUT and should never be greater than the period at FOUT. Make sure the PWM_CNTRL pin is set to at least 400mV when calculating the pulse width of PWMOUT. Note V_{CPWM} is approximately 300mV, which is the RSET voltage. Also note that I_{CPWM} is either 1 μ A or 100nA. Refer to Table 1.

The PWMOUT output pulse width can be adjusted further after selecting a CPWM capacitor. This can be achieved by applying a voltage to the PWM_CNTRL pin between V_{RSET} and GND. With a voltage of at least V_{RSET} , the pulse width is set based on Equation 2. For example, with a period of 40 μ s(25kHz) a 47pF capacitor at the CPWM pin generates a pulse width of approximately 16 μ s. This can be calculated using equation 2. By reducing the PWM_CNTRL voltage from $V_{RSET} \cong 300mV$ to GND, the pulse width is reduced from 16 μ s to approximately 8 μ s. This is a pulse width reduction of 50%. Note that as the FOUT frequency increases, the amount of pulse width reduction reduces and vice versa. Furthermore, if the PWMOUT output is half the frequency of the FOUT output, this means your CPWM capacitor is too large and as a result, the pulse width is greater than the FOUT period. In this case, use Equation 2 and reduce the capacitor value to less than the period.

Connect CPWM to VDD to disable the PWM function and in turn, save power. Connect PWM_CNTRL to VDD for a fixed PWMOUT output pulse width, which is determined by the CPWM pin capacitor only.

APPLICATIONS INFORMATION

Minimizing Power Consumption

To keep the TS3004’s power consumption low, resistive loads at the FOUT and PWMOUT terminals increase dc power consumption and therefore should be as large as possible. Capacitive loads at the FOUT and PWMOUT terminals increase the TS3004’s transient power consumption and, as well, should be as small as possible.

One challenge to minimizing the TS3004’s transient power consumption is the probe capacitance of oscilloscopes and frequency counter instruments. Most instruments exhibit an input capacitance of 15pF or more. Unless buffered, the increase in transient load current can be as much as 400nA.

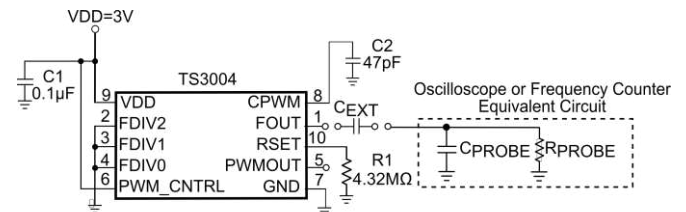

Figure 1: Using an External Capacitor in Series with Probes Reduces Effective Capacitive Load.

To minimize capacitive loading, the technique shown in Figure 1 can be used. In this circuit, the principle of series-connected capacitors can be used to reduce the effective capacitive load at the TS3004’s FOUT and PWMOUT terminals.

To determine the optimal value for C_{EXT} once the probe capacitance is known by simply solving for C_{EXT} using the following expression:

$$C_{EXT} = \frac{1}{\frac{1}{C_{LOAD(EFF)}} - \frac{1}{C_{PROBE}}}$$

Equation 3:External Capacitor Calculation

approximately 80 μ s. This is well above the required minimum pulse width of 40 μ s.

Flashing Railroad Lights with the TS3004

With only three resistors and two off the shelf LEDs, the TS3004 can be configured into a flashing railroad lights circuit. With the input divider set to FDIV2:0 = 101 and RSET= 3.24M Ω , the FOUT output frequency is 1Hz. Refer to Figure 4. During the time the output is HIGH, only the pull-down LED is on while when the output is LOW, only the pull-up LED is on. The supply voltage of the circuit is 5V.

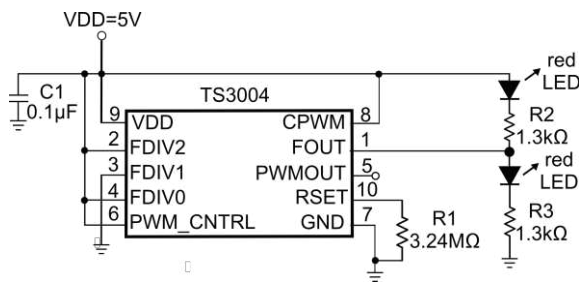

Figure 4: Flashing Railroad Lights with the TS3004

Using the TS3004 and a Potentiometer to Dim an LED

The TS3004 can be configured to dim an LED by modulating the pulse width of the PWMOUT output. With the input divider set to FDIV2:0 = 011 and RSET= 2M Ω , the FOUT output frequency is approximately 100Hz (or 10ms period). Refer to Figure 5. The CPWM capacitor was calculated using Equation 2 with a pulse width of 8.1ms. To reduce the pulse width from 8.1ms and in turn, dim the LED, a 1M Ω potentiometer is used. The potentiometer is connected to the PWM_CNTRL pin in a voltage divider configuration. The supply voltage of the circuit is 5V.

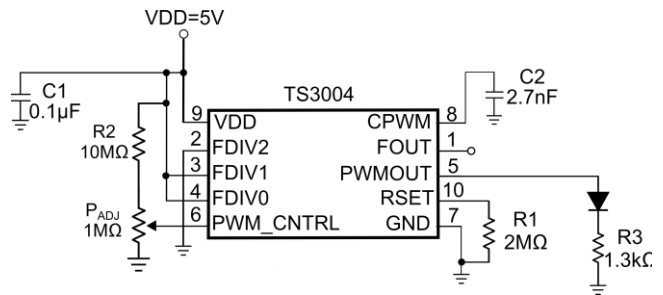
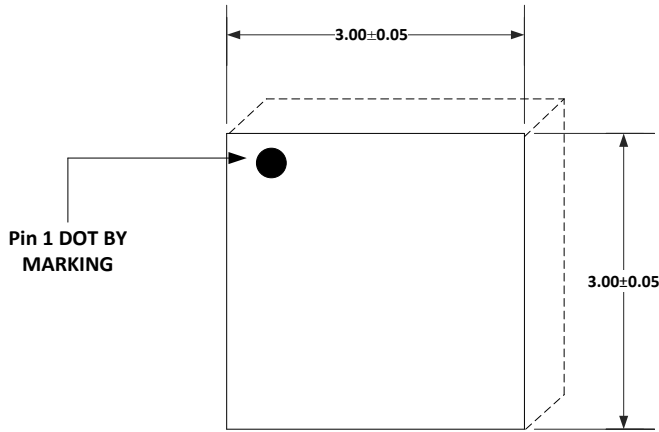

Figure 5: TS3004 Configured to Dim an LED with a Potentiometer

PACKAGE OUTLINE DRAWING

10-Pin TDFN33 Package Outline Drawing

(N.B., Drawings are not to scale)



TOP VIEW

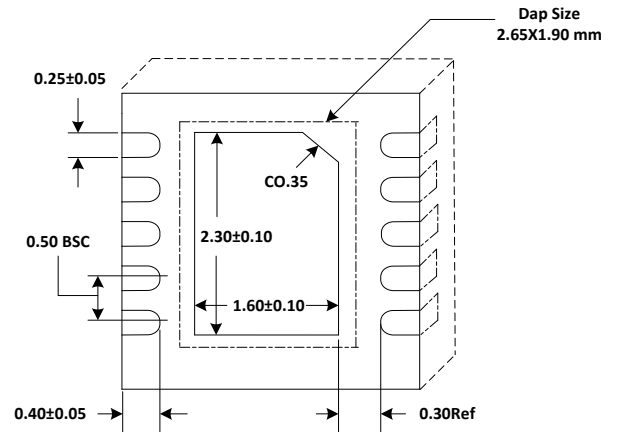

BOTTOM VIEW

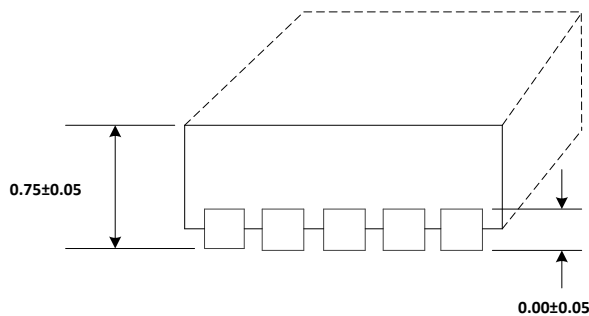

SIDE VIEW

NOTE!

- All dimensions in mm.
- Compliant with JEDEC MO-229

Information furnished by Touchstone Semiconductor is believed to be accurate and reliable. However, Touchstone Semiconductor does not assume any responsibility for its use nor for any infringements of patents or other rights of third parties that may result from its use, and all information provided by Touchstone Semiconductor and its suppliers is provided on an AS IS basis, WITHOUT WARRANTY OF ANY KIND. Touchstone Semiconductor reserves the right to change product specifications and product descriptions at any time without any advance notice. No license is granted by implication or otherwise under any patent or patent rights of Touchstone Semiconductor. Touchstone Semiconductor assumes no liability for applications assistance or customer product design. Customers are responsible for their products and applications using Touchstone Semiconductor components. To minimize the risk associated with customer products and applications, customers should provide adequate design and operating safeguards. Trademarks and registered trademarks are the property of their respective owners.