

PROTO-SHIELD development board

Users Manual



All boards produced by Olimex are ROHS compliant

Revision Initial, June 2011

Copyright(c) 2011, OLIMEX Ltd, All rights reserved

INTRODUCTION:

PROTO-SHIELD is prototype board compatible with all of Olimex's ARDUINO compatible boards – like OLIMEXINO-328, OLIMEXINO-STM32 and PIC32-PINGUINO. The board comes without mounted connectors on it, but it is shipped with one 6x1 connector and three 8x1 connectors, which can be mounted by the customer. The prototype area gives user the opportunity to solder different extensions for ARDUINO compatible boards. All this allows you to build a diversity of applications.

BOARD FEATURES:

- one 6x1 connector – not mounted
- three 8x1 connectors – not mounted
- two status leds
- two user buttons
- prototype area
- FR-4, 1.5 mm, soldermask, component print
- Dimensions: 68.58 x 53.34mm (2.71 x 2.11")

ELECTROSTATIC WARNING:

The **PROTO-SHIELD** board is shipped in protective anti-static packaging. The board must not be subject to high electrostatic potentials. General practice for working with static sensitive devices should be applied when working with this board.

BOARD USE REQUIREMENTS:

Hardware: The board can be used with any of our ARDUINO compatible boards: [OLIMEXINO-328](#), [OLIMEXINO-STM32](#), [PIC32-PINGUINO](#), [PIC32-PINGUINO-OTG](#).

SCHEMATIC:

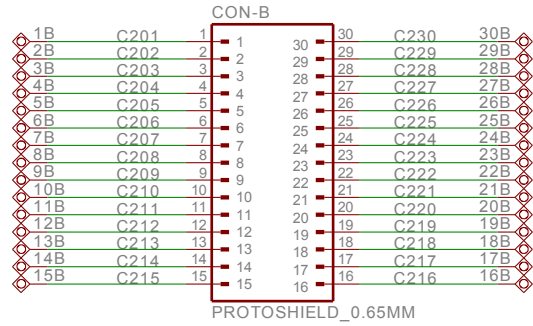
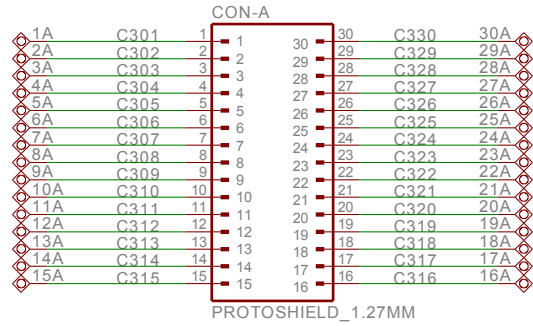
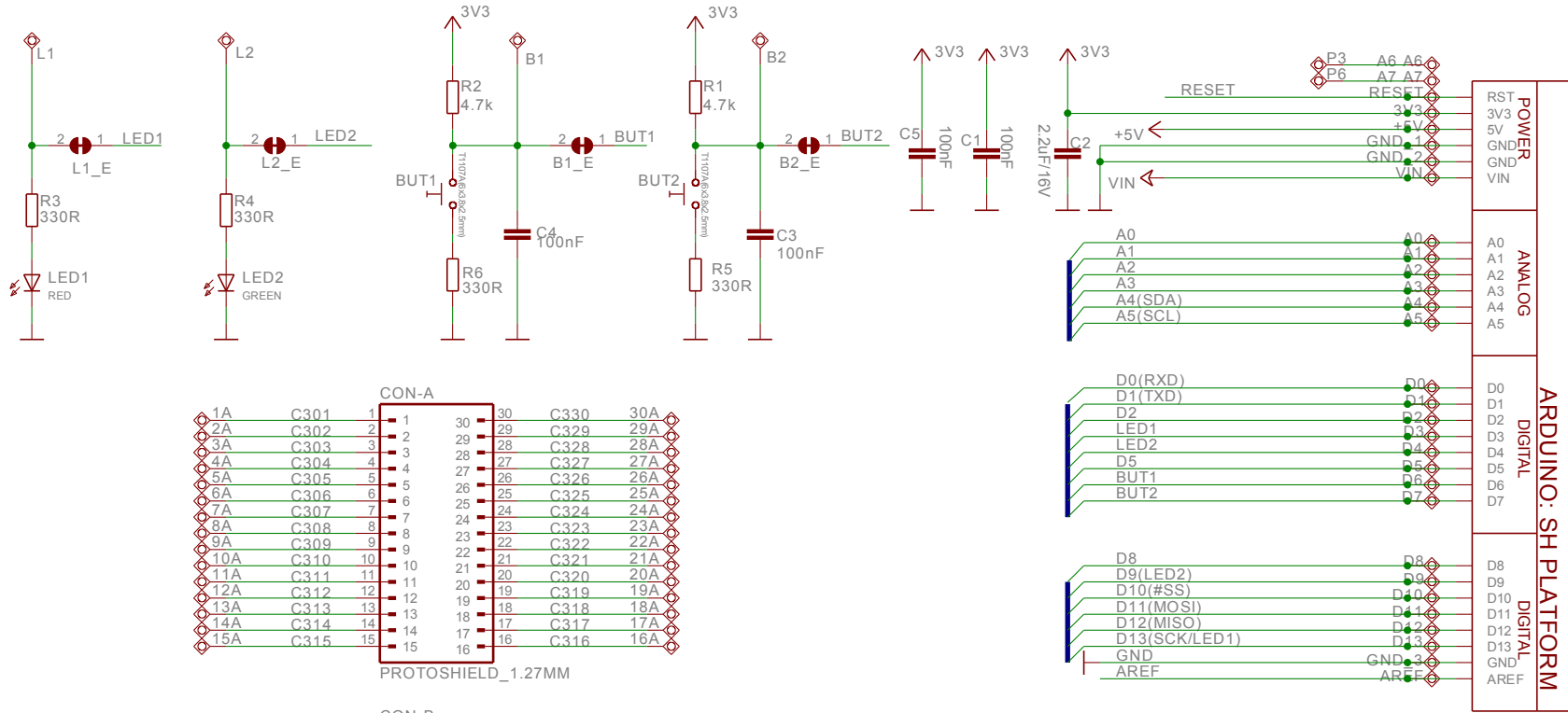

PROTO-SHIELD

Rev.A

COPYRIGHT(C) 2011, OLIMEX Ltd.

<http://www.olimex.com/dev>

BOARD LAYOUT:

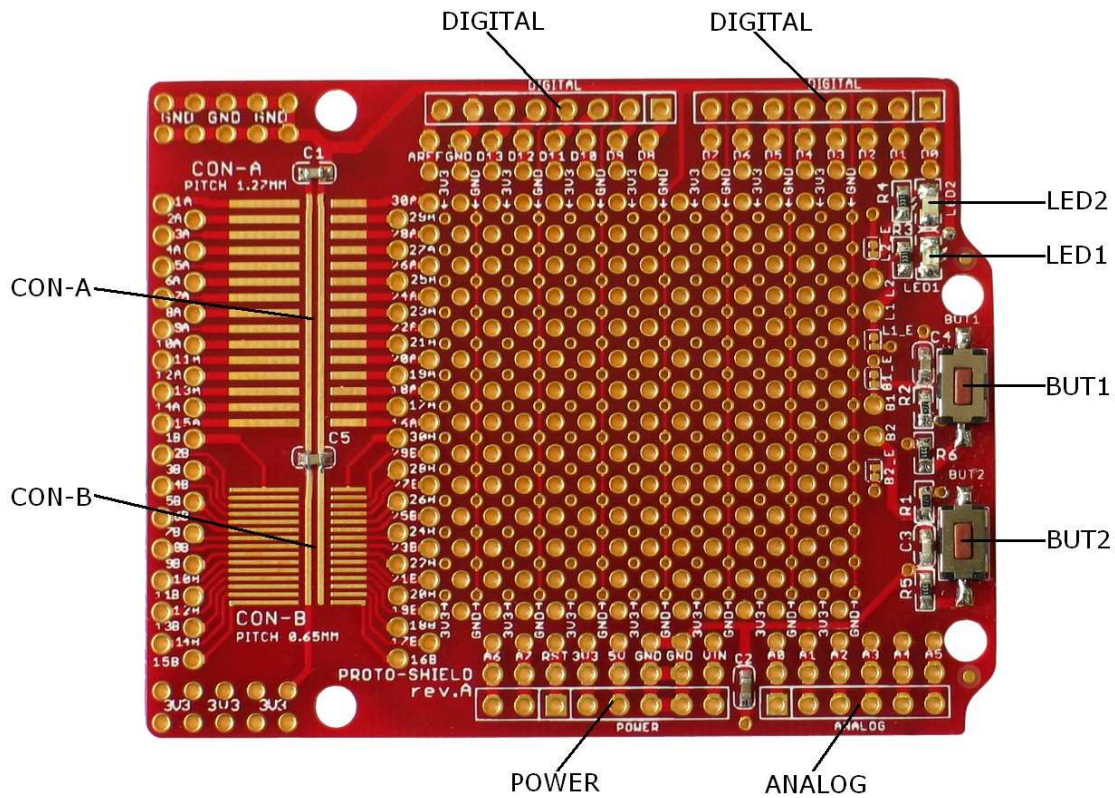

POWER SUPPLY CIRCUIT:

PROTO-SHIELD is power supplied via POWER connector from the ARDUINO compatible board with which is used.

JUMPER DESCRIPTION:

L1_E



This jumper, when closed, LED1 is connected to D3 line.
This jumper, when opened, LED1 is connected to L1 pad.
Default state is closed.

L2_E



This jumper, when closed, LED2 is connected to D4 line.
This jumper, when opened, LED2 is connected to L2 pad.
Default state is closed.

B1_E



This jumper, when closed, BUT1 is connected to D6 line.
This jumper, when opened, BUT1 is connected to B1 pad.
Default state is closed.

B2_E



This jumper, when closed, BUT2 is connected to D7 line.
This jumper, when opened, BUT2 is connected to B2 pad
Default state is closed.

INPUT/OUTPUT:

Status Led with name **LED1 (red)** connected via jumper L1_E to DIGITAL connector pin D3 – signal LED1.

Status Led with name **LED2 (green)** connected via jumper L2_E to DIGITAL connector pin D4 – signal LED2.

User button with name **BUT1** connected via jumper B1_E to DIGITAL connector pin D6 – signal BUT1.

User button with name **BUT2** connected via jumper B2_E to DIGITAL connector pin D7 – signal BUT2.

EXTERNAL CONNECTORS DESCRIPTION:

POWER:

Pin #	Signal Name
1	A6
2	A7
3	RESET
4	VCC
5	+5V
6	GND
7	GND
8	+24V (VIN)



Note: This connector is not mounted on the board.

ANALOG:

Pin #	Signal Name
1	A0
2	A1
3	A2
4	A3
5	A4(SDA)
6	A5(SCL)

Note: This connector is not mounted on the board.

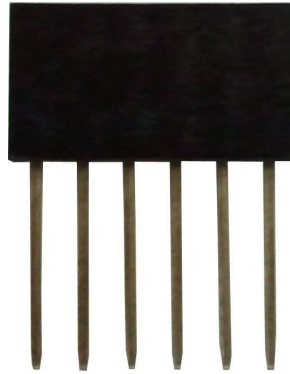

DIGITAL:

Pin #	Signal Name
1	D0(RXD)
2	D1(TXD)
3	D2
4	LED1
5	LED2
6	D5
7	BUT1
8	BUT2

Note: This connector is not mounted on the board.

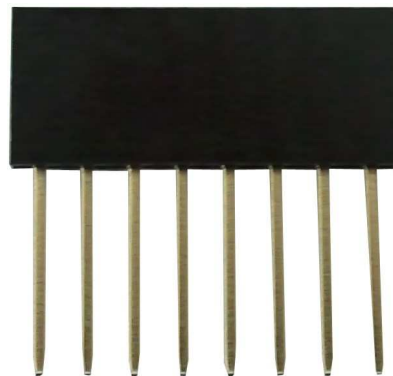

DIGITAL:

Pin #	Signal Name
1	D8
2	D9(LED2)
3	D10(#SS)
4	D11(MOSI)
5	D12(MISO)
6	D13(SCK/LED1)
7	GND
8	AREF

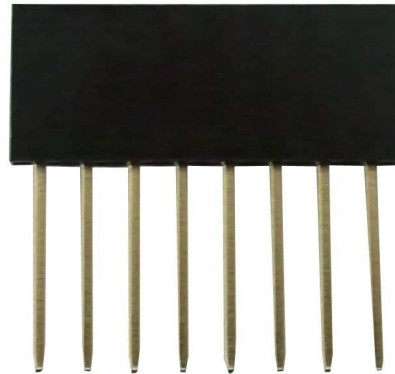

Note: This connector is not mounted on the board.

CON-A:

Note: This footprint can be used for mounting of SMD IC with 1.27mm pitch. Each of SMD pads is routed to True Hole pad.

SMD Pin #	True Hole pin #	SMD Pin #	True Hole pin #
1	1A	2	2A
3	3A	4	4A
5	5A	6	6A
7	7A	8	8A
9	9A	10	10A
11	11A	12	12A
13	13A	14	14A
15	15A	16	16A
17	17A	18	18A
19	19A	20	20A
21	21A	22	22A
23	23A	24	24A
25	25A	26	26A
27	27A	28	28A
29	29A	30	30A

CON-A **PITCH 1.27MM**

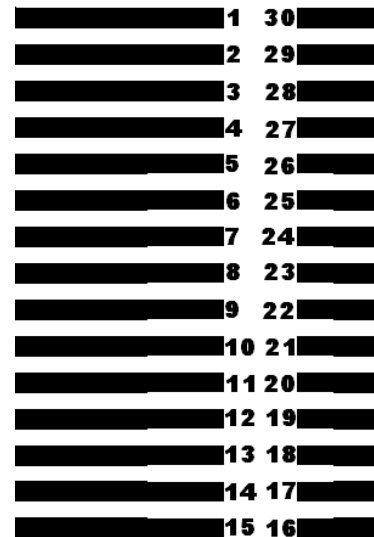

CON-B:

Note: This footprint can be used for mounting of SMD IC with 0.65mm pitch. Each of SMD pads is routed to True Hole pad.

SMD Pin #	True Hole pin #	SMD Pin #	True Hole pin #
1	1B	2	2B
3	3B	4	4B
5	5B	6	6B
7	7B	8	8B
9	9B	10	10B
11	11B	12	12B
13	13B	14	14B
15	15B	16	16B
17	17B	18	18B
19	19B	20	20B
21	21B	22	22B
23	23B	24	24B
25	25B	26	26B
27	27B	28	28B
29	29B	30	30B

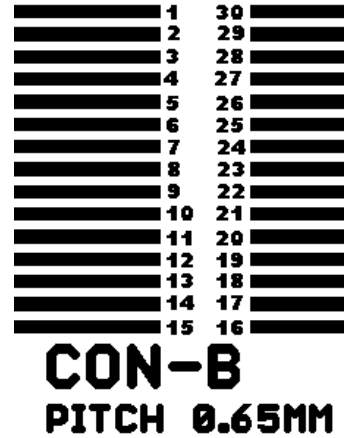

ORDER CODE:

PROTO-SHIELD - assembled and tested board

How to order?

You can order to us directly or by any of our distributors.
Check our web www.olimex.com/dev for more info.

Revision history:

Board's revision	Rev. A, May 2011
Manual's revision	Rev. Initial, June 2011

Disclaimer:

© 2011 Olimex Ltd. All rights reserved. Olimex®, logo and combinations thereof, are registered trademarks of Olimex Ltd. Other terms and product names may be trademarks of others.

The information in this document is provided in connection with Olimex products. No license, express or implied or otherwise, to any intellectual property right is granted by this document or in connection with the sale of Olimex products.

Neither the whole nor any part of the information contained in or the product described in this document may be adapted or reproduced in any material from except with the prior written permission of the copyright holder.

The product described in this document is subject to continuous development and improvements. All particulars of the product and its use contained in this document are given by OLIMEX in good faith. However all warranties implied or expressed including but not limited to implied warranties of merchantability or fitness for purpose are excluded.

This document is intended only to assist the reader in the use of the product. OLIMEX Ltd. shall not be liable for any loss or damage arising from the use of any information in this document or any error or omission in such information or any incorrect use of the product.