



SANYO Semiconductors

DATA SHEET

An ON Semiconductor Company

STK760-216-E — Thick-Film Hybrid IC Single-phase rectification Active Converter Hybrid IC

Overview

This IC is average current control type Active Converter Hybrid IC for power factor improvement of single-phase AC power supply, that containing power devices of step-up active converter, control IC over-current and over-voltage protection circuits.

Applications

- Single-phase rectification active filter for power rectification for air conditioners and general-purpose inverters.

Features

- Power switching device for active converter is adopting IGBT.
- Soft start functions and the over current, the over voltage, and the low-voltage are including as protection circuit
- Capable of controlling ON/OFF by logic level input signal.
- Output voltage changeability functions by control signal.

■ Any and all SANYO Semiconductor Co.,Ltd. products described or contained herein are, with regard to "standard application", intended for the use as general electronics equipment. The products mentioned herein shall not be intended for use for any "special application" (medical equipment whose purpose is to sustain life, aerospace instrument, nuclear control device, burning appliances, transportation machine, traffic signal system, safety equipment etc.) that shall require extremely high level of reliability and can directly threaten human lives in case of failure or malfunction of the product or may cause harm to human bodies, nor shall they grant any guarantee thereof. If you should intend to use our products for new introduction or other application different from current conditions on the usage of automotive device, communication device, office equipment, industrial equipment etc. , please consult with us about usage condition (temperature, operation time etc.) prior to the intended use. If there is no consultation or inquiry before the intended use, our customer shall be solely responsible for the use.

■ Specifications of any and all SANYO Semiconductor Co.,Ltd. products described or contained herein stipulate the performance, characteristics, and functions of the described products in the independent state, and are not guarantees of the performance, characteristics, and functions of the described products as mounted in the customer's products or equipment. To verify symptoms and states that cannot be evaluated in an independent device, the customer should always evaluate and test devices mounted in the customer's products or equipment.

STK760-216-E

Specifications

Absolute Maximum Ratings at $T_a = 25^\circ\text{C}$

Parameter		Symbol	Conditions	Ratings	unit
IGBT (TR1+TR2)	Collector-emitter voltage	VCE		600	V
	Repetitive peak collector current	ICP	*1	300	A
	Collector current	IC		148	A
	Power dissipation	PC1		223	W
FRD1 (D1)	Diode reverse voltage	VRM		600	V
	Repetitive peak forward current	IF1P	*1	220	A
	Diode forward current	IF1		73	A
	Power dissipation	PD1		150	W
FRD2 (D2)	Repetitive peak forward current	IF2P	*1	15	A
	Diode forward current	IF2		7	A
	Power dissipation	PD2		13	W
Supply voltage (V_{CC-GND})		V_{CC}		20	V
Signal pin input voltage	Pin 1	VBOP		-0.3 to 9.0	V
	Pin 7	VIS		-10 to 0.3	
	Pin 8	VCOMP		-0.3 to 6.5	
	Pin 12	VFB			
	Pin 13	VOVP			
	Pin 4	VONF		-0.3 to V_{CC}	
	Pin 10	Vctl			
Maximum input AC voltage		VAC	Single-phase Full-rectified	264	V
Maximum output voltage		V_O	Under the Application condition (VAC=200V)	450	V
Maximum output power		W_o		8	kW
Input AC current (normal condition)		I_{IN}		40	Arms
Junction temperature		T_J		150	$^\circ\text{C}$
Operating case temperature		T_c	HIC case temperature *2	-20 to +100	$^\circ\text{C}$
Storage temperature		T_{stg}		-40 to +125	$^\circ\text{C}$
Tightening torque			A screw part *3	1.17	N•m
Withstand voltage		VINS	50Hz sine wave AC 1minute *4	2000	VRMS

[Note]

*1: Duty ratio $D = 0.1$, $t_p = 1\text{ms}$

*2: Measure point is between 5mm to center of back.

*3: Torque should be set within 0.79 to 1.17N•m. Flatness of the heat-sink should be lower than 0.2mm.

*4: The test condition: AC2500V, 1 second.

STK760-216-E

Electrical Characteristics at $T_c = 25^\circ\text{C}$, $V_{CC} = 15.0\text{V}$: Unless otherwise noted

Parameter	Symbol	Conditions	Test circuit	Ratings			unit
				min	typ	max	
Power output part							
Collector-emitter leak current (IGBT)	I_{CES}	$V_{CE} = 600\text{V}$	Fig.1			200	μA
Collector-emitter saturation voltage (IGBT)	$V_{CE(sat)}$	$I_C = 50\text{A}$	Fig.2		1.2	1.8	V
Diode reverse current (FRD1)	I_R	$V_R = 600\text{V}$	Fig.1			200	μA
Diode forward voltage (FRD1)	V_{F1}	$I_F = 50\text{A}$	Fig.3		1.8	2.4	V
Diode forward voltage (FRD2)	V_{F2}	$I_F = 5\text{A}$	Fig.3		2.5	3.5	V
Junction to case thermal resistance	θ_{j-c1}	IGBT (TR1+TR2)			0.56		$^\circ\text{C/W}$
	θ_{j-c2}	FRD1 (D2+D3)			0.83		$^\circ\text{C/W}$
	θ_{j-c3}	FRD2 (D4)			9.0		$^\circ\text{C/W}$
Control IC part							
Control IC input current	$I_{CC(ON)}$	$V_{CC} = 15\text{V}$, $V_{ONF} = 5\text{V}$	Fig.4		14	20	mA
	$I_{CC(OFF)}$	$V_{CC} = 15\text{V}$, $V_{ONF} = 0\text{V}$			2.5	5	
Oscillation frequency	f_{OSC}	$V_{CC} = 15\text{V}$, $V_{ONF} = 5\text{V}$	Fig.4	19.5	22.0	24.5	kHz
Open loop protection threshold voltage	VOLP			0.8	0.95	1.1	V
Error-amp reference voltage	V_{ref}		Fig.5	4.88	5.0	5.12	V
Peak current protection threshold voltage	$V_{IS(PK)}$			-0.58	-0.5	-0.42	V
Over voltage protection threshold voltage	$V_{OVP(ON)}$		Fig.6	5.095	5.3	5.51	V
Brown-out protection threshold voltage	$V_{BOP(ON)}$			0.66	0.76	0.86	V
Brown-out protection enable voltage	$V_{BOP(EN)}$			1.46	1.56	1.66	V
ON/OFF threshold voltage	V_{THON}	$V_{CC} = 15\text{V}$	Fig.7	3.0			V
	V_{THOFF}					0.5	V
Start-up V_{CC} voltage	$V_{CC(ON)}$	$V_{ONF} = 5\text{V}$	Fig.8	12.4	13.25	14.1	V
Shut-down V_{CC} voltage	$V_{CC(OFF)}$			9.4	10.0	10.7	V
Substrate temperature monitor resistance	RTH	Resistance between V_{TH1} - V_{TH2}	Fig.3	90	100	110	$\text{k}\Omega$
Application circuit : $V_{AC} = 200\text{V}$, $V_O = 380\text{V}$ ($V_{ctl} = 1.507\text{V}$)							
Output voltage	V_O	$W_o = 2\text{kW}$	Fig.9	366	380	394	V
Power Factor	$\cos\phi$	$W_o = 400\text{W}$		0.98	0.99		
		$W_o = 2\text{kW}$		0.99	0.995	1.0	

Package Dimensions

unit:mm (typ)

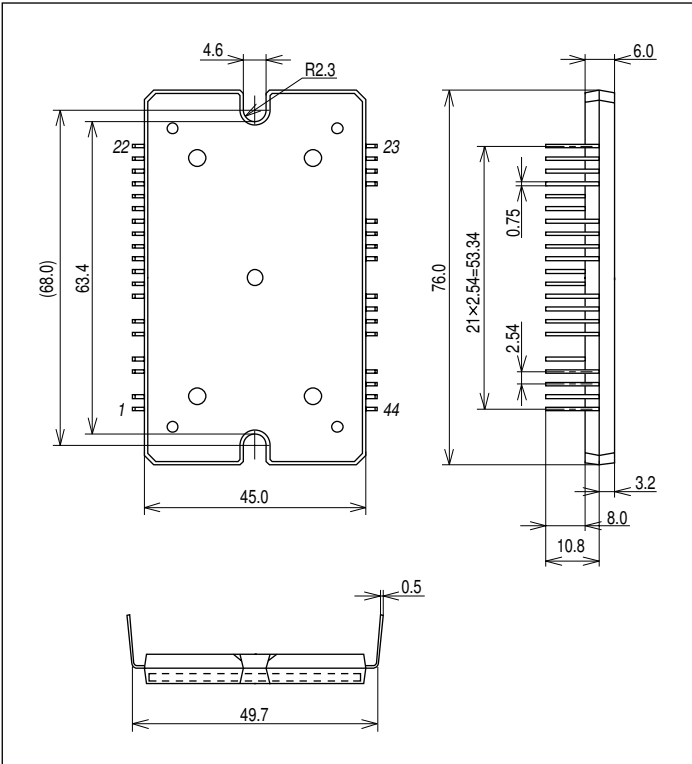

IGBT (TR1+TR2), FRD1 (D2+D3) & FRD2 (D4) vs. Temperature Derating ($T_a = 25^\circ\text{C}$)

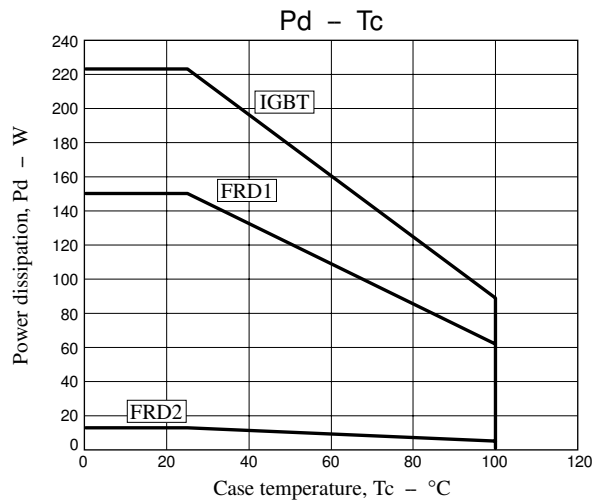

Block Diagram

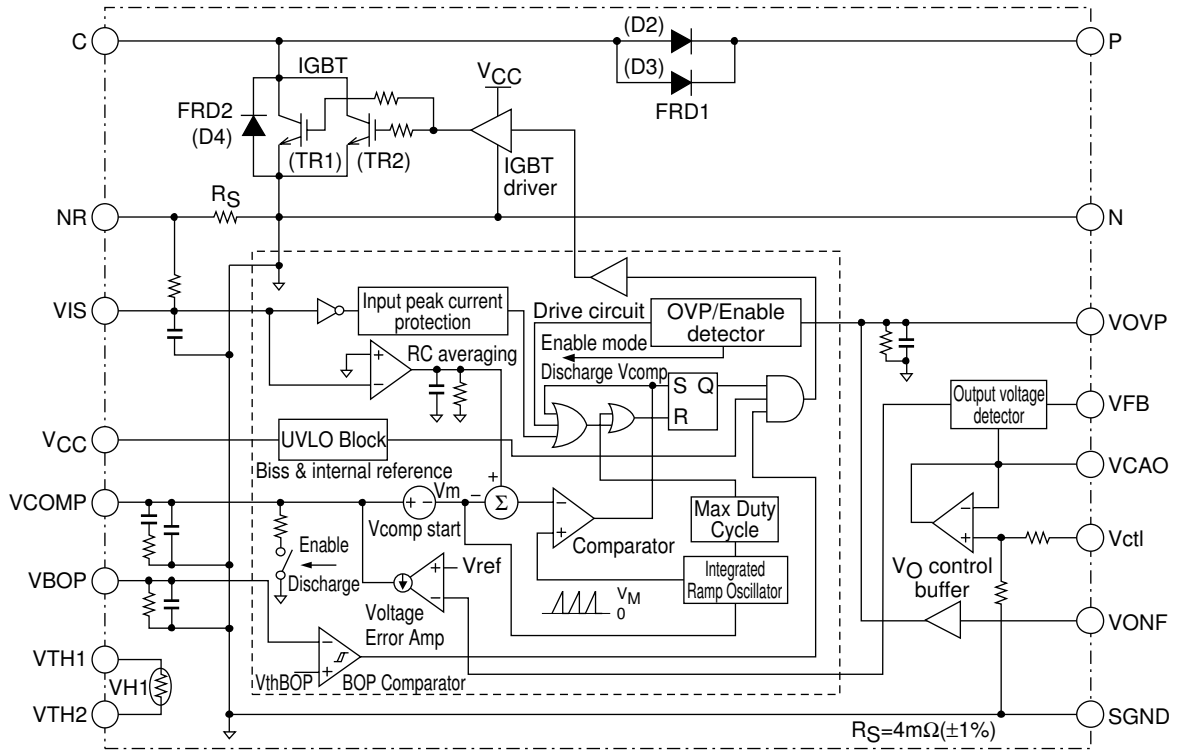

Explanation of Terminal

Terminal No.	Symbol	Explanation
1	VBOP	Brown-out fault detection terminal
2	VCC	Control IC power supply input
3	-	An empty terminal
4	VONF	ON/OFF control terminal
5	GND	Signal GND
6	-	An empty terminal
7	VIS	Current detection terminal
8	VCOMP	Phase compensation terminal (Voltage error amplifier out)
9	-	An empty terminal
10	Vctl	Output voltage control signal input
11	VCAO	Output voltage control amplifier output
12	VFB	Output voltage feed back terminal
13	VOVP	Over voltage protection terminal
14	VTH1	Terminal of thermistor TH1
15	VTH2	Terminal of thermistor TH1
16 to 22	-	A dummy terminal
23 to 26	P	Output (+) terminal of PFC
27, 28	-	An empty terminal
29 to 32	C	IGBT (TR1+TR2) Collector
33,34	-	An empty terminal
35 to 38	N	Output (-) terminal of PFC
39, 40	-	An empty terminal
41 to 44	NR	Input current return terminal

Test Circuit -1

(1) I_{CES} , I_R

	IGBT	FRD1
A	29, 30, 31, 32	23, 24, 25, 26
B	35, 36, 37, 38	29, 30, 31, 32

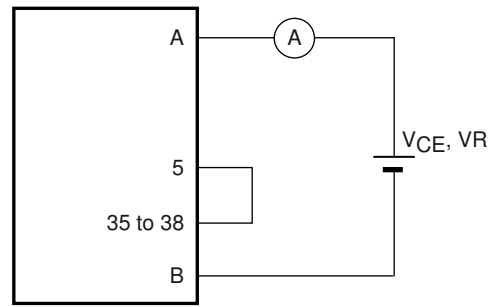

(Fig.1)

(2) $V_{CE(sat)}$ (Test by Pulse)

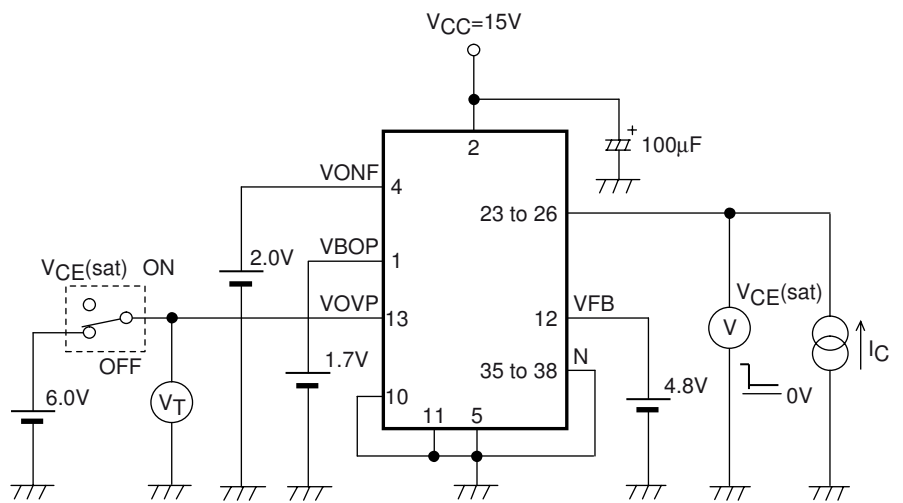

(Fig.2)

(3) V_{F1} , V_{F2} (Test by Pulse), R_{TH}

	FRD1	FRD2
A	29, 30, 31, 32	35, 36, 37, 38
B	23, 24, 25, 26	29, 30, 31, 32

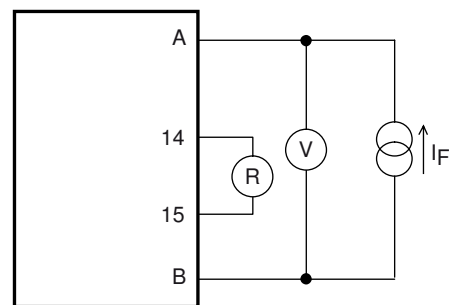

(Fig.3)

Test Circuit -2

(4) $I_{CC(ON)}/I_{CC(OFF)}$, VOLP, f_{OSC}

I_{CC}, f_{OSC}	VOLP
VFB = 1.1V	VONF = 5.0V

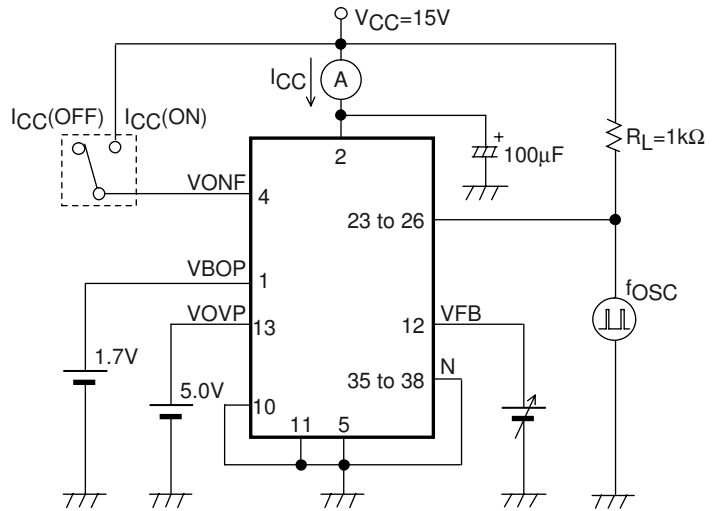

(Fig.4)

(5) V_{ref} , VIS(PK)

V_{ref}	VIS(PK)
VIS = -0.6V	VFB = 4.8V

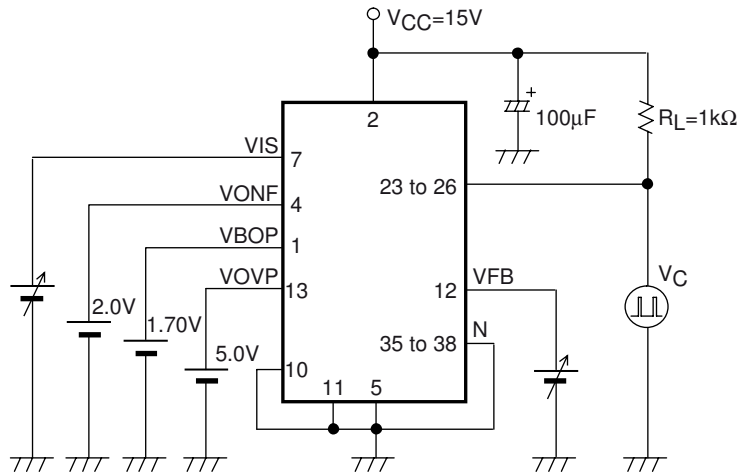

(Fig.5)

(6) $VOVP(ON)$, $VBOP(ON)$

$VOVP(ON)$	$VBOP(ON)$
$VBOP = 1.70V$	$VOVP = 5.0V$

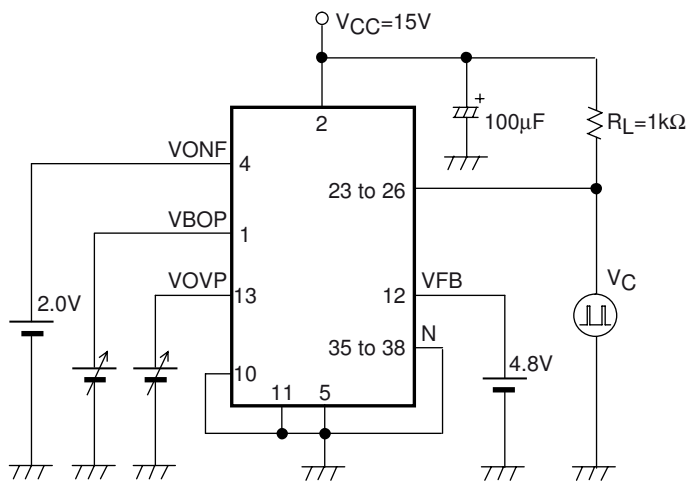

(Fig.6)

Test Circuit -3

(7) VTHON, VTHOFF

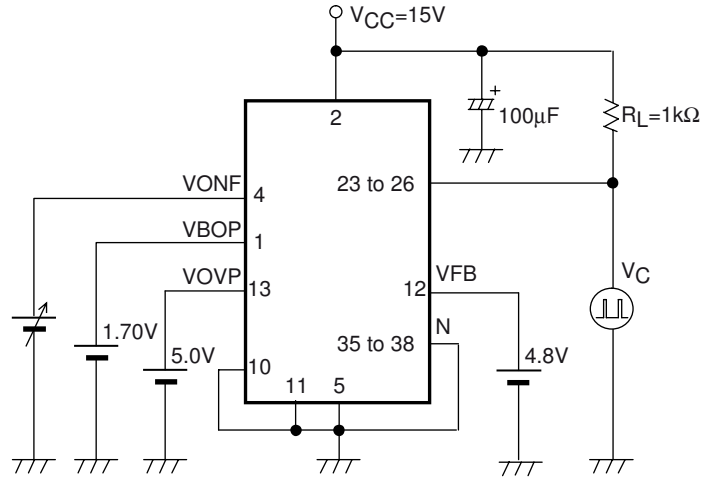

(Fig.7)

(8) VCC(ON), VCC(OFF)

VCC(ON)	VCC(OFF)
Vc-ON	Vc-OFF

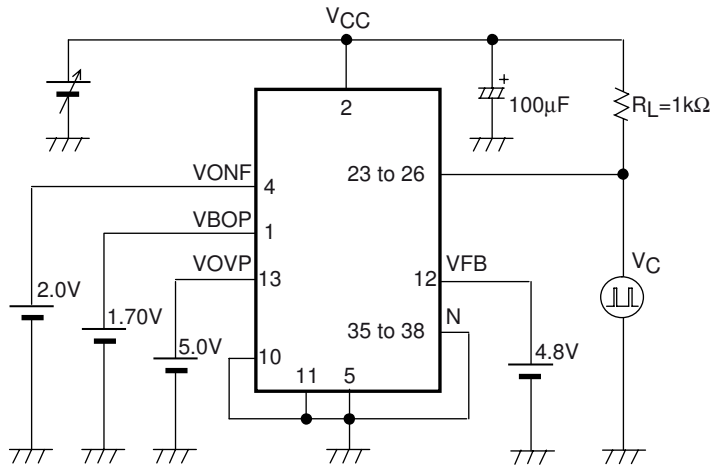

(Fig.8)

(9) Power Factor (COSφ)

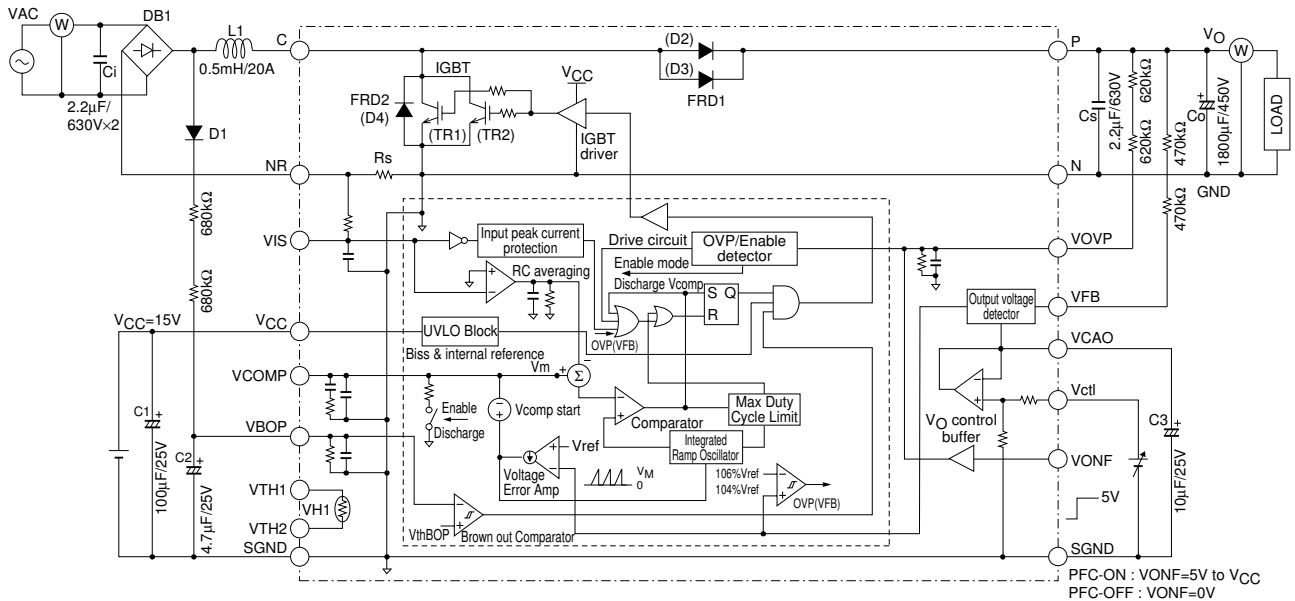

(Fig.9)

Application Circuit

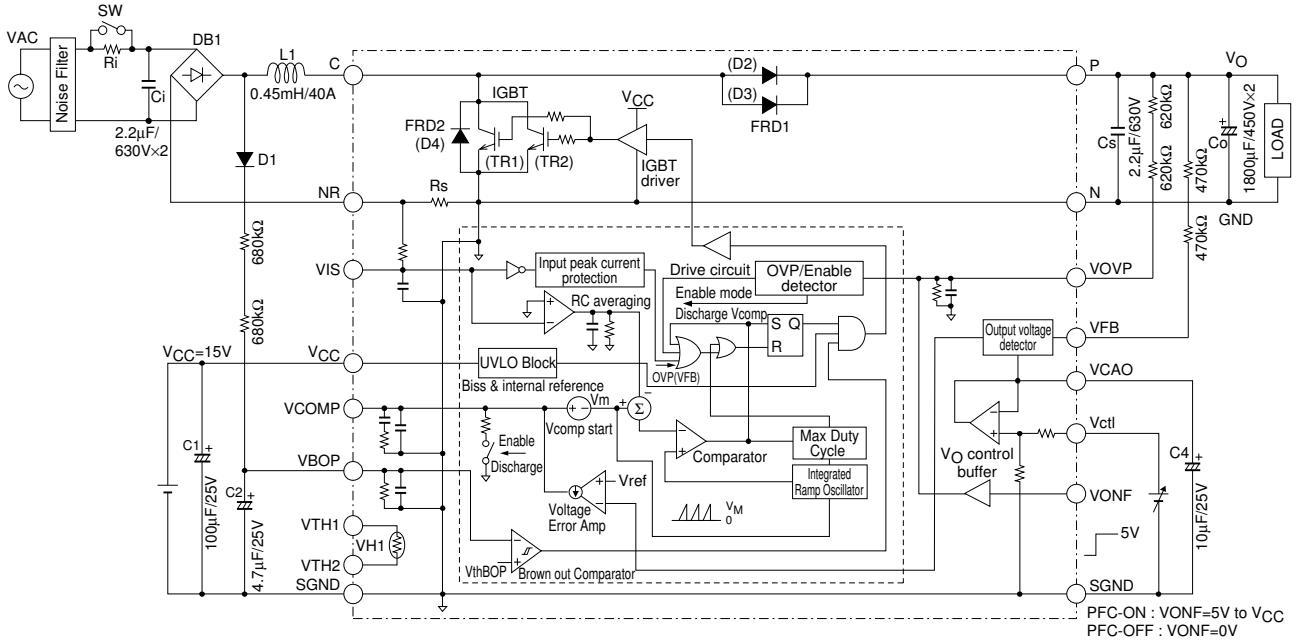

Recommended Condition

Parameter	Symbol	Conditions	Ratings	unit
AC Voltage	VAC	50/60Hz	170 to 264	Vrms
Output voltage	VO		$VAC \times \sqrt{2} + (10 \text{ to } 15) \leq 450$	V
Over-voltage detection voltage	VOV		$VO_{UT} + (10 \text{ to } 20)$	V
Control IC supply voltage	VCC	VCC-GND	14.5 to 17.0	V
Inductor	L1		0.45	mH
Input film capacitor	Ci		$4.4 \leq Ci$	μF
Output film capacitor	Cs		$4.4 \leq Cs$	μF
Output electrolytic capacitor	Co		$3600 \leq Co$	μF

Output Voltage Control

Output voltage control signal Vctl sets referring to the Vctl-VO characteristic of the figure below.

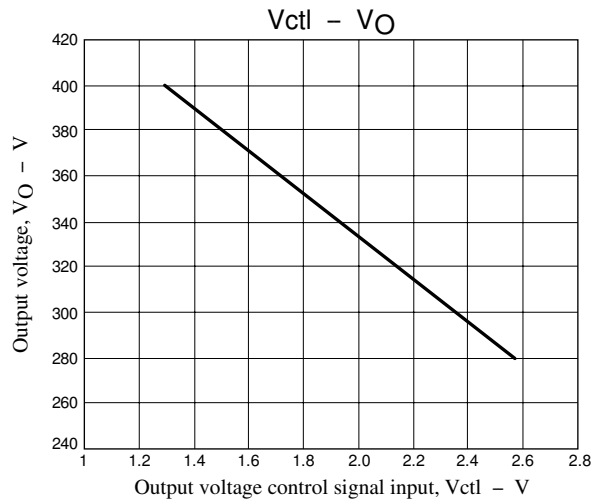

Timing Chart

Even if power supply and signal at any timing are input, this IC is not destroyed. However, soft start circuit doesn't operate when V_{IN} (DC) is input at the timing of Figure 11 and 12. Therefore, overcurrent protection circuit will operate, and audio frequency noise from coil may generate. Please turn on ON/OFF or V_{CC} after V_{IN} (DC) to avoid this.

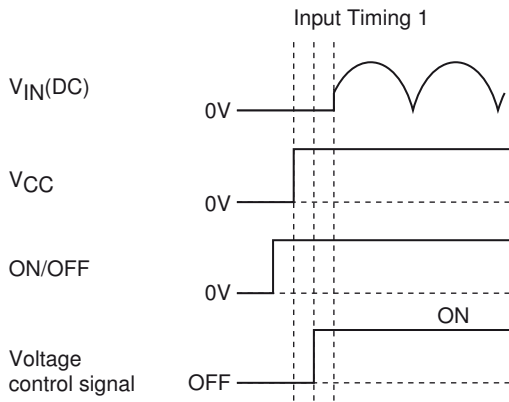

<Fig.11>

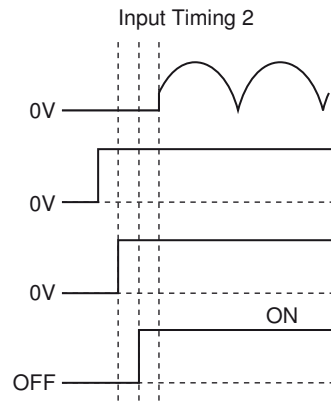

<Fig.12>

The built-in thermistor resistance temperature characteristic

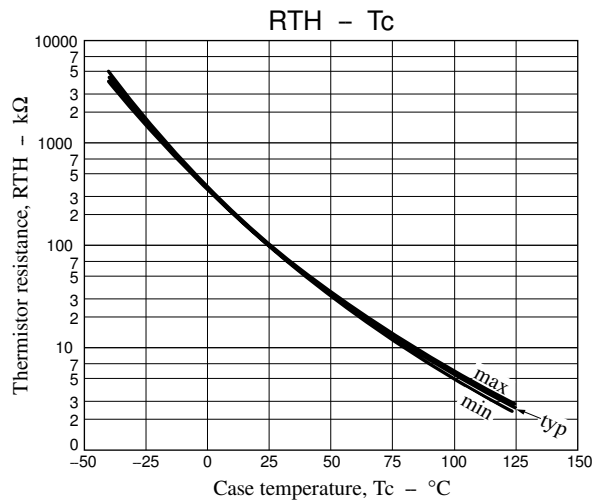

- SANYO Semiconductor Co.,Ltd. assumes no responsibility for equipment failures that result from using products at values that exceed, even momentarily, rated values (such as maximum ratings, operating condition ranges, or other parameters) listed in products specifications of any and all SANYO Semiconductor Co.,Ltd. products described or contained herein.
- Regarding monolithic semiconductors, if you should intend to use this IC continuously under high temperature, high current, high voltage, or drastic temperature change, even if it is used within the range of absolute maximum ratings or operating conditions, there is a possibility of decrease reliability. Please contact us for a confirmation.
- SANYO Semiconductor Co.,Ltd. strives to supply high-quality high-reliability products, however, any and all semiconductor products fail or malfunction with some probability. It is possible that these probabilistic failures or malfunction could give rise to accidents or events that could endanger human lives, trouble that could give rise to smoke or fire, or accidents that could cause damage to other property. When designing equipment, adopt safety measures so that these kinds of accidents or events cannot occur. Such measures include but are not limited to protective circuits and error prevention circuits for safe design, redundant design, and structural design.
- In the event that any or all SANYO Semiconductor Co.,Ltd. products described or contained herein are controlled under any of applicable local export control laws and regulations, such products may require the export license from the authorities concerned in accordance with the above law.
- No part of this publication may be reproduced or transmitted in any form or by any means, electronic or mechanical, including photocopying and recording, or any information storage or retrieval system, or otherwise, without the prior written consent of SANYO Semiconductor Co.,Ltd.
- Any and all information described or contained herein are subject to change without notice due to product/technology improvement, etc. When designing equipment, refer to the "Delivery Specification" for the SANYO Semiconductor Co.,Ltd. product that you intend to use.
- Upon using the technical information or products described herein, neither warranty nor license shall be granted with regard to intellectual property rights or any other rights of SANYO Semiconductor Co.,Ltd. or any third party. SANYO Semiconductor Co.,Ltd. shall not be liable for any claim or suits with regard to a third party's intellectual property rights which has resulted from the use of the technical information and products mentioned above.

This catalog provides information as of October, 2012. Specifications and information herein are subject to change without notice.