



SANYO Semiconductors

# DATA SHEET

An ON Semiconductor Company

## STK611-721-E — Thick-Film Hybrid IC Fan 3-phase Inverter Motor Drive Inverter Hybrid IC

### Overview

This "Inverter Power H-IC" includes the output stage of a 3-phase inverter, pre-drive circuits, as well as protection circuits in one package.

### Applications

- For 3-phase motor drive for fan etc.

### Features

- Pre-drive low voltage protection circuits are built in.
- Direct input of CMOS level control signals without insulating circuits is possible.(Active HIGH)
- Built-in simultaneous upper/ lower ON prevention circuit to prevent arm shorting caused by simultaneous ON input for the upper and lower side transistors.  
(Dead time is required for preventing shorting due to switching delay.)
- Overcurrent protection is possible by connecting a shunt resistor externally.
- Monitoring substrate temperature is possible through the use of an internal thermistor.

■ Any and all SANYO Semiconductor Co.,Ltd. products described or contained herein are, with regard to "standard application", intended for the use as general electronics equipment. The products mentioned herein shall not be intended for use for any "special application" (medical equipment whose purpose is to sustain life, aerospace instrument, nuclear control device, burning appliances, transportation machine, traffic signal system, safety equipment etc.) that shall require extremely high level of reliability and can directly threaten human lives in case of failure or malfunction of the product or may cause harm to human bodies, nor shall they grant any guarantee thereof. If you should intend to use our products for new introduction or other application different from current conditions on the usage of automotive device, communication device, office equipment, industrial equipment etc. , please consult with us about usage condition (temperature, operation time etc.) prior to the intended use. If there is no consultation or inquiry before the intended use, our customer shall be solely responsible for the use.

■ Specifications of any and all SANYO Semiconductor Co.,Ltd. products described or contained herein stipulate the performance, characteristics, and functions of the described products in the independent state, and are not guarantees of the performance, characteristics, and functions of the described products as mounted in the customer's products or equipment. To verify symptoms and states that cannot be evaluated in an independent device, the customer should always evaluate and test devices mounted in the customer's products or equipment.

# STK611-721-E

## Specifications

### Absolute Maximum Ratings at $T_c = 25^\circ\text{C}$

Parameter	Symbol	Conditions	Ratings	unit
Supply voltage	$V_{CC}$	+ to -, surge < 450V *1	450	V
Collector-emitter voltage	$V_{DS}$	+ to U (V, W) or U (V, W) to -	600	V
Output current	$I_O$	+, -, U, V, W terminal current	$\pm 2$	A
Output peak current	$I_{op}$	+, -, U, V, W terminal current P.W. = 100 $\mu$ s	$\pm 4$	A
Pre-driver voltage	VD1, 2, 3, 4	VB1 to U, VB2 to V, VB3 to W, $V_{DD}$ to $V_{SS}$ *2	20	V
Input signal voltage	$V_{IN}$	HIN1, 2, 3, LIN1, 2, 3 terminal	0 to 15	V
FAULT/EN terminal voltage	VFAULT	FAULT/EN terminal	20	V
ITRIP terminal voltage	VITRIP	ITRIP terminal	5	V
Maximum power dissipation	$P_d$	MOSFET/1 channel	16.6	W
Junction temperature	$T_j$	MOSFET	150	$^\circ\text{C}$
Storage temperature	$T_{stg}$		-40 to +125	$^\circ\text{C}$
Operating substrate temperature	$T_c$	H-IC case temperature	-20 to +100	$^\circ\text{C}$
Tightening torque		A screw part *3	0.6	N·m

Reference voltage is “-” terminal = “ $V_{SS}$ ” terminal voltage unless otherwise specified.

\*1 Surge voltage developed by the switching operation due to the wiring inductance between “+” and “-” terminals.

\*2 Terminal voltage : VD1=VB1 to U, VD2=VB2 to V, VD3=VB3 to W, VD4= $V_{DD}$  to  $V_{SS}$ .

\*3 Flatness of the heat-sink should be 0.15mm and below.

### Electrical Characteristics at $T_c=25^\circ\text{C}$ , $V_D=15\text{V}$

Parameter	Symbol	Conditions	Test circuit	min	typ	max	unit
Power output section							
Drain-Source Leakage current	$I_{DSS}$	$V_{DS} = 600\text{V}$	Fig.1			0.1	mA
Drain-Source On Resistance	$R_{DS(ON)}$	$I_D = 2\text{A}$	Fig.2			4	$\Omega$
Diode forward voltage	$V_{SD}$	$I_D = -2\text{A}$	Fig.3			1.5	V
Junction to case thermal resistance	$\theta_{j-c(T)}$	MOSFET				7.5	$^\circ\text{C/W}$
Control (Pre-driver) section							
Pre-driver power dissipation	$I_D$	VD1, 2, 3 = 15V	Fig.4		0.05	0.2	mA
		VD4 = 15V			1.4	4.0	
Input ON threshold voltage	$V_{in(th)}$ (on)	HIN1, HIN2, HIN3, LIN1, LIN2,		1.5	2.1	2.5	V
Input OFF threshold voltage	$V_{in(th)}$ (off)	LIN3 to $V_{SS}$		0.8	1.3	1.5	V
FAULT/EN clearness delay time	FLTCLR	After each protection operation ending			8		ms
Protection section							
Pre-drive power supply low voltage protection voltage	UVLO			8		9.8	V
Resistance for substrate temperature monitors	$R_t$	Resistance between TH and $V_{SS}$ terminals		90	100	110	k $\Omega$
Fault/EN terminal input current	$I_{OSD}$	$V_{Fault} = 0.15\text{V}$			2		mA
ITRIP threshold voltage	VITRIP			0.41	0.465	0.52	V
Switching time							
	$t_{ON}$	$I_O = 2\text{A}$ Inductive load	Fig.5		0.8		$\mu\text{s}$
	$t_{OFF}$				1.5		

Reference voltage is “-” terminal = “ $V_{SS}$ ” terminal voltage unless otherwise specified.

# STK611-721-E

## Notes

1. <<Input ON threshold voltage>> indicates the threshold of input signal to turn on output stage MOSFET.  
<<Input OFF threshold voltage>> indicates the threshold of input signal to turn off output stage MOSFET.  
At the time of output ON, set the input signal voltage to  $V_{inH} (on)_{MAX}$  to 15V. At the time of output OFF, set the input signal voltage to 0V to  $V_{inH} (off)_{MIN}$ .
2. When the internal protection circuit operates, a "FAULT/EN" signal is turned ON (When the "FAULT/EN" terminal is low level, "FAULT/EN" signal is ON state: output form is open DRAIN) but the "FAULT/EN" signal does not latch. After protection operation ends, it returns automatically within typ. 8ms and resumes operation beginning condition. So, after "FAULT/EN" signal detection, set all signals to OFF (LOW) at once.  
However, the operation of pre-drive power supply low voltage protection (UVLO with hysteresis about 0.2V) is as follows:  
Upper side : There is no "FAULT/EN" signal output, but a corresponding gate signal is turned OFF. Incidentally, it returns to the regular operation when recovering to the normal voltage, but the latch continues while the input signal is ON (HIGH).  
Lower side : It outputs "FAULT/EN" signal with gate signal OFF. However, it is different from the protection operation of upper side, it is automatically reset and resumes operation beginning condition when recovering to normal voltage. (The protection operation is not latched by the input signal.)
3. When assembling the H-IC on the heat sink, tightening torque range is 0.4N•m to 0.6•Nm.
4. The pre-drive low voltage protection is the function to protect devices when the pre-drive supply voltage declines with an operating malfunction. As for the pre-driver supply voltage decline in case of operation beginning, and so on, check it in your set.
5. Please seal the entire leads of H-IC with the resin for securing the insulation between leads after mounting H-IC on the set.

## Package Dimensions

unit:mm (typ)

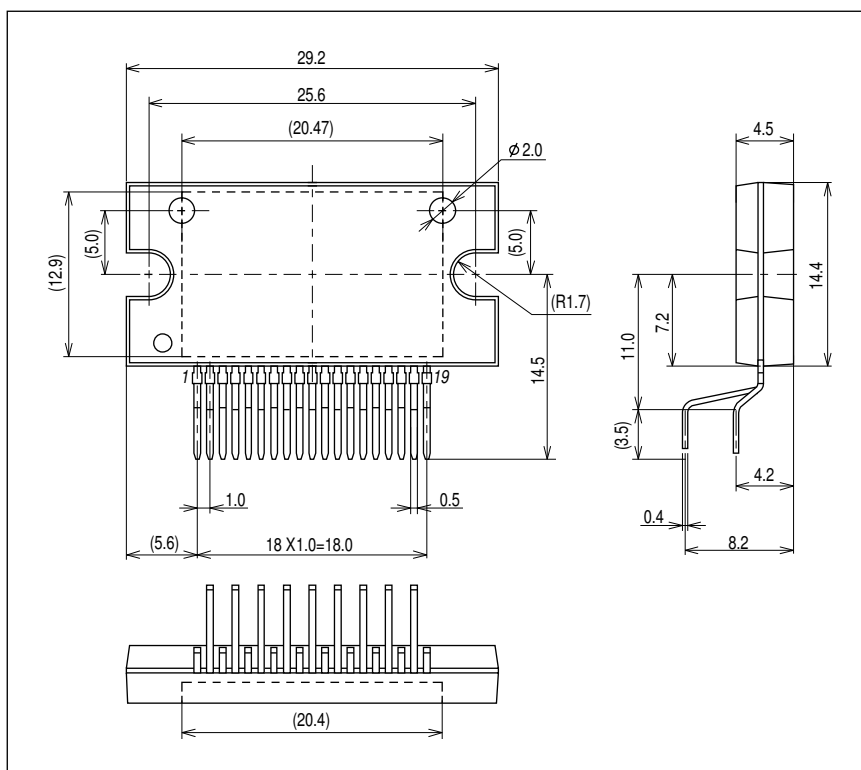

Equivalent Block Diagram

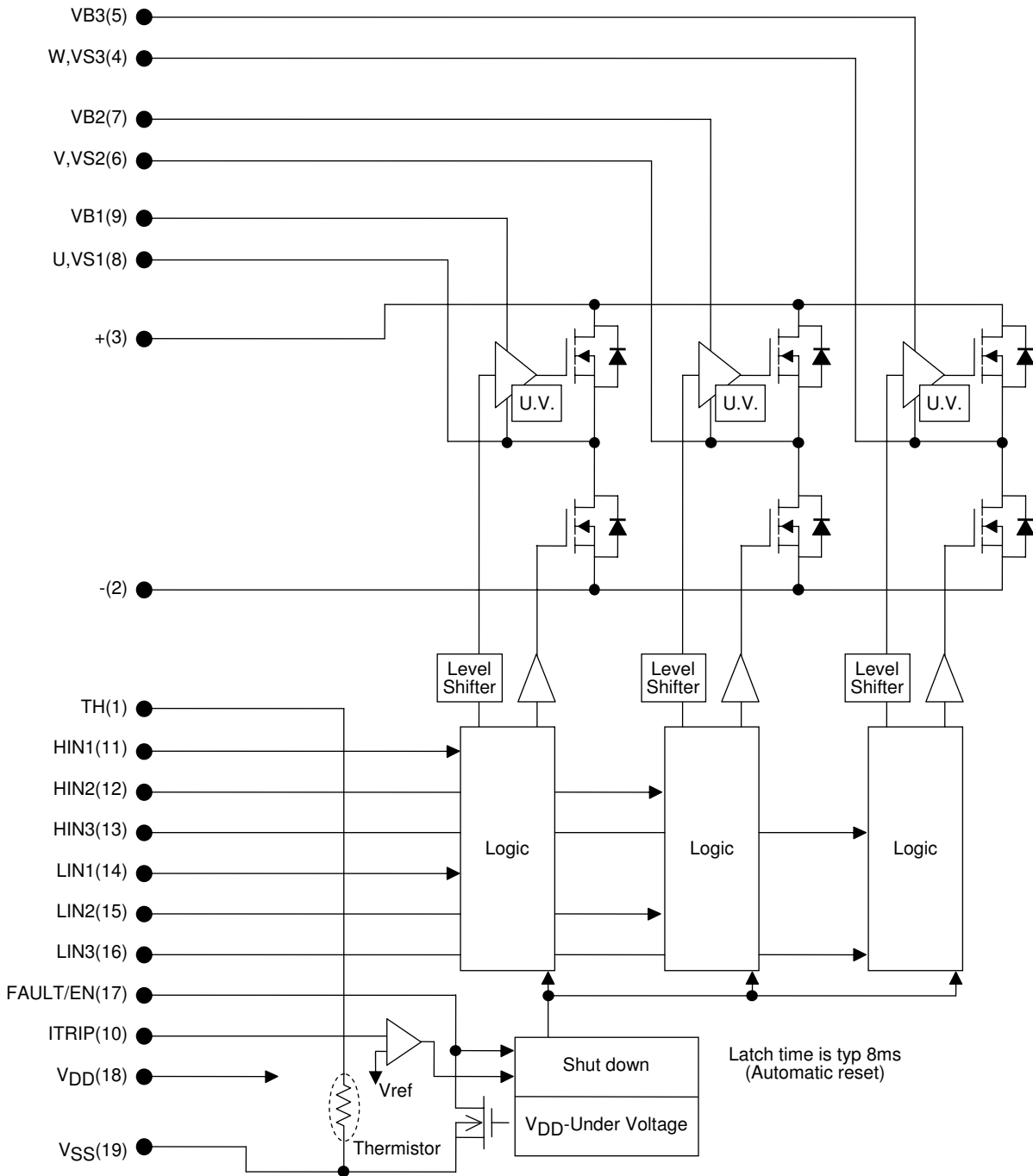

**Test Circuit**

(The tested phase: U+ shows the upper side of the U phase and U- shows the lower side of the U phase.)

**I<sub>DSS</sub>**

	U+	V+	W+	U-	V-	W-
M	3	3	3	8	6	4
N	8	6	4	2	2	2

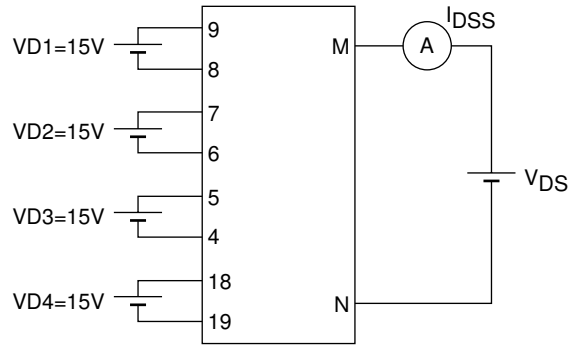

Fig.1

**V<sub>DS</sub> (RDS) (Test by pulse)**

	U+	V+	W+	U-	V-	W-
M	3	3	3	8	6	4
N	8	6	4	2	2	2
m	11	12	13	14	15	16

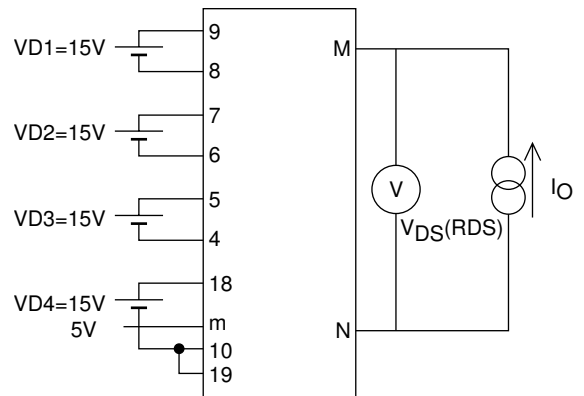

Fig.2

**V<sub>F</sub> (Test by pulse)**

	U+	V+	W+	U-	V-	W-
M	3	3	3	8	6	4
N	8	6	4	2	2	2

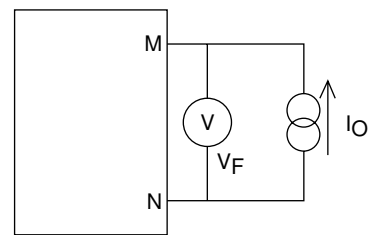

Fig.3

**I<sub>D</sub>**

	VD1	VD2	VD3	VD4
M	9	7	5	18
N	8	6	4	19

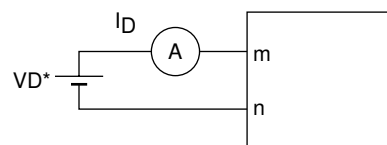

Fig.4

# STK611-721-E

Switching time (The circuit is a representative example of the lower side U phase.)

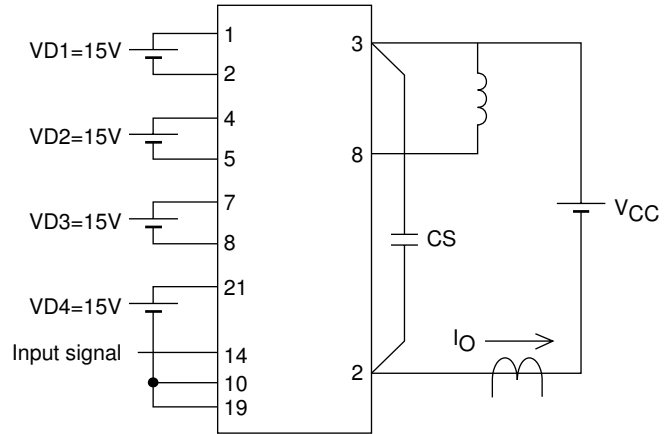
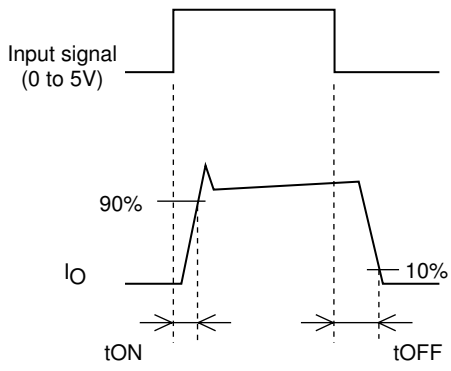
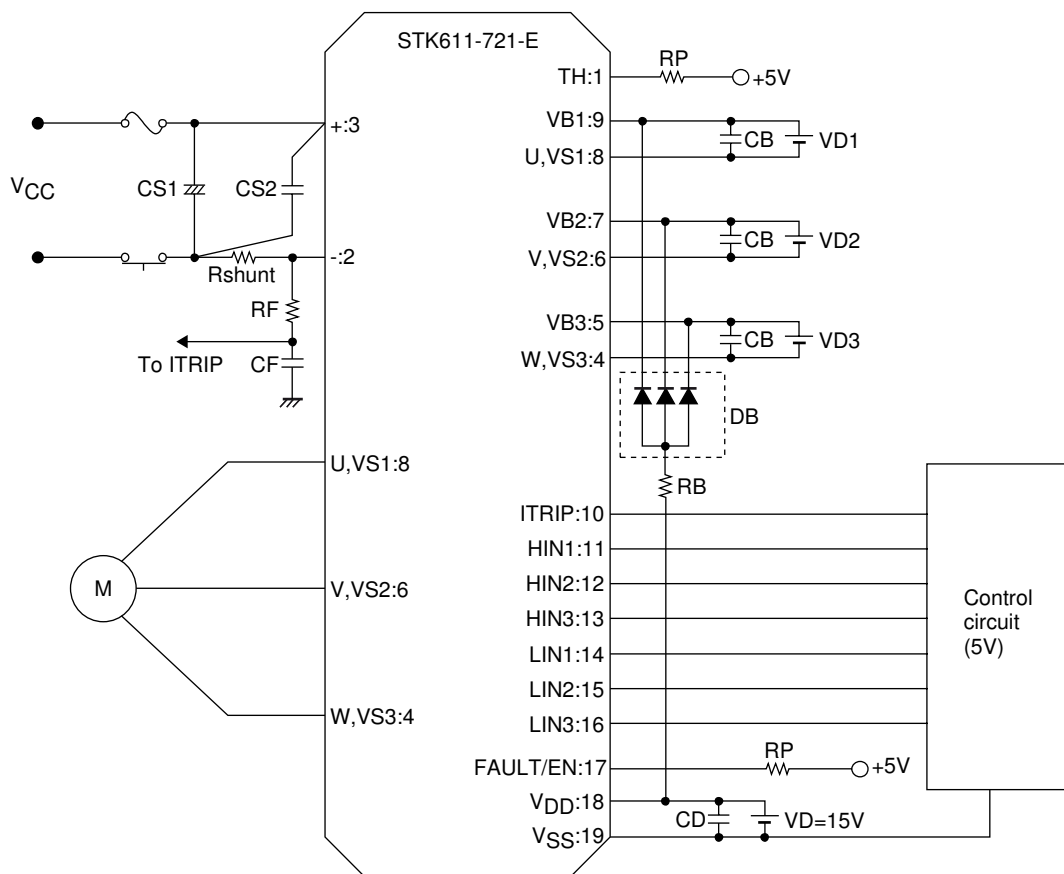

Fig.5

# STK611-721-E

## Sample Application Circuit



### Recommendation Operating Conditions

Parameter	Symbol	Conditions	min	typ	max	unit
Supply voltage	$V_{CC}$	+ to - terminal	0		400	V
Pre-driver supply voltage	VD1, 2, 3	VB1 to U, VB2 to V, VB3 to W	12.5	15	17.5	V
	VD4	$V_{DD}$ to $V_{SS}$ *1	13.5	15	16.5	
ON-state input voltage	$V_{IN(ON)}$	HIN1, HIN2, HIN3, LIN1, LIN2, LIN3	3.0		5.0	V
OFF-state input voltage	$V_{IN(OFF)}$		0		0.3	
PWM frequency	fPWM		1		20	kHz
Dead time	DT	Turn-off to turn-on	2			$\mu$ s
Allowable input pulse width	PWIN	ON and OFF	1			$\mu$ s
Tightening torque		'M3' type screw	0.4		0.6	N·m

\*1 Pre-driver power supply ( $VD4 = 15 \pm 1.5V$ ) must have the capacity of  $I_O = 20mA$  (DC), 0.5A (Peak).

## Usage Precaution

1. By the addition of the diode for the bootstrap (DB : high speed type with withstand voltage of 600V or more) and of the capacitor (CB : about 1 to 47 $\mu$ F), a single power supply drive is enabled. In this case, an electric charge is charged to CB by turning on the lower side IGBT (By inputting LOW signal to lower side). The problem of causing the adverse effect by the noise etc. might occur because big charging current flows when the voltage of CB is low as started, and put limitation resistor RB (About tens of  $\Omega$  from the number of  $\Omega$ ), please. (When not using bootstrap circuit, each upper side pre-driver needs an external independent power supply.) Also, the upper side power supply voltage sometimes declines depending on controlling condition. Please confirm the voltage with an actual set.
2. The voltage jump associated with vibration caused by the switching operation occurs through the influence of floating inductance on the wiring of the external power supply, which is connected to “+” and “-” terminals; therefore, it is recommended that the wiring inductance be low by shortening the wiring length (between CI and each terminal) and the snubber circuit (capacitor/CS/about 0.1 to 10 $\mu$ F) for voltage absorption be connected as close as possible between “+” and “-” terminals to reduce the surge voltage.
3. Output form of “FAULT/EN” terminal (pin 17) is open DRAIN (it operates as “FAULT” when becoming “LOW”). Moreover, please connect the pull-up resistor (RP) so that the voltage of this terminal may usually become 2.5V or more because this terminal holds the shutdown input of internal pre-driver (It usually operates by 2.5V or more, and stop operation by 0.8V or less) concurrently. When the pull-up voltage is 5V, use RP with resistance 6.8k $\Omega$  or more, and in case of 15V, use RP with resistance 20k $\Omega$  or more.
4. Inside the H-IC, a thermistor is connected between “TH” terminal (pin 1) and “VSS” terminal (pin 19). The thermistor can be used as the temperature monitor by connecting the pull-up resistor (RP) externally. When the pull-up voltage is 5V, use “RP” with resistance 10k $\Omega$  or more, and in case of 15V, use “RP” with resistance 39k $\Omega$  or more.
5. Although the pull-down resistor is connected with the inside of the signal input terminal, connect the pull-down resistor (about 2.2 to 3.3k $\Omega$ ) outside to decrease the influence of the noise by wiring etc.
6. The H-IC may be destroyed when the motor connection terminals (pins 4, 6 and 8) are opened while the motor is running; therefore please be especially careful about the connection (soldering condition) of these terminals.
7. The “ITRIP” terminal (pin 16) is the input terminal of the built-in comparator. It can stop operation by inputting the voltage more than VITRIP (0.41V to 0.52V). (Apply voltage less than VITRIP to this pin when normal operation). Please use it as various protections such as the overcurrent protection (feedback from external shunt resistor). In addition, the protection operation will not be latched. After the protection operation ends, the H-IC operation resumes typ.8ms later. Therefore, turn all the input signals OFF (low) as soon as the protection operation is detected.
8. When input pulse width is less than 1 $\mu$ s, an output may not react to the pulse. (Both ON signal and OFF signal)

This data shows the example of the application circuit and does not guarantee a design as the mass production set.

- SANYO Semiconductor Co.,Ltd. assumes no responsibility for equipment failures that result from using products at values that exceed, even momentarily, rated values (such as maximum ratings, operating condition ranges, or other parameters) listed in products specifications of any and all SANYO Semiconductor Co.,Ltd. products described or contained herein.
- Regarding monolithic semiconductors, if you should intend to use this IC continuously under high temperature, high current, high voltage, or drastic temperature change, even if it is used within the range of absolute maximum ratings or operating conditions, there is a possibility of decrease reliability. Please contact us for a confirmation.
- SANYO Semiconductor Co.,Ltd. strives to supply high-quality high-reliability products, however, any and all semiconductor products fail or malfunction with some probability. It is possible that these probabilistic failures or malfunction could give rise to accidents or events that could endanger human lives, trouble that could give rise to smoke or fire, or accidents that could cause damage to other property. When designing equipment, adopt safety measures so that these kinds of accidents or events cannot occur. Such measures include but are not limited to protective circuits and error prevention circuits for safe design, redundant design, and structural design.
- In the event that any or all SANYO Semiconductor Co.,Ltd. products described or contained herein are controlled under any of applicable local export control laws and regulations, such products may require the export license from the authorities concerned in accordance with the above law.
- No part of this publication may be reproduced or transmitted in any form or by any means, electronic or mechanical, including photocopying and recording, or any information storage or retrieval system, or otherwise, without the prior written consent of SANYO Semiconductor Co.,Ltd.
- Any and all information described or contained herein are subject to change without notice due to product/technology improvement, etc. When designing equipment, refer to the "Delivery Specification" for the SANYO Semiconductor Co.,Ltd. product that you intend to use.
- Upon using the technical information or products described herein, neither warranty nor license shall be granted with regard to intellectual property rights or any other rights of SANYO Semiconductor Co.,Ltd. or any third party. SANYO Semiconductor Co.,Ltd. shall not be liable for any claim or suits with regard to a third party's intellectual property rights which has resulted from the use of the technical information and products mentioned above.

This catalog provides information as of October, 2012. Specifications and information herein are subject to change without notice.