



ON Semiconductor®

<http://onsemi.com>

LA1070

Monolithic Linear IC

On-Glass Antenna Amplifier AGC IC

Overview

The LA1070 is an automatic gain control IC for use with automotive on-glass antennas.

Functions

- RF-AGC

Features

- AGC circuit includes a 20dB hysteresis function
- Can implement an FM/AM tuner AGC circuit with just one IC
- AGC circuit provides improved interference characteristics
- Built-in time constant circuit for underbridge countermeasures
- Allows implementation of miniature antenna amplifier modules with a minimal number of external components
- Includes a total of four PIN diode driver circuits

Specifications

Maximum Ratings at Ta = 25°C

Parameter	Symbol	Conditions	Ratings	Unit	
Maximum supply voltage	V _{CC1} Max	The pin 1 voltage (115°C)	9	V	
	V _{CC2} Max (DC)	The pin 14 voltage (115°C)	16	V	
	V _{CC2} Max (Pulse)	The pin 14 voltage (25°C) (*1, *2)	18	V	
Maximum sink current	ITHA	The pin 11 sink current (*1)	2	mA	
Maximum output current	DRV I _{OUT}	(*1)	10	mA	
Maximum current consumption	ICC1 Max	INPUT = 130dBu, VCC1 = 9V, DRV I _{OUT} = 10mA	29	mA	
	ICC2 Max	INPUT = 130dBu, VCC2 = 16V, DRV I _{OUT} = 10mA	29	mA	
Allowable power dissipation	Pd max	INPUT = 130dBu, DRV I _{OUT} = 10mA Circuit board size : 30 × 70 × 1.6(*1)	115°C	320	mW
			25°C	1	W
Operating temperature	Topr		-40 to +115	°C	
Storage temperature	Tstg		-55 to +150	°C	

*1: The stipulated Pdmax must not be exceeded.

*2: Ten cycles with V_{Hi} = 18V for 1 minute and V_{Lo} = 0V for 9 minutes.

Stresses exceeding Maximum Ratings may damage the device. Maximum Ratings are stress ratings only. Functional operation above the Recommended Operating Conditions is not implied. Extended exposure to stresses above the Recommended Operating Conditions may affect device reliability.

Operating Conditions at Ta = 25°C

Parameter	Symbol	Conditions	Ratings	Unit
Recommended supply voltage 1	V _{CC1}		8	V
Guaranteed operating supply voltage 1	V _{CC1} op	(*1)	7 to 8.8	V
Recommended supply voltage 2	V _{CC2}		12	V
Guaranteed operating supply voltage 2	V _{CC2} op	(*1)	7 to 15.8	V
Maximum allowable RF input	Input max	Pins 2-4, 6, 7, 27-25, 23, 22	130	dBu

*1: The stipulated Pdmax must not be exceeded.

Electrical Characteristics at Ta = 25°C, V_{CC1} = 8.0V, V_{CC2} = 12V in the specified circuit

Parameter	Symbol	Conditions	Frequency (Hz)	Ratings			Unit
				min	typ	max	
Signal detection sensitivity 1	Sen1	The input level when the pin 12 and pin 17 (DRV_OUT) output voltage switches from 10.3V to 0V. The input level when the pin 13 and pin 16 (DRV_OUT) output voltage switches from 0V to 10.3V. (*1)	100K	79	83	87	dBu
			1M	79	83	87	
			110M	79	83	87	
			250M (*2)	89	93	97	
			800M (*2)		91		
Signal detection sensitivity 2	Sen2	The input level when the pin 12 and pin 17 (DRV_OUT) output voltage switches from 0 V to 10.3 V. The input level when the pin 13 and pin 16 (DRV_OUT) output voltage switches from 10.3 V to 0 V. (*1)	100k	99	103	107	dBu
			1M	99	103	107	
			110M	99	103	107	
			250M (*2)	99	103	107	
			800M (*2)		102		
DRV circuit output voltage	V _{OHi}	The high-level output voltage provided by pins 12, 13, 17, and 16 (DRV_OUT).		9.8	10.3	10.8	V
	V _{OLo}	The low-level output voltage provided by pins 12, 13, 17, and 16 (DRV_OUT).			0.1	0.2	V
Latch start time	FFAT	The time from the point the RF signal goes on to the point the pin 12 and 17 output voltage reaches 10% of the saturation voltage.		58	90	122	ms
Latch release time	FFRE	The time from the point the RF signal goes on to the point the pin 12 and 17 output voltage reaches 90% of the saturation voltage.		570	950	1520	ms
Comparator reference voltage 1	Traise	The pin 9 and pin 20 (VREF_OUT) pin output voltage with the pins open		2.2	2.4	2.6	V

Continued on next page.

*1: The DRV circuit depends on VCC. The DRV circuit output voltage (output saturation voltage) varies with the output current setting set with an external resistor. See the internal equivalent circuit diagram for details.

*2: The values at 250MHz and 800MHz are used for the specifications and refer to the "Input circuit when the input signal is in the range 250MHz to 800MHz" in the specified peripheral components circuit diagram and block diagram.

LA1070

Continued from preceding page.

Parameter	Symbol	Conditions	Ratings			Unit
			min	typ	max	
Comparator reference voltage 2	VREF1	The pin 9 and pin 20 (VREF_OUT) pin output voltage with the pins grounded through a 10 k Ω resistor.	1.3	1.5	1.7	V
Temperature fluctuation type voltage output	VREF2	The pin 10 and pin 19 (FM_BIAS) output voltage level Maximum output current = 1 mA	2.6	2.8	3.0	V
Temperature detection circuit output voltage	VTHA1	The pin 11 (THAMAL_OUT) output voltage	7.5	7.9	8	V
	VTHA2	The pin 11 (THAMAL_OUT) output voltage, sink current = 160 μ A, $T_a=115^\circ\text{C}$		0.25	0.35	V
Current drain 1	ICCO1	The VCC1 current drain with no input	15	19	23	mA
Current drain 2	ICCO2	The VCC2 current drain with no input	15	18	21	mA
Temperature detection sensitivity	TTHA	The ambient temperature when pin 11 (THAMAL_OUT) is low. (Design guarantee value)	80	95	110	$^\circ\text{C}$

Package Dimensions

unit : mm (typ)

3222A

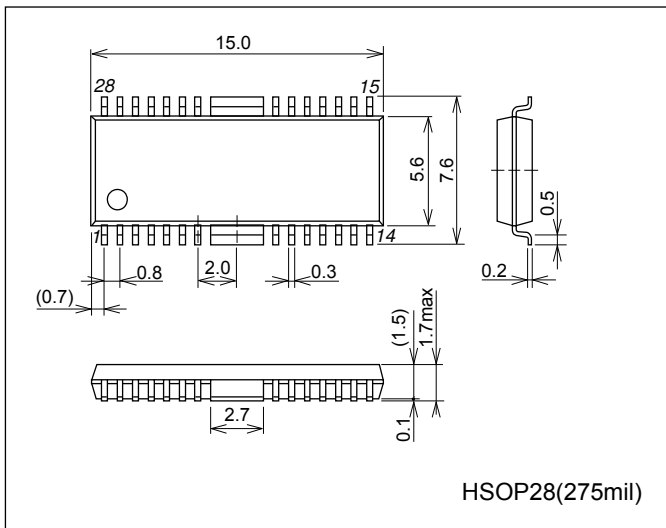

Block Diagram

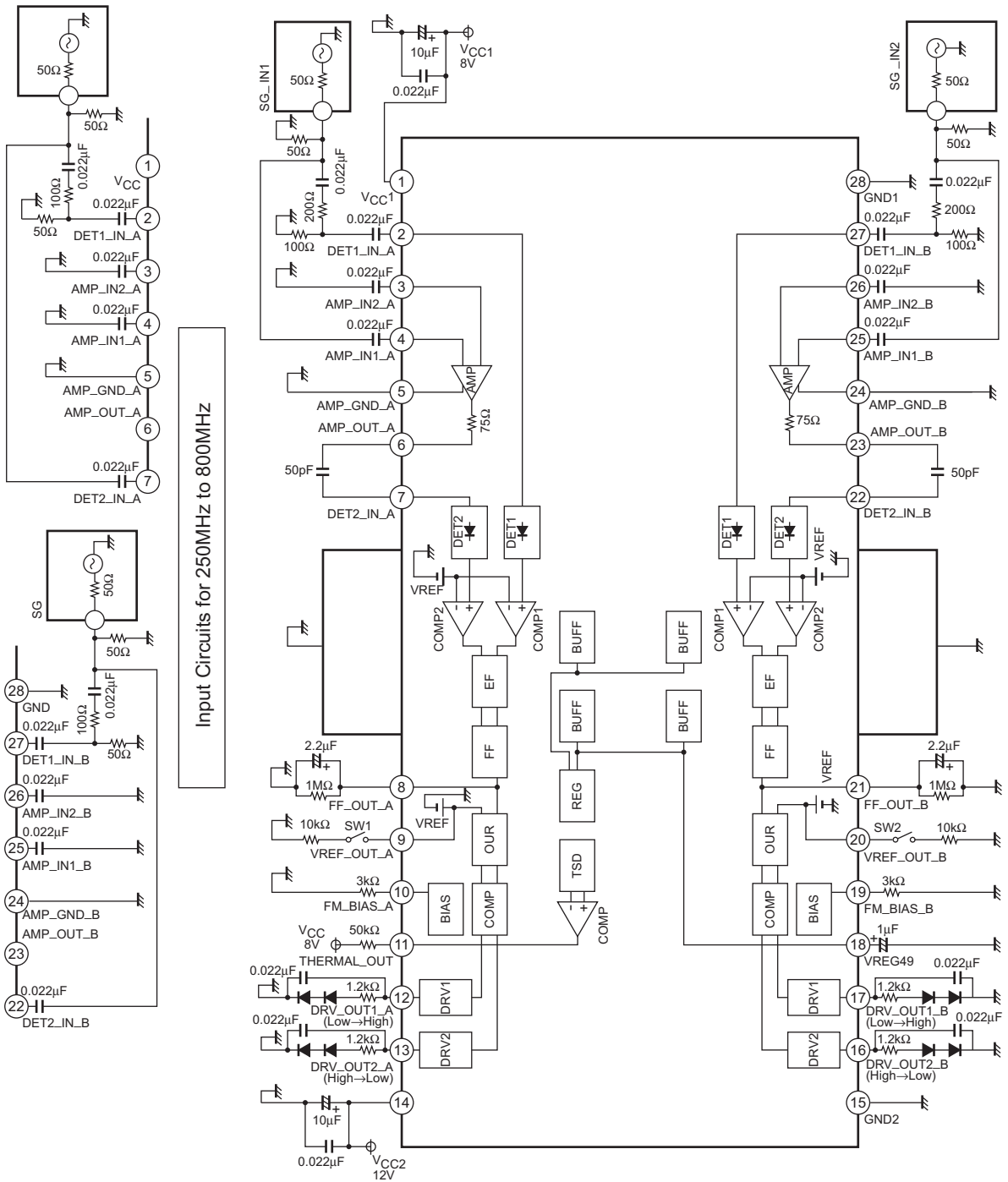

LA1070

Pin Functions and bias voltage (Ta = 25°C)

PIN No.	Pin	Description	Pin bias voltage	Note
1	V _{CC1}	Power supply for circuits other than the DRV circuit	8.00	
2	DET1_IN_A	Detection circuit 1 input	1.85	
3	AMP_IN2_A	Differential amplifier single-sided input	1.87	
4	AMP_IN1_A	Differential amplifier single-sided input	1.87	
5	AMP_GND_A	RF circuit dedicated ground	0	
6	AMP_OUT_A	Differential amplifier output	6.62	
7	DET2_IN_A	Detection circuit 2 input	1.85	
8	FF_OUT_A	Hold circuit and time constant circuit output	0	
9	VREF_OUT_A	Comparator reference voltage output	2.39	
10	FM_BIAS_A	Temperature fluctuation type bias circuit output	2.79	
11	THERMAL_OUT	Temperature detection circuit output	7.97	
12	DRV1_OUT_A	DRV circuit output (low-level output with no input)	0	When set, Low → High
13	DRV2_OUT_A	DRV circuit output (high-level output with no input)	10.30	When set, High → Low
14	V _{CC2}	DRV circuit power supply	12.00	
15	GND2	DRV circuit ground	0	
16	DRV2_OUT_B	DRV circuit output (high-level output with no input)	10.30	When set, High → Low
17	DRV1_OUT_B	DRV circuit output (low-level output with no input)	0	When set, Low → High
18	VREG49	Internal power supply circuit. 4.9V output	4.92	
19	FM_BIAS_B	Temperature fluctuation type bias circuit output	2.78	
20	VREF_OUT_B	Comparator reference voltage output	2.39	
21	FF_OUT_B	Hold circuit and time constant circuit output	0	
22	DET2_IN_B	Detection circuit 2 input	1.85	
23	AMP_OUT_B	Differential amplifier output	6.61	
24	AMP_GND_B	RF circuit dedicated ground	0	
25	AMP_IN1_B	Differential amplifier single-sided input	1.87	
26	AMP_IN2_B	Differential amplifier single-sided input	1.87	
27	DET1_IN_B	Detection circuit 1 input	1.85	
28	GND1	Ground for circuits other than the DRV circuit	0	

LA1070

Pin Equivalent Circuit

Pin No	Pin Function	Equivalent Circuit	Note
3, 4, 26, 25	Amplifier input		AMP $Z_{in} = 2k\Omega$
6, 23	Amplifier output		
7, 22	Detection circuit 2 input		
8, 21	Time constant setting capacitor connection		When a 2.2μF capacitor is used to set the time constant, DRV will be on for 100ms and off for 1 second.
9, 20	Comparator reference voltage output for DRV operation and switching		
10, 19	Temperature fluctuation type bias voltage output		Maximum rated load: 3kΩ

Continued on next page.

LA1070

Continued from preceding page.

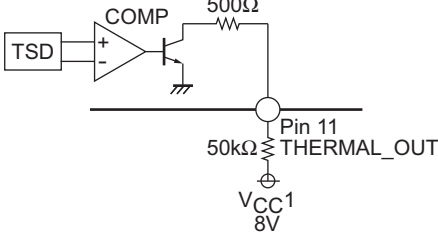
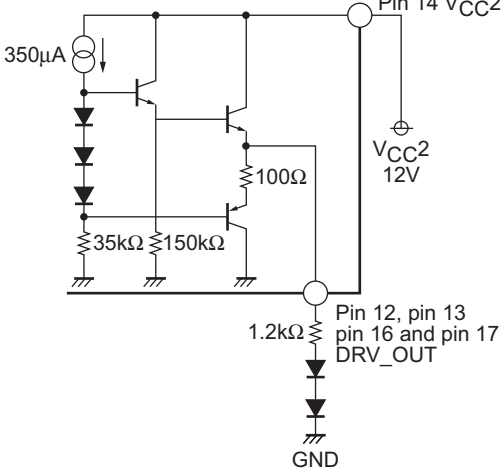
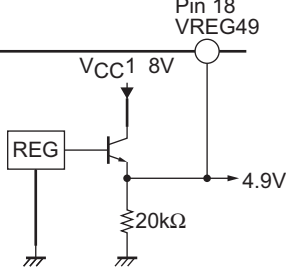
Pin No	Pin Function	Equivalent Circuit	Note
11	Temperature detection circuit output		
12, 13, 16, 17	DRV circuit output		V _{CC} dependent type voltage output circuit
18	Bandgap regulator bypass capacitor connection		Recommended capacitance: 1μF

ON Semiconductor and the ON logo are registered trademarks of Semiconductor Components Industries, LLC (SCILLC). SCILLC owns the rights to a number of patents, trademarks, copyrights, trade secrets, and other intellectual property. A listing of SCILLC's product/patent coverage may be accessed at www.onsemi.com/site/pdf/Patent-Marking.pdf. SCILLC reserves the right to make changes without further notice to any products herein. SCILLC makes no warranty, representation or guarantee regarding the suitability of its products for any particular purpose, nor does SCILLC assume any liability arising out of the application or use of any product or circuit, and specifically disclaims any and all liability, including without limitation special, consequential or incidental damages. "Typical" parameters which may be provided in SCILLC data sheets and/or specifications can and do vary in different applications and actual performance may vary over time. All operating parameters, including "Typicals" must be validated for each customer application by customer's technical experts. SCILLC does not convey any license under its patent rights nor the rights of others. SCILLC products are not designed, intended, or authorized for use as components in systems intended for surgical implant into the body, or other applications intended to support or sustain life, or for any other application in which the failure of the SCILLC product could create a situation where personal injury or death may occur. Should Buyer purchase or use SCILLC products for any such unintended or unauthorized application, Buyer shall indemnify and hold SCILLC and its officers, employees, subsidiaries, affiliates, and distributors harmless against all claims, costs, damages, and expenses, and reasonable attorney fees arising out of, directly or indirectly, any claim of personal injury or death associated with such unintended or unauthorized use, even if such claim alleges that SCILLC was negligent regarding the design or manufacture of the part. SCILLC is an Equal Opportunity/Affirmative Action Employer. This literature is subject to all applicable copyright laws and is not for resale in any manner.