



ON Semiconductor®

<http://onsemi.com>

LA74309FA

Monolithic Linear IC

Microphone Amplifier for Digital Still Camera

Overview

LA74309FA is a microphone amplifier for digital still cameras that have mono audio recording. The analog signal processing for the recording of the digital still camera or other equipment can be easily composed, because the MIC power supply and the ALC circuit are built-in. Moreover, the regulator is built-in, therefore external regulator IC is unnecessary.

Features

- Microphone (MIC) amplifier (+20dB)
- MIC power supply with built-in pull-up resistor
- Automatic level control (ALC) amplifier (output level=-1dBV \approx 2.5Vpp)
- 3rd order LPF (fc=11kHz)
- 3V regulator (At the time of $V_{CC}=3.3V$, internal supply voltage: $V_{CCA}\approx 3.0V$)
- Standby control ($I_{CC}\leq 10\mu A$)

Specifications

Absolute Maximum Ratings at $T_a=25^\circ C$

Parameter	Symbol	Conditions	Ratings	Unit
Maximum power supply voltage	V_{CC} max		4.0	V
Allowable power dissipation	P_d max	$T_a\leq 85^\circ C$	50	mW
Operating temperature	T_{opr}		-20 to +85	$^\circ C$
Storage temperature	T_{stg}		-55 to +150	$^\circ C$

Caution 1) Absolute maximum ratings represent the value which cannot be exceeded for any length of time.

Caution 2) Even when the device is used within the range of absolute maximum ratings, as a result of continuous usage under high temperature, high current, high voltage, or drastic temperature change, the reliability of the IC may be degraded. Please contact us for the further details.

Stresses exceeding Maximum Ratings may damage the device. Maximum Ratings are stress ratings only. Functional operation above the Recommended Operating Conditions is not implied. Extended exposure to stresses above the Recommended Operating Conditions may affect device reliability.

LA74309FA

Operating Conditions at $T_a = 25^\circ\text{C}$

Parameter	Symbol	Conditions	Ratings	Unit
Recommended power supply voltage	V_{CC}		3.3	V
Operating voltage range of V_{CC}	V_{CCop}		3.1 to 3.6	V

Electrical Characteristics at $T_a=25^\circ\text{C}$, $V_{CC}=3.3\text{V}$, $f=1\text{kHz}$

Parameter	Symbol	Conditions	Ratings			Unit
			min	typ	max	
Circuit current						
V_{CC} no signal current dissipation	I_{CC}	$V_{CC}=3.3\text{V}$, Active mode (Pin3=3V)	3.9	5.3	6.7	mA
V_{CC} standby current dissipation	I_{CCS}	$V_{CC}=3.3\text{V}$, Standby mode (Pin3=0V)			10	μA
REC output system						
Standard REC output level	VOR	$V_{IN}=-49\text{dBV}$ at ALC IN pin (=Standard level)	-10	-9	-8	dBV
Standard REC output distortion	HDR	ALC IN, $V_{IN}=-49\text{dBV}$, THD from to 5th harmonic		0.1	0.2	%
ALC characteristics	ALM	ALC IN, $V_{IN}=-17\text{dBV}$ (=Standard level +32dB)	-3	-1		dBV
ALC THD	ALMD	ALC IN, $V_{IN}=-17\text{dBV}$ (=Standard level +32dB), THD from to 5th harmonic		0.25	1	%
ALC IN maximum input level	VINRMX	REC output THD \leq 3%			-10	dBV
REC output noise level	VNOR	No signal at MIC IN pin, with JIS-A Filter		-53	-47	dBV
REC output frequency characteristics 1	FEQR1	ALC IN, $V_{IN}=-17\text{dBV}$, The output level ratio at $f=11\text{kHz}/1\text{kHz}$	-5	-3	-1	dB
REC output frequency characteristics 2	FEQR2	ALC IN, $V_{IN}=-17\text{dBV}$, The output level ratio at $f=22\text{kHz}/1\text{kHz}$		-18	-12	dB
REC output frequency characteristics 3	FEQR3	ALC IN, $V_{IN}=-17\text{dBV}$, The output level ratio at $f=100\text{kHz}/1\text{kHz}$		-55	-45	dB
MIC output system						
MIC voltage gain	VGMIC	$V_{IN}=-39\text{dBV}$ at MIC IN pin	19	20	21	dB
MIC output THD	HDMIC	MIC IN, $V_{IN}=-39\text{dBV}$, THD from to 5th harmonic		0.03	0.1	%
MIC IN maximum input level	VINMMX	MIC output THD=3%			-30	dBV
MIC V_{CC} output DC voltage	VMIC	With 6.2k Ω load	1.5	1.7	1.9	V

Package Dimensions

unit : mm (typ)

3428

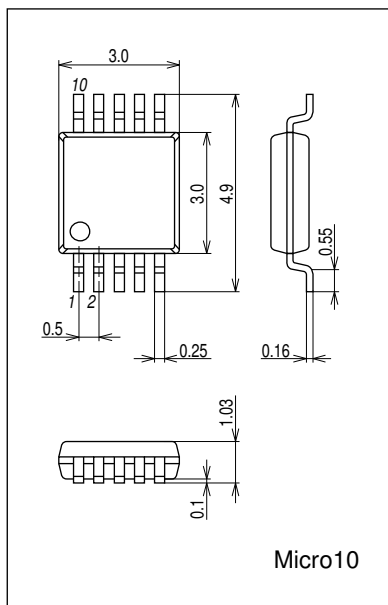

LA74309FA

Pin assignment

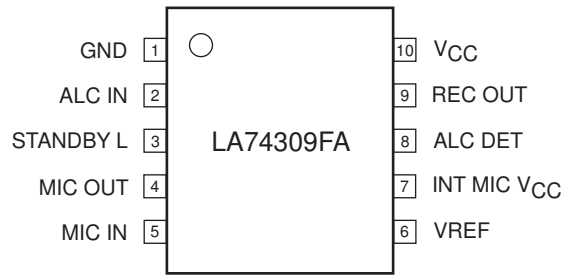

Pin Description

Pin No.	Pin Description
1	GND
2	ALC input
3	STANDBY CTL
4	MIC output
5	MIC input
6	Ripple removal for VREF
7	Internal MIC power supply
8	ALC DET
9	REC output
10	V _{CC}

Equivalent Circuit Block Diagram & Application Circuit

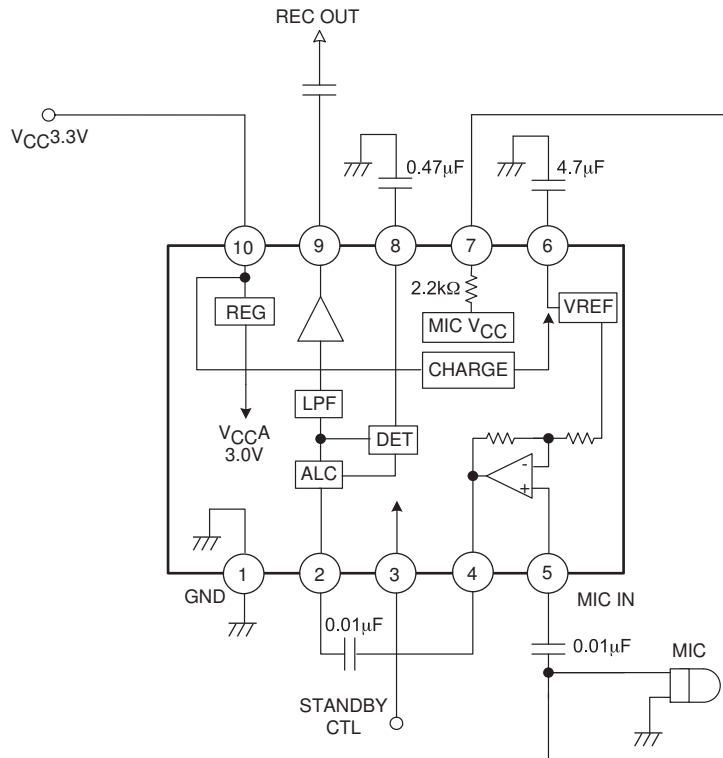

LA74309FA

Pin Functions

PIN No.	Pin Name	DC voltage	AC voltage	Functions	Equivalent Circuit
1	GND	0V		Ground	
2	ALC IN		Output level=-49dBV (At MIC IN=-69dBV) Maximum input level =-10dBV		
3	STANDBY L			Standby control pin Over 2V: Standby OFF	
4	MIC OUT	1.60V	Output level=-49dBV (At MIC IN=-69dBV)	MIC output pin	
5	MIC IN		Standard input level =-69dBV Maximum input level =-30dBV	MIC input pin	
6	VREF	2.30V		MIC V _{CC} and ripple rejection pin for VREFL	
7	INT MIC V _{CC}	2.30V		MIC power supply pin	

Continued on next page.

LA74309FA

Continued from preceding page.

PIN No.	Pin Name	DC voltage	AC voltage	Functions	Equivalent Circuit
8	ALC DET			ALC detector pin	
9	REC OUT	1.60V	Output level=-9dBV (At MIC IN=-69dBV)	REC output pin	
10	V _{CC}	3.3V		Power supply pin	

ON Semiconductor and the ON logo are registered trademarks of Semiconductor Components Industries, LLC (SCILLC). SCILLC owns the rights to a number of patents, trademarks, copyrights, trade secrets, and other intellectual property. A listing of SCILLC's product/patent coverage may be accessed at www.onsemi.com/site/pdf/Patent-Marking.pdf. SCILLC reserves the right to make changes without further notice to any products herein. SCILLC makes no warranty, representation or guarantee regarding the suitability of its products for any particular purpose, nor does SCILLC assume any liability arising out of the application or use of any product or circuit, and specifically disclaims any and all liability, including without limitation special, consequential or incidental damages. "Typical" parameters which may be provided in SCILLC data sheets and/or specifications can and do vary in different applications and actual performance may vary over time. All operating parameters, including "Typicals" must be validated for each customer application by customer's technical experts. SCILLC does not convey any license under its patent rights nor the rights of others. SCILLC products are not designed, intended, or authorized for use as components in systems intended for surgical implant into the body, or other applications intended to support or sustain life, or for any other application in which the failure of the SCILLC product could create a situation where personal injury or death may occur. Should Buyer purchase or use SCILLC products for any such unintended or unauthorized application, Buyer shall indemnify and hold SCILLC and its officers, employees, subsidiaries, affiliates, and distributors harmless against all claims, costs, damages, and expenses, and reasonable attorney fees arising out of, directly or indirectly, any claim of personal injury or death associated with such unintended or unauthorized use, even if such claim alleges that SCILLC was negligent regarding the design or manufacture of the part. SCILLC is an Equal Opportunity/Affirmative Action Employer. This literature is subject to all applicable copyright laws and is not for resale in any manner.