



SANYO Semiconductors

DATA SHEET

LV3327PV LV3327PGP

Bi-CMOS LSI

Electronic Volume IC

Overview

The LV3327PV/PGP is electronic volume LSI for the volume adjustment of the portable sound equipment usage.

Features

- The mixing function is installed, and it is suitable for PND (personal navigation device) as the usage. It is possible to output it by allocating one system in the audio guidance among four input systems, and mixing other signals from the speaker output with the audio guidance by the microcomputer control.
- Because the volume step resolution is 0.5dB step, the volume can be made to fine-tune.
- Two kinds of compact packages are prepared. (SSOP16/VCT16)
- The loudness function is installed.

Functions

- Input switching : 4 input systems (Independent control is possible.)
- Volume control : +10dB to -79.5dB(0.5dB steps)/-∞
- Loudness control :
Taps are output starting at the -32dB position of the ladder resistor and a loudness function implemented with external capacitor and resistor components.
- Output gain control : 0dB or +6dB select
- Mixing function
- Output switching :
2 outputs (Each Lch output, Rch output, and Lch/Rch mixing output can be selected).
- Each control is done by the serial data input. I²C

■ Any and all SANYO Semiconductor Co.,Ltd. products described or contained herein are, with regard to "standard application", intended for the use as general electronics equipment (home appliances, AV equipment, communication device, office equipment, industrial equipment etc.). The products mentioned herein shall not be intended for use for any "special application" (medical equipment whose purpose is to sustain life, aerospace instrument, nuclear control device, burning appliances, transportation machine, traffic signal system, safety equipment etc.) that shall require extremely high level of reliability and can directly threaten human lives in case of failure or malfunction of the product or may cause harm to human bodies, nor shall they grant any guarantee thereof. If you should intend to use our products for applications outside the standard applications of our customer who is considering such use and/or outside the scope of our intended standard applications, please consult with us prior to the intended use. If there is no consultation or inquiry before the intended use, our customer shall be solely responsible for the use.

■ Specifications of any and all SANYO Semiconductor Co.,Ltd. products described or contained herein stipulate the performance, characteristics, and functions of the described products in the independent state, and are not guarantees of the performance, characteristics, and functions of the described products as mounted in the customer's products or equipment. To verify symptoms and states that cannot be evaluated in an independent device, the customer should always evaluate and test devices mounted in the customer's products or equipment.

LV3327PV/PGP

Specifications

Absolute Maximum Ratings at $T_a = 25^\circ\text{C}$, $V_{SS} = 0\text{V}$

Parameter	Symbol	Conditions	Ratings	Unit
Maximum supply voltage	$V_{DD\text{ max}}$	V_{DD}	6	V
Maximum input voltage	$V_{IN\text{ max}}$	All input pins	$V_{SS}-0.3$ to V_{DD}	V
Operating temperature	T_{opr}		-40 to +85	$^\circ\text{C}$
Storage temperature	T_{stg}		-50 to +125	$^\circ\text{C}$

Allowable Operating Ratings at $T_a = 25^\circ\text{C}$, $V_{SS} = 0\text{V}$

Parameter	Symbol	Conditions	Ratings			Unit
			min	typ	max	
Supply voltage	V_{DD}	V_{DD}	3.0	5.0	5.5	V
High-level input voltage	V_{IH}	DATA, CLK	$0.7 V_{DD}$		V_{DD}	V
Low-level input voltage	V_{IL}	DATA, CLK	V_{SS}		$0.2 V_{DD}$	V
Input pulse width	$T_{\phi W}$	CLK	0.6			μsec
Setup time	T_{setup}	DATA, CLK	0.1			μsec
Hold time	T_{hold}	DATA, CLK			0.9	μsec
Operating frequency	f_{opg}	CLK			400	kHz

Electrical Characteristics at $T_a = 25^\circ\text{C}$, $V_{DD} = 5\text{V}$, $V_{SS} = 0\text{V}$

Parameter	Symbol	Conditions	Ratings			Unit
			min	typ	max	
A loss of insertion	ATT		-1.0		+1.0	dB
Input resistance	R_{in}	IN1/IN2/IN3/IN4		50		$\text{k}\Omega$
Volumn step setting error margin	ATerr	+10dB to -40dB	-1.0		+1.0	dB
Total harmonic distortion	THD	$V_{IN} = 1\text{V}_{rms}$, $f = 1\text{kHz}$		0.01		%
Maximum attenuation	$V_O\text{ min}$	$V_{IN} = 1\text{V}_{rms}$, $f = 1\text{kHz}$		80		dB
Output noise voltage	V_N	$R_{in}=1\text{k}\Omega$		5		μV_{rms}
Current drain	I_{DD}			5		mA
Input high-level current	I_{IH}	DATA, CLK, $V_{IN} = 5.0\text{V}$			10	μA
Input low-level current	I_{IL}	DATA, CLK, $V_{IN} = 0\text{V}$	-10			μA
Maximum input voltage	VCL	THD = 1% $R_L = 10\text{k}\Omega$ volumn setting : flat, $f_{IN} = 1\text{kHz}$	1.0			V_{rms}

Package Dimensions

unit : mm (typ)

3178B[LV3327PV]

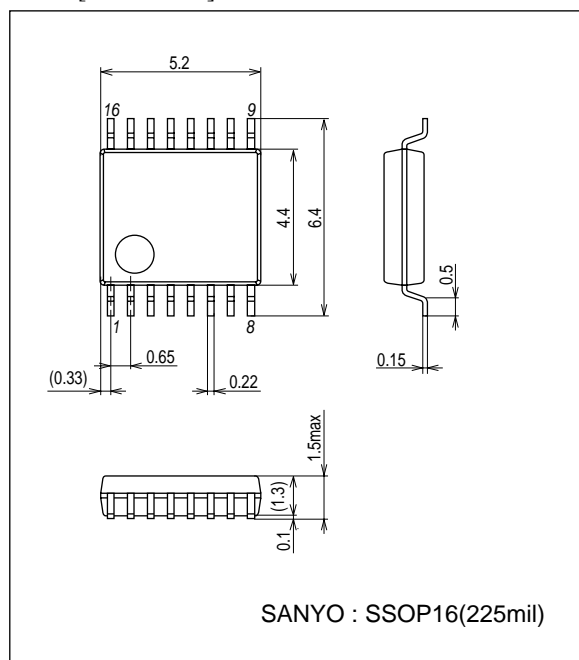

3318[LV3327PGP]

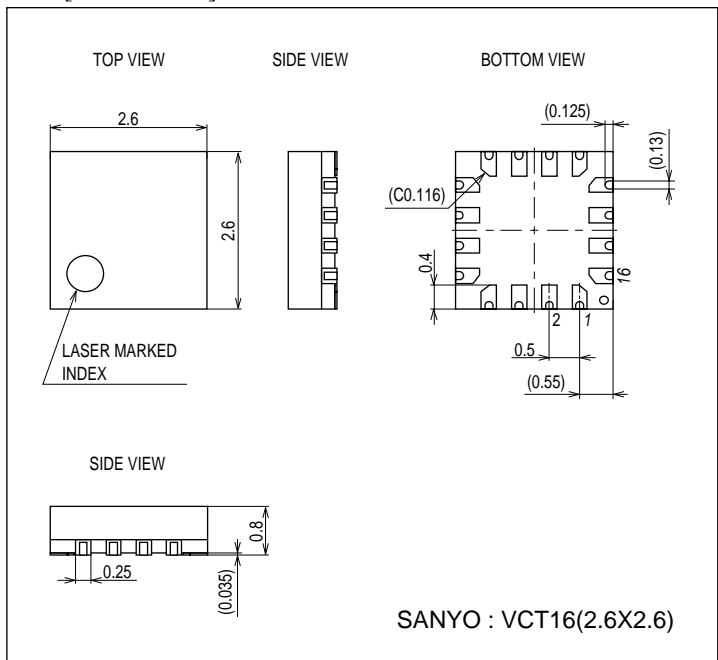

LV3327PV/PGP

Pin Assignment

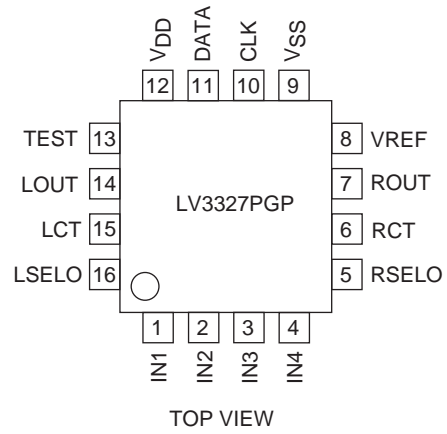
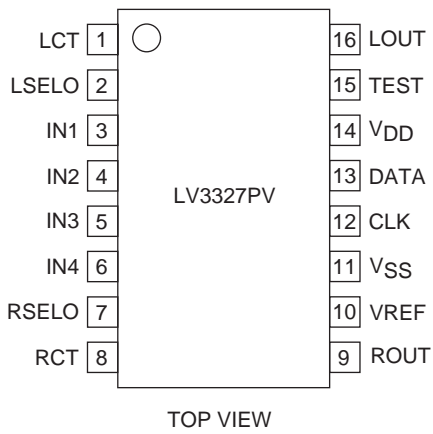

Block Diagram

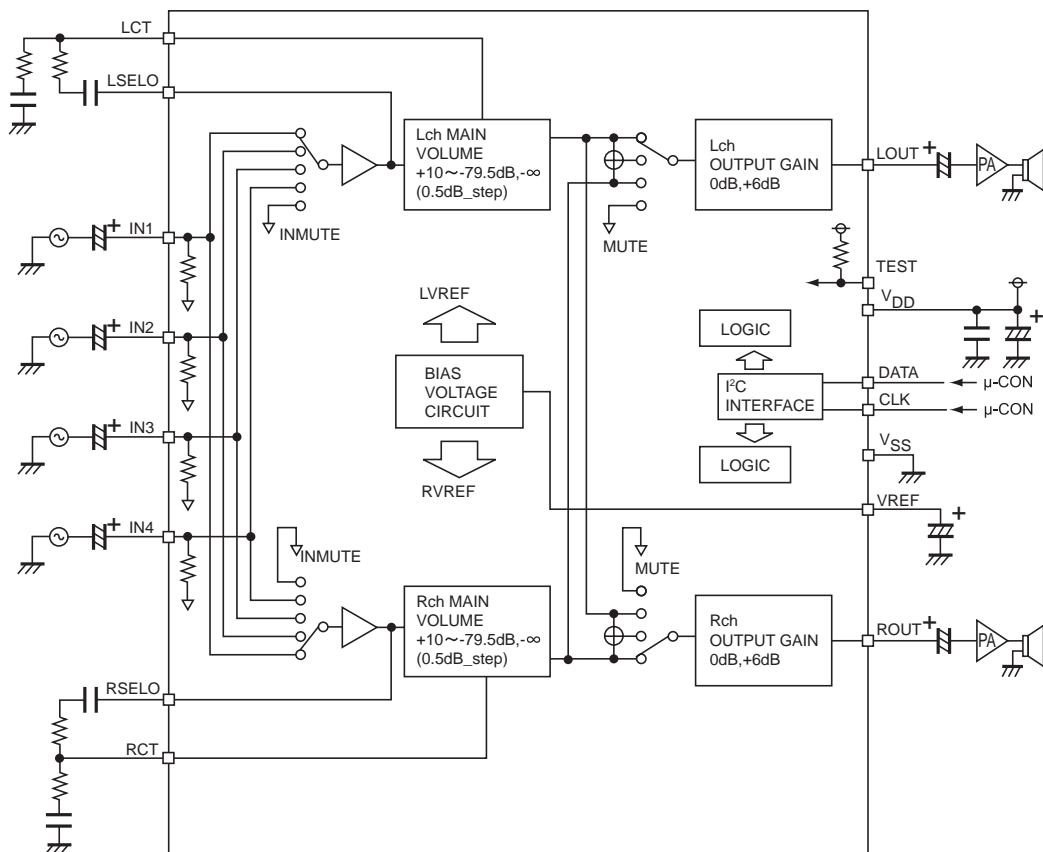

LV3327PV/PGP

Pin Functions

Pin	Pin No.		Function	Equivalent Circuit
	LV3327PV	LV3327PGP		
IN1 IN2 IN3 IN4	3 4 5 6	1 2 3 4	Input pins.	
LSELO RSELO	2 7	16 5	Input selector output pins	
LCT RCT	1 8	15 6	Tap pins for external loudness	
LOUT ROUT	16 9	14 7	Output pins.	
VREF	10	8	Connect a capacitor of a few tens of uF between VREF and AVSS (VSS) as a 0.5 × VDD voltage generator, current ripple countermeasure.	
CLK	12	10	Serial data clock input pin for control.	
DATA	13	11	Serial data input pin for control.	
TEST	15	13	TEST pin Normally this pin is OPEN.	
VDD	14	12	Power supply pin.	
VSS	11	9	Ground pin.	

LV3327PV/PGP

DATA format : I²C data specification

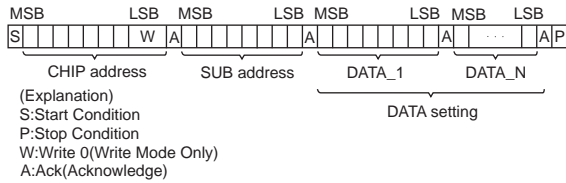

CHIP address

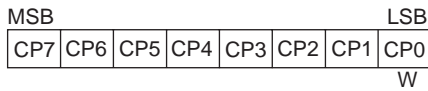

CP7	CP6	CP5	CP4	CP3	CP2	CP1	CP0
1	0	0	0	0	0	1	0

SUB address

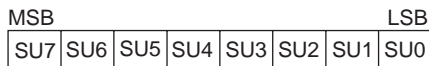

Block	SUB address								
	DATA	SU7	SU6	SU5	SU4	SU3	SU2	SU1	SU0
Input switching control (Lch)	DATA_1	1	0	0	0	0	0	0	0
Input switching control (Rch)	DATA_2	0	1	0	0	0	0	0	0
Volume control (Lch)	DATA_5	1	0	1	0	0	0	0	0
Volume control (Rch)	DATA_6	0	1	1	0	0	0	0	0
Loudness	DATA_26	0	1	0	1	1	0	0	0
TEST control	DATA_29	1	0	1	1	1	0	0	0
Output switching control / Output gain control (Lch)	DATA_30	0	1	1	1	1	0	0	0
Output switching control / Output gain control (Rch)	DATA_31	1	1	1	1	1	0	0	0

DATA

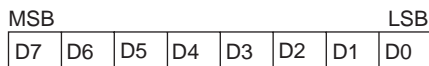

Input switching control (DATA_1, DATA_2)

D7	D6	D5	D4	D3	D2	D1	D0	
								DATA_1: Lch side DATA_2: Rch side
0	0	0	0	0	0	0	0	INMUTE
1	0	0	0	0	0	0	0	IN1 select
0	1	0	0	0	0	0	0	IN2 select
1	1	0	0	0	0	0	0	IN3 select
0	0	1	0	0	0	0	0	IN4 select

LV3327PV/PGP

Volume control :10.0dB to -18.0dB (DATA_5, DATA_6)

D7	D6	D5	D4	D3	D2	D1	D0	DATA_5:Lch side DATA_6:Rch side
0	0	1	1	0	1	1	1	10.0dB
1	0	1	1	0	1	1	1	9.5dB
0	1	1	1	0	1	1	1	9.0dB
1	1	1	1	0	1	1	1	8.5dB
0	0	0	0	1	1	1	1	8.0dB
1	0	0	0	1	1	1	1	7.5dB
0	1	0	0	1	1	1	1	7.0dB
1	1	0	0	1	1	1	1	6.5dB
0	0	1	0	1	1	1	1	6.0dB
1	0	1	0	1	1	1	1	5.5dB
0	1	1	0	1	1	1	1	5.0dB
1	1	1	0	1	1	1	1	4.5dB
0	0	0	1	1	1	1	1	4.0dB
1	0	0	1	1	1	1	1	3.5dB
0	1	0	1	1	1	1	1	3.0dB
1	1	0	1	1	1	1	1	2.5dB
0	0	1	1	1	1	1	1	2.0dB
1	0	1	1	1	1	1	1	1.5dB
0	1	1	1	1	1	1	1	1.0dB
1	1	1	1	1	1	1	1	0.5dB
0	0	0	0	0	0	0	0	0dB
1	0	0	0	0	0	0	0	-0.5dB
0	1	0	0	0	0	0	0	-1.0dB
1	1	0	0	0	0	0	0	-1.5dB
0	0	1	0	0	0	0	0	-2.0dB
1	0	1	0	0	0	0	0	-2.5dB
0	1	1	0	0	0	0	0	-3.0dB
1	1	1	0	0	0	0	0	-3.5dB
0	0	0	1	0	0	0	0	-4.0dB
1	0	0	1	0	0	0	0	-4.5dB
0	1	0	1	0	0	0	0	-5.0dB
1	1	0	1	0	0	0	0	-5.5dB
0	0	1	1	0	0	0	0	-6.0dB
1	0	1	1	0	0	0	0	-6.5dB
0	1	1	1	0	0	0	0	-7.0dB
1	1	1	1	0	0	0	0	-7.5dB
0	0	0	0	1	0	0	0	-8.0dB
1	0	0	0	1	0	0	0	-8.5dB
0	1	0	0	1	0	0	0	-9.0dB
1	1	0	0	1	0	0	0	-9.5dB
0	0	1	0	1	0	0	0	-10.0dB
1	0	1	0	1	0	0	0	-10.5dB
0	1	1	0	1	0	0	0	-11.0dB
1	1	1	0	1	0	0	0	-11.5dB
0	0	0	1	1	0	0	0	-12.0dB
1	0	0	1	1	0	0	0	-12.5dB
0	1	0	1	1	0	0	0	-13.0dB
1	1	0	1	1	0	0	0	-13.5dB
0	0	1	1	1	0	0	0	-14.0dB
1	0	1	1	1	0	0	0	-14.5dB
0	1	1	1	1	0	0	0	-15.0dB
1	1	1	1	1	0	0	0	-15.5dB
0	0	0	0	0	1	0	0	-16.0dB
1	0	0	0	0	1	0	0	-16.5dB
0	1	0	0	0	1	0	0	-17.0dB
1	1	0	0	0	1	0	0	-17.5dB
0	0	1	0	0	1	0	0	-18.0dB

LV3327PV/PGP

Volume control :-18.5dB to -43.5dB (DATA_5, DATA_6)

D7	D6	D5	D4	D3	D2	D1	D0	DATA_5:Lch side DATA_6:Rch side
1	0	1	0	0	1	0	0	-18.5dB
0	1	1	0	0	1	0	0	-19.0dB
1	1	1	0	0	1	0	0	-19.5dB
0	0	0	1	0	1	0	0	-20.0dB
1	0	0	1	0	1	0	0	-20.5dB
0	1	0	1	0	1	0	0	-21.0dB
1	1	0	1	0	1	0	0	-21.5dB
0	0	1	1	0	1	0	0	-22.0dB
1	0	1	1	0	1	0	0	-22.5dB
0	1	1	1	0	1	0	0	-23.0dB
1	1	1	1	0	1	0	0	-23.5dB
0	0	0	0	1	1	0	0	-24.0dB
1	0	0	0	1	1	0	0	-24.5dB
0	1	0	0	1	1	0	0	-25.0dB
1	1	0	0	1	1	0	0	-25.5dB
0	0	1	0	1	1	0	0	-26.0dB
1	0	1	0	1	1	0	0	-26.5dB
0	1	1	0	1	1	0	0	-27.0dB
1	1	1	0	1	1	0	0	-27.5dB
0	0	0	1	1	1	0	0	-28.0dB
1	0	0	1	1	1	0	0	-28.5dB
0	1	0	1	1	1	0	0	-29.0dB
1	1	0	1	1	1	0	0	-29.5dB
0	0	1	1	1	1	0	0	-30.0dB
1	0	1	1	1	1	0	0	-30.5dB
0	1	1	1	1	1	0	0	-31.0dB
1	1	1	1	1	1	0	0	-31.5dB
0	0	0	0	0	0	1	0	-32.0dB
1	0	0	0	0	0	1	0	-32.5dB
0	1	0	0	0	0	1	0	-33.0dB
1	1	0	0	0	0	1	0	-33.5dB
0	0	1	0	0	0	1	0	-34.0dB
1	0	1	0	0	0	1	0	-34.5dB
0	1	1	0	0	0	1	0	-35.0dB
1	1	1	0	0	0	1	0	-35.5dB
0	0	0	1	0	0	1	0	-36.0dB
1	0	0	1	0	0	1	0	-36.5dB
0	1	0	1	0	0	1	0	-37.0dB
1	1	0	1	0	0	1	0	-37.5dB
0	0	1	1	0	0	1	0	-38.0dB
1	0	1	1	0	0	1	0	-38.5dB
0	1	1	1	0	0	1	0	-39.0dB
1	1	1	1	0	0	1	0	-39.5dB
0	0	0	0	1	0	1	0	-40.0dB
1	0	0	0	1	0	1	0	-40.5dB
0	1	0	0	1	0	1	0	-41.0dB
1	1	0	0	1	0	1	0	-41.5dB
0	0	1	0	1	0	1	0	-42.0dB
1	0	1	0	1	0	1	0	-42.5dB
0	1	1	0	1	0	1	0	-43.0dB
1	1	1	0	1	0	1	0	-43.5dB

LV3327PV/PGP

Volume control :-44.0dB to -69.0dB (DATA_5, DATA_6)

D7	D6	D5	D4	D3	D2	D1	D0	DATA_5:Lch side DATA_6:Rch side
0	0	0	1	1	0	1	0	-44.0dB
1	0	0	1	1	0	1	0	-44.5dB
0	1	0	1	1	0	1	0	-45.0dB
1	1	0	1	1	0	1	0	-45.5dB
0	0	1	1	1	0	1	0	-46.0dB
1	0	1	1	1	0	1	0	-46.5dB
0	1	1	1	1	0	1	0	-47.0dB
1	1	1	1	1	0	1	0	-47.5dB
0	0	0	0	0	1	1	0	-48.0dB
1	0	0	0	0	1	1	0	-48.5dB
0	1	0	0	0	1	1	0	-49.0dB
1	1	0	0	0	1	1	0	-49.5dB
0	0	1	0	0	1	1	0	-50.0dB
1	0	1	0	0	1	1	0	-50.5dB
0	1	1	0	0	1	1	0	-51.0dB
1	1	1	0	0	1	1	0	-51.5dB
0	0	0	1	0	1	1	0	-52.0dB
1	0	0	1	0	1	1	0	-52.5dB
0	1	0	1	0	1	1	0	-53.0dB
1	1	0	1	0	1	1	0	-53.5dB
0	0	1	1	0	1	1	0	-54.0dB
1	0	1	1	0	1	1	0	-54.5dB
0	1	1	1	0	1	1	0	-55.0dB
1	1	1	1	0	1	1	0	-55.5dB
0	0	0	0	1	1	1	0	-56.0dB
1	0	0	0	1	1	1	0	-56.5dB
0	1	0	0	1	1	1	0	-57.0dB
1	1	0	0	1	1	1	0	-57.5dB
0	0	1	0	1	1	1	0	-58.0dB
1	0	1	0	1	1	1	0	-58.5dB
0	1	1	0	1	1	1	0	-59.0dB
1	1	1	0	1	1	1	0	-59.5dB
0	0	0	1	1	1	1	0	-60.0dB
1	0	0	1	1	1	1	0	-60.5dB
0	1	0	1	1	1	1	0	-61.0dB
1	1	0	1	1	1	1	0	-61.5dB
0	0	1	1	1	1	1	0	-62.0dB
1	0	1	1	1	1	1	0	-62.5dB
0	1	1	1	1	1	1	0	-63.0dB
1	1	1	1	1	1	1	0	-63.5dB
0	0	0	0	0	0	0	1	-64.0dB
1	0	0	0	0	0	0	1	-64.5dB
0	1	0	0	0	0	0	1	-65.0dB
1	1	0	0	0	0	0	1	-65.5dB
0	0	1	0	0	0	0	1	-66.0dB
1	0	1	0	0	0	0	1	-66.5dB
0	1	1	0	0	0	0	1	-67.0dB
1	1	1	0	0	0	0	1	-67.5dB
0	0	0	1	0	0	0	1	-68.0dB
1	0	0	1	0	0	0	1	-68.5dB
0	1	0	1	0	0	0	1	-69.0dB

LV3327PV/PGP

Volume control : -69.5dB to $-\infty$ (DATA_5, DATA_6)

D7	D6	D5	D4	D3	D2	D1	D0	DATA_5:Lch side DATA_6:Rch side
1	1	0	1	0	0	0	1	-69.5dB
0	0	1	1	0	0	0	1	-70.0dB
1	0	1	1	0	0	0	1	-70.5dB
0	1	1	1	0	0	0	1	-71.0dB
1	1	1	1	0	0	0	1	-71.5dB
0	0	0	0	1	0	0	1	-72.0dB
1	0	0	0	1	0	0	1	-72.5dB
0	1	0	0	1	0	0	1	-73.0dB
1	1	0	0	1	0	0	1	-73.5dB
0	0	1	0	1	0	0	1	-74.0dB
1	0	1	0	1	0	0	1	-74.5dB
0	1	1	0	1	0	0	1	-75.0dB
1	1	1	0	1	0	0	1	-75.5dB
0	0	0	1	1	0	0	1	-76.0dB
1	0	0	1	1	0	0	1	-76.5dB
0	1	0	1	1	0	0	1	-77.0dB
1	1	0	1	1	0	0	1	-77.5dB
0	0	1	1	1	0	0	1	-78.0dB
1	0	1	1	1	0	0	1	-78.5dB
0	1	1	1	1	0	0	1	-79.0dB
1	1	1	1	1	0	0	1	-79.5dB
0	0	0	0	0	1	0	1	$-\infty$

Loudness control (DATA_26)

D7	D6	D5	D4	D3	D2	D1	D0	DATA_26
0	0	0	0	0	0	0	0	Loudness: OFF
1	0	0	0	0	0	0	0	Loudness: ON

TEST control (DATA_29)

D7	D6	D5	D4	D3	D2	D1	D0	DATA_29
0	0	0	0	0	0	0	0	Setting usually for operation use

Output switching control / Output gain control (DATA_30, DATA_31)

D7	D6	D5	D4	D3	D2	D1	D0	DATA_30: Lch side DATA_31: Rch side
0	0	0	*	0	0	0	0	MUTE
1	0	0	*	0	0	0	0	Output selector: Lch side select
0	1	0	*	0	0	0	0	Output selector: Rch side select
1	1	0	*	0	0	0	0	Output selector: Lch/Rch mixing select
*	*	0	0	0	0	0	0	Output gain: 0dB setting
*	*	0	1	0	0	0	0	Output gain: 6dB setting

LV3327PV/PGP

Application Circuit Example

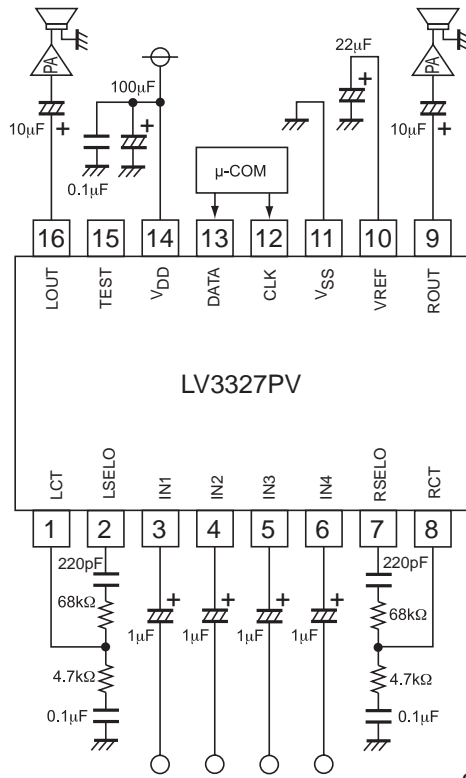

SSOP-16

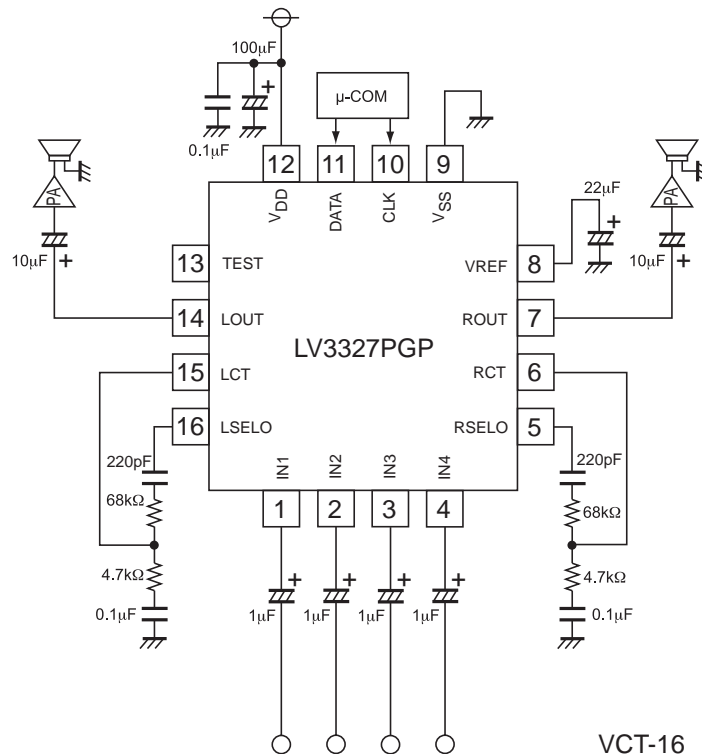

VCT-16

Usage Cautions

(1) Request to send the initial data at power ON

- Though the circuit initializing the IC inside at power ON is incorporated, be sure to send data to all sub-address as the initial data at power ON.
- At power ON, muting or other measures must be taken externally till the data is set.

Reference data

Parameter	Symbol	Conditions	Min	Typ	Max	Unit
VDD power rise time	Trise	0V → 2V power rise time	30	-	-	μsec
VDD voltage when power ON reset is canceled	Vpor		-	2	-	V

(2) Data is switched by standing up about the ACK clock of the data setting bit.

(3) The auto increment function is moved in the SUB address as follows.

...=>DATA_1=>DATA_2=>DATA_5=>DATA_6=>DATA_26=>DATA_29=>DATA_30=>DATA_31=>DATA_1=>...

(4) As for the mixing function, half the value in which the Lch volume output and the Rch volume output are added is output. $(Lch+Rch)/2$. Please set +6dB if necessary in the output steps.

- SANYO Semiconductor Co.,Ltd. assumes no responsibility for equipment failures that result from using products at values that exceed, even momentarily, rated values (such as maximum ratings, operating condition ranges, or other parameters) listed in products specifications of any and all SANYO Semiconductor Co.,Ltd. products described or contained herein.
- SANYO Semiconductor Co.,Ltd. strives to supply high-quality high-reliability products, however, any and all semiconductor products fail or malfunction with some probability. It is possible that these probabilistic failures or malfunction could give rise to accidents or events that could endanger human lives, trouble that could give rise to smoke or fire, or accidents that could cause damage to other property. When designing equipment, adopt safety measures so that these kinds of accidents or events cannot occur. Such measures include but are not limited to protective circuits and error prevention circuits for safe design, redundant design, and structural design.
- In the event that any or all SANYO Semiconductor Co.,Ltd. products described or contained herein are controlled under any of applicable local export control laws and regulations, such products may require the export license from the authorities concerned in accordance with the above law.
- No part of this publication may be reproduced or transmitted in any form or by any means, electronic or mechanical, including photocopying and recording, or any information storage or retrieval system, or otherwise, without the prior written consent of SANYO Semiconductor Co.,Ltd.
- Any and all information described or contained herein are subject to change without notice due to product/technology improvement, etc. When designing equipment, refer to the "Delivery Specification" for the SANYO Semiconductor Co.,Ltd. product that you intend to use.
- Information (including circuit diagrams and circuit parameters) herein is for example only; it is not guaranteed for volume production.
- Upon using the technical information or products described herein, neither warranty nor license shall be granted with regard to intellectual property rights or any other rights of SANYO Semiconductor Co.,Ltd. or any third party. SANYO Semiconductor Co.,Ltd. shall not be liable for any claim or suits with regard to a third party's intellectual property rights which has resulted from the use of the technical information and products mentioned above.

This catalog provides information as of November, 2010. Specifications and information herein are subject to change without notice.