

LC72131K LC72131KMA



ON Semiconductor®

CMOS IC

PLL Frequency Synthesizer

Overview

The LC72131K and LC72131KMA are PLL frequency synthesizers for use in tuners in radio/cassette players. They allow high-performance AM/FM tuners to be implemented easily.

Features

- High speed programmable dividers
 - FMIN: 10 to 160MHz pulse swallower (built-in divide-by-two prescaler)
 - AMIN: 2 to 40MHz pulse swallower
0.5 to 10MHz direct division
- IF counter
 - IFIN: 0.4 to 12MHz AM/FM IF counter
- Reference frequencies
 - Twelve selectable frequencies (4.5 or 7.2MHz crystal)
 - 100, 50, 25, 15, 12.5, 6.25, 3.125, 10, 9, 5, 3, 1kHz
- Phase comparator
 - Dead zone control
 - Unlock detection circuit
 - Deadlock clear circuit
 - Built-in MOS transistor for forming an active low-pass filter
- I/O ports
 - Dedicated output ports: 4 • Input or output ports: 2 • Support clock time base output
- Serial data I/O
 - Support CCB format communication with the system controller.

Continued on next page.

- CCB is ON Semiconductor® 's original format. All addresses are managed by ON Semiconductor® for this format.

- CCB is a registered trademark of Semiconductor Components Industries, LLC.

LC72131K, LC72131KMA

Continued from preceding page.

- Operating ranges
 - Supply voltage4.5 to 5.5V
 - Operating temperature -40 to +85°C
- Packages
 - DIP22S(300mil) / MFP20J(300mil)

Specifications

Absolute Maximum Ratings at $T_a = 25^\circ\text{C}$, $V_{SS} = 0\text{V}$

Parameter	Symbol	Pins	Conditions	Ratings	Unit
Supply voltage	V_{DD} max	V_{DD}		-0.3 to +7.0	V
Maximum input voltage	V_{IN1} max	CE, CL, DI, AIN		-0.3 to +7.0	V
	V_{IN2} max	XIN, FMIN, AMIN, IFIN		-0.3 to $V_{DD}+0.3$	V
	V_{IN3} max	$\overline{IO1}$, $\overline{IO2}$		-0.3 to +15	V
Maximum output voltage	V_{O1} max	DO		-0.3 to +7.0	V
	V_{O2} max	XOUT, PD		-0.3 to $V_{DD}+0.3$	V
	V_{O3} max	$\overline{BO1}$ to $\overline{BO4}$, $\overline{IO1}$, $\overline{IO2}$, AOUT		-0.3 to +15	V
Maximum output current	I_{O1} max	$\overline{BO1}$		0 to 3.0	mA
	I_{O2} max	DO, AOUT		0 to 6.0	mA
	I_{O3} max	$\overline{BO2}$ to $\overline{BO4}$, $\overline{IO1}$, $\overline{IO2}$		0 to 10	mA
Allowable power dissipation	P_d max		$T_a \leq 85^\circ\text{C}$ [LC72131K]	350	mW
			$T_a \leq 85^\circ\text{C}$ [LC72131KMA]	180	mW
Operating temperature	T_{opr}			-40 to +85	°C
Storage temperature	T_{stg}			-55 to +125	°C

Note 1: Power pins V_{DD} and V_{SS} : Insert a capacitor with a capacitance of 2,000pF or higher between these pins when using the IC.

Stresses exceeding Maximum Ratings may damage the device. Maximum Ratings are stress ratings only. Functional operation above the Recommended Operating Conditions is not implied. Extended exposure to stresses above the Recommended Operating Conditions may affect device reliability.

LC72131K, LC72131KMA

Allowable Operating Ranges at $T_a = -40^{\circ}\text{C}$ to $+85^{\circ}\text{C}$, $V_{SS} = 0\text{V}$

Parameter	Symbol	Pins	Conditions	Ratings			unit
				min	typ	max	
Supply voltage	V_{DD}	V_{DD}		4.5		5.5	V
Input high-level voltage	V_{IH1}	CE, CL, DI		$0.7V_{DD}$		6.5	V
	V_{IH2}	$\overline{IO1}$, $\overline{IO2}$		$0.7V_{DD}$		13	V
Input low-level voltage	V_{IL}	CE, CL, DI, $\overline{IO1}$, $\overline{IO2}$		0		$0.3V_{DD}$	V
Output voltage	V_{O1}	DO		0		6.5	V
	V_{O2}	$\overline{BO1}$ to $\overline{BO4}$, $\overline{IO1}$, $\overline{IO2}$, AOUT		0		13	V
Input frequency	f _{IN1}	XIN	V_{IN1}	1.0		8.0	MHz
	f _{IN2}	FMIN	V_{IN2}	10		160	MHz
	f _{IN3}	AMIN	V_{IN3}	2.0		40	MHz
	f _{IN4}	AMIN	V_{IN4}	0.5		10	MHz
	f _{IN5}	IFIN	V_{IN5}	0.4		12	MHz
Supported crystals	X'tal	XIN, XOUT	Note 1	4.0		8.0	MHz
Input amplitude	V_{IN1}	XIN	f _{IN1}	400		1500	mVrms
High-level clock pulse width t _{PH} CL [Figure 1][Figure 2] 160 ns Low-level clock pulse width	V_{IN2-1}	FMIN	f=10 to 130MHz	40		1500	mVrms
	V_{IN2-2}	FMIN	f=130 to 160MHz	70		1500	mVrms
	V_{IN3}	AMIN	f _{IN3}	40		1500	mVrms
	V_{IN4}	AMIN	f _{IN4}	40		1500	mVrms
	V_{IN5}	IFIN	f _{IN5} (IFS=1)	40		1500	mVrms
	V_{IN6}	IFIN	f _{IN5} (IFS=0)	70		1500	mVrms
Data setup time	t _{SU}	DI, CL	Note 2	0.75			μs
Data hold time	t _{HD}	DI, CL	Note 2	0.75			μs
Clock low-level time	t _{CL}	CL	Note 2	0.75			μs
Clock high-level time	t _{CH}	CL	Note 2	0.75			μs
CE wait time	t _{EL}	CE, CL	Note 2	0.75			μs
CE setup time	t _{ES}	CE, CL	Note 2	0.75			μs
CE hold time	t _{EH}	CE, CL	Note 2	0.75			μs
Data latch change time	t _{LC}		Note 2			0.75	μs
Data output time	t _{DC}	DO, CL	Differs depending on the value of the pull-up resistor. Note 2			0.35	μs
	t _{DH}	DO, CE					

Note 1: Recommended crystal oscillator CI values:

$CI \leq 120\Omega$ (For a 4.5MHz crystal)

$CI \leq 70\Omega$ (For a 7.2MHz crystal)

The characteristics of the oscillation circuit depends on the printed circuit board, circuit constants, and other factors. Therefore we recommend consulting with the manufacturer of the crystal for evaluation and reliability.

Note 2: Refer to "Serial Data Timing".

LC72131K, LC72131KMA

Electrical Characteristics in the Allowable Operating Ranges

Parameter	Symbol	Pins	Conditions	Ratings			unit	
				min	typ	max		
Built-in feedback resistance	Rf1	XIN			1.0		MΩ	
	Rf2	FMIN			500		kΩ	
	Rf3	AMIN			500		kΩ	
	Rf4	IFIN			250		kΩ	
Built-in pull-down resistor	Rpd1	FMIN			200		kΩ	
	Rpd2	AMIN			200		kΩ	
Hysteresis	VHYS	CE, CL, DI, $\overline{IO1}$, $\overline{IO2}$			0.1V _{DD}		V	
Output high-level voltage	V _{OH}	PD	I _O =1mA	V _{DD} -0.1			V	
Output low-level voltage	V _{OL1}	PD	I _O =1mA			1.0	V	
		$\overline{BO1}$	I _O =0.5mA			0.5	V	
	V _{OL2}		I _O =1mA			1.0	V	
		DO	I _O =1mA			0.2	V	
	V _{OL3}		I _O =5mA			1.0	V	
		V _{OL4}	$\overline{BO2}$ to $\overline{BO4}$, $\overline{IO1}$, $\overline{IO2}$	I _O =1mA			0.2	V
				I _O =5mA			1.0	V
		I _O =8mA			1.6	V		
V _{OL5}	AOUT	I _O =1mA AIN=1.3V			0.5	V		
Input high-level current	I _{IH1}	CE, CL, DI	V _I =6.5V			5.0	μA	
	I _{IH2}	$\overline{IO1}$, $\overline{IO2}$	V _I =13V			5.0	μA	
	I _{IH3}	XIN	V _I =V _{DD}	2.0		11	μA	
	I _{IH4}	FMIN, AMIN	V _I =V _{DD}	4.0		22	μA	
	I _{IH5}	IFIN	V _I =V _{DD}	8.0		44	μA	
	I _{IH6}	AIN	V _I =6.5V			200	nA	
Input low-level current	I _{IL1}	CE, CL, DI	V _I =0V			5.0	μA	
	I _{IL2}	$\overline{IO1}$, $\overline{IO2}$	V _I =0V			5.0	μA	
	I _{IL3}	XIN	V _I =0V	2.0		11	μA	
	I _{IL4}	FMIN, AMIN	V _I =0V	4.0		22	μA	
	I _{IL5}	IFIN	V _I =0V	8.0		44	μA	
	I _{IL6}	AIN	V _I =0V			200	nA	
Output off leakage current	IOFF1	$\overline{BO1}$ to $\overline{BO4}$, AOUT, $\overline{IO1}$, $\overline{IO2}$	V _O =13V			5.0	μA	
	IOFF2	DO	V _O =6.5V			5.0	μA	
High-level three-state off leakage current	IOFFH	PD	V _O =V _{DD}		0.01	200	nA	
Low-level three-state off leakage current	IOFFL	PD	V _O =0V		0.01	200	nA	
Input capacitance	CIN	FMIN			6		pF	
Current drain	I _{DD1}	V _{DD}	X'tal=7.2MHz f _{IN2} =130MHz V _{IN2} =40mVrms		5	10	mA	
	I _{DD2}	V _{DD}	PLL block stopped (PLL INHIBIT) X'tal oscillator operating (X'tal=7.2MHz)		0.5		mA	
	I _{DD3}	V _{DD}	PLL block stopped X'tal oscillator operating			10	μA	

LC72131K, LC72131KMA

Serial Data Timing

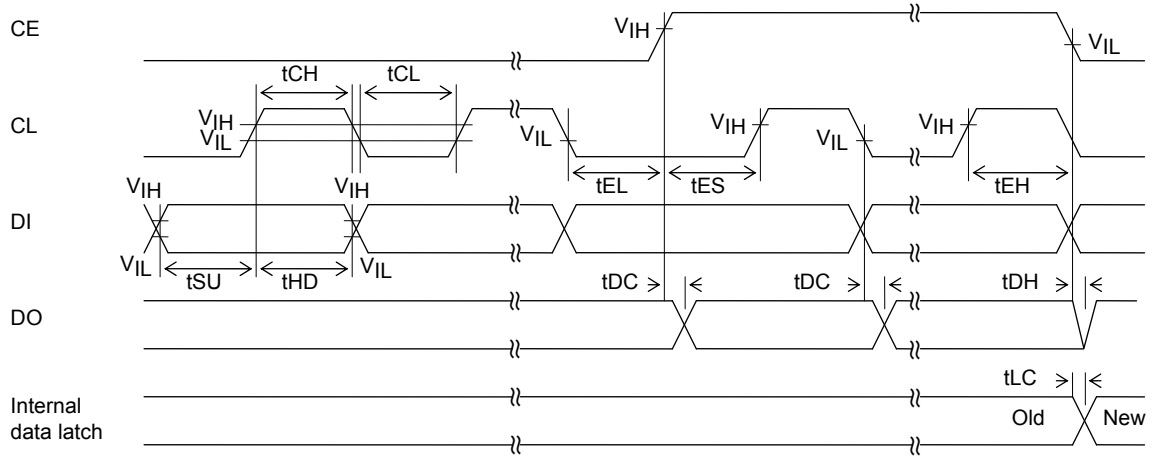

When stopped with CL low

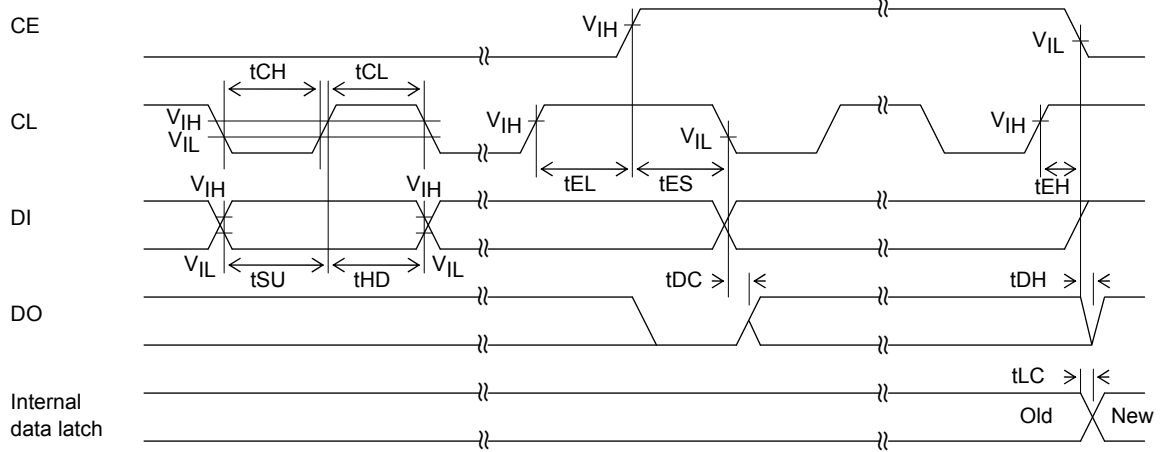

When stopped with CL high

Package Dimensions

unit : mm (typ)
3059A [LC72131K]

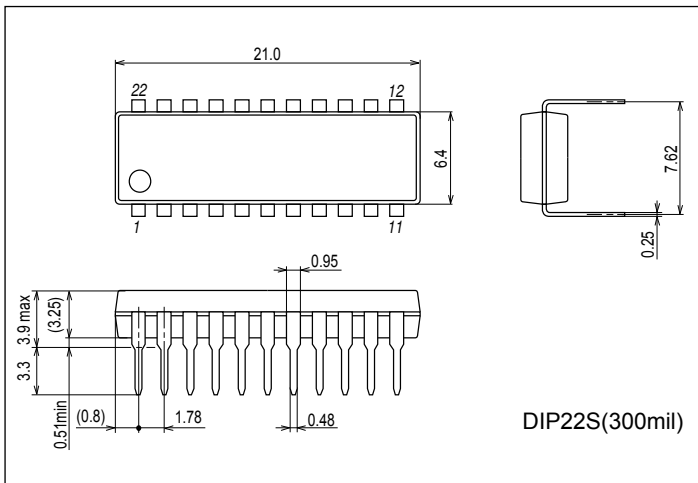

Package Dimensions

unit : mm (typ)
3445 [LC72131KMA]

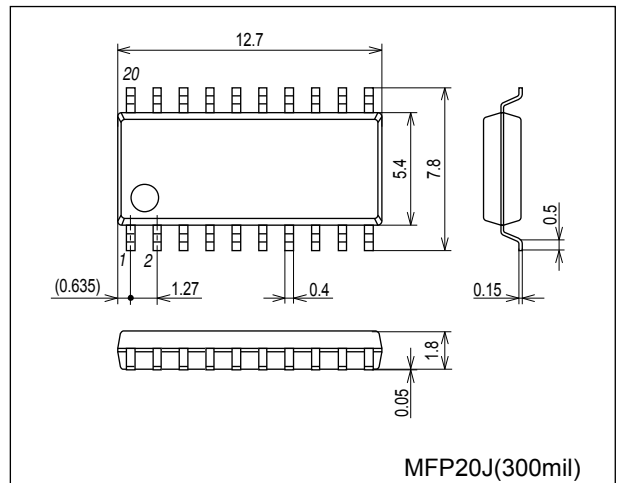

LC72131K, LC72131KMA

Pin Assignments

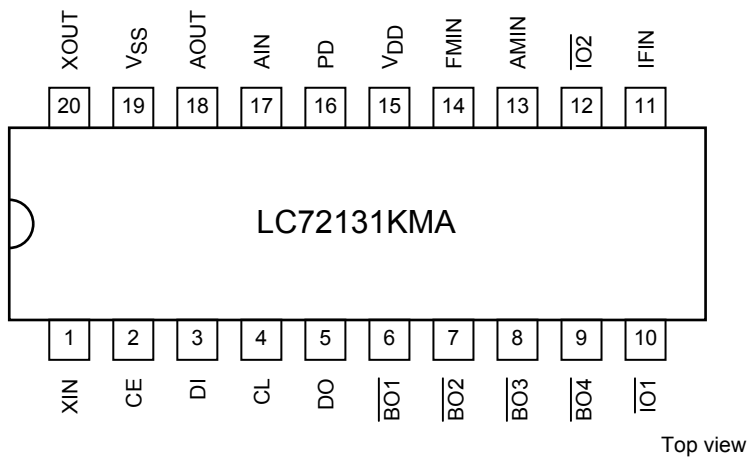
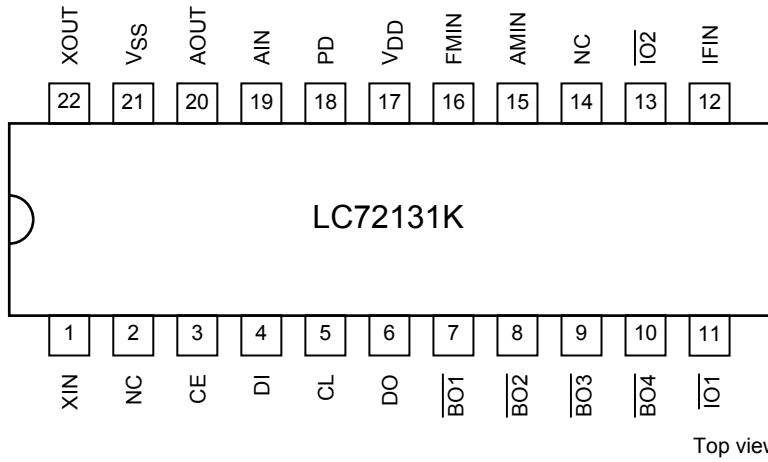

Block Diagram

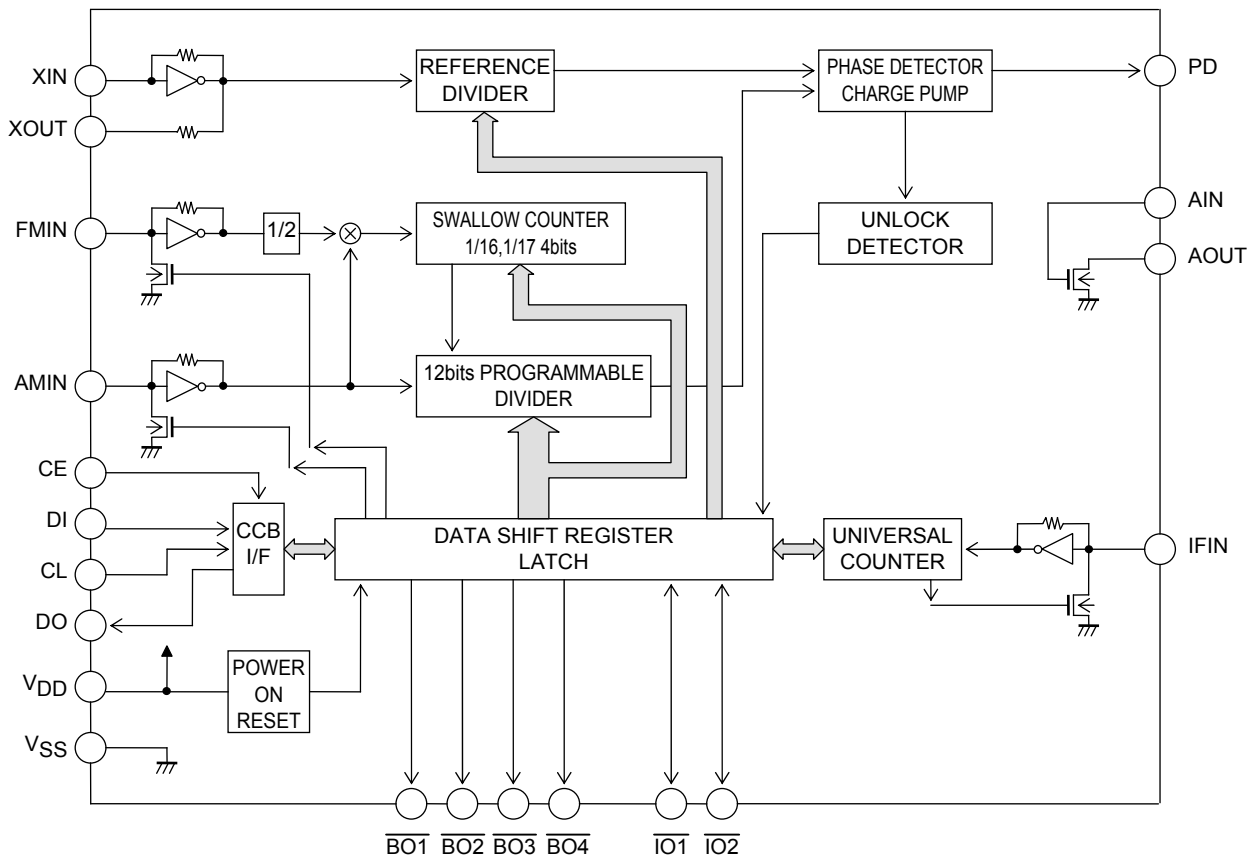

LC72131K, LC72131KMA

Pin Functions

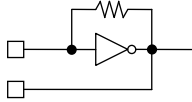
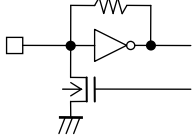
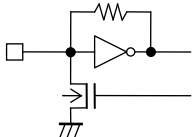
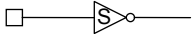
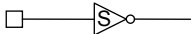
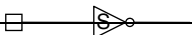
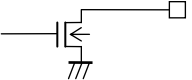
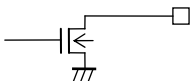
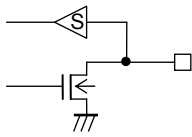
Symbol	Pin No.		Type	Functions	Circuit configuration
	LC72131K	LC72131KMA			
XIN XOUT	1 22	1 20	X'tal OSC	Crystal resonator connection (4.5MHz/7.2MHz)	
FMIN	16	14	Local oscillator signal input	FMIN is selected when the serial data input DVS bit is set to 1. The input frequency range is from 10 to 160MHz. The input signal passes through the internal divide-by-two prescaler and is input to the swallow counter. The divisor can be in the range 272 to 65535. However, since the signal has passed through the divide-by-two prescaler, the actual divisor is twice the set value.	
AMIN	15	13	Local oscillator signal input	AMIN is selected when the serial data input DVS bit is set to 0. When the serial data input SNS bit is set to 1: <ul style="list-style-type: none"> The input frequency range is 2 to 40MHz. The signal is directly input to the swallow counter. The divisor can be in the range 272 to 65535, and the divisor used will be the value set. When the serial data input SNS bit is set to 0: <ul style="list-style-type: none"> The input frequency range is 0.5 to 10MHz. The signal is directly input to a 12-bit programmable divider. The divisor can be in the range 4 to 4095, and the divisor used will be the value set. 	
CE	3	2	Chip enable	Set this pin high when inputting (DI) or outputting (DO) serial data.	
DI	4	3	Input data	Inputs serial data transferred from the controller to the LC72131K/KMA.	
CL	5	4	Clock	Used as the synchronization clock when inputting (DI) or outputting (DO) serial data.	
DO	6	5	Output data	Outputs serial data transferred from the LC72131K/KMA to the controller. The content of the output data is determined by the serial data DOC0 to DOC2.	
VDD	17	15	Power supply	The LC72131K/KMA power supply pin (VDD=4.5 to 5.5V) The power on reset circuit operates when power is first applied.	-
VSS	21	19	Ground	The LC72131K/KMA ground	-
$\overline{BO1}$ $\overline{BO2}$ $\overline{BO3}$ $\overline{BO4}$	7 8 9 10	6 7 8 9	Output port	Dedicated output pins The output states are determined by $\overline{BO1}$ to $\overline{BO4}$ bits in the serial data. Data: 0=open, 1=low A time base signal (8Hz) can be output from the $\overline{BO1}$ pin. (When the serial data TBC bit is set to 1.) Care is required when using the $\overline{BO1}$ pin, since it has a higher on impedance than the other output ports (pins $\overline{BO2}$ to $\overline{BO4}$).	
$\overline{IO1}$ $\overline{IO2}$	11 13	10 12	I/O port	I/O dual-use pins The direction (input or output) is determined by bits IOC1 and IOC2 in the serial data. Data: 0=input port, 1=output port When specified for use as input ports: The state of the input pin is transmitted to the controller over the DO pin. Input state: low=0 data value high=1 data value When specified for use as output ports: The output states are determined by the IO1 and IO2 bits in the serial data. Data: 0=open, 1=low These pins function as input pins following a power on reset.	

Continued on next page.

LC72131K, LC72131KMA

Control Data Functions

No.	Control block/data	Functions	Related data																																																																																					
(1)	Programmable divider data P0 to P15 DVS, SNS	Data that sets the divisor of the programmable divider. A binary value in which P15 is the MSB. The LSB changes depending on DVS and SNS. (*: don't care) <table border="1" style="width: 100%; border-collapse: collapse; margin-bottom: 5px;"> <thead> <tr> <th>DVS</th> <th>SNS</th> <th>LSB</th> <th>Divisor setting (N)</th> <th>Actual divisor</th> </tr> </thead> <tbody> <tr> <td>1</td> <td>*</td> <td>P0</td> <td>272 to 65535</td> <td>Twice the value of the setting</td> </tr> <tr> <td>0</td> <td>1</td> <td>P0</td> <td>272 to 65535</td> <td>The value of the setting</td> </tr> <tr> <td>0</td> <td>0</td> <td>P4</td> <td>4 to 4095</td> <td>The value of the setting</td> </tr> </tbody> </table> Note: P0 to P3 are ignored when P4 is the LSB. Selects the signal input pin (AMIN or FMIN) for the programmable divider, switches the input frequency range. (*: don't care) <table border="1" style="width: 100%; border-collapse: collapse; margin-bottom: 5px;"> <thead> <tr> <th>DVS</th> <th>SNS</th> <th>Input pin</th> <th>Input frequency range</th> </tr> </thead> <tbody> <tr> <td>1</td> <td>*</td> <td>FMIN</td> <td>10 to 160MHz</td> </tr> <tr> <td>0</td> <td>1</td> <td>AMIN</td> <td>2 to 40MHz</td> </tr> <tr> <td>0</td> <td>0</td> <td>AMIN</td> <td>0.5 to 10MHz</td> </tr> </tbody> </table> Note: See the "Programmable Divider Structure" item for more information.	DVS	SNS	LSB	Divisor setting (N)	Actual divisor	1	*	P0	272 to 65535	Twice the value of the setting	0	1	P0	272 to 65535	The value of the setting	0	0	P4	4 to 4095	The value of the setting	DVS	SNS	Input pin	Input frequency range	1	*	FMIN	10 to 160MHz	0	1	AMIN	2 to 40MHz	0	0	AMIN	0.5 to 10MHz																																																		
DVS	SNS	LSB	Divisor setting (N)	Actual divisor																																																																																				
1	*	P0	272 to 65535	Twice the value of the setting																																																																																				
0	1	P0	272 to 65535	The value of the setting																																																																																				
0	0	P4	4 to 4095	The value of the setting																																																																																				
DVS	SNS	Input pin	Input frequency range																																																																																					
1	*	FMIN	10 to 160MHz																																																																																					
0	1	AMIN	2 to 40MHz																																																																																					
0	0	AMIN	0.5 to 10MHz																																																																																					
(2)	Reference divider data R0 to R3 XS	Reference frequency (fref) selection data. <table border="1" style="width: 100%; border-collapse: collapse; margin-bottom: 5px;"> <thead> <tr> <th>R3</th> <th>R2</th> <th>R1</th> <th>R0</th> <th>Reference frequency</th> </tr> </thead> <tbody> <tr><td>0</td><td>0</td><td>0</td><td>0</td><td>100kHz</td></tr> <tr><td>0</td><td>0</td><td>0</td><td>1</td><td>50</td></tr> <tr><td>0</td><td>0</td><td>1</td><td>0</td><td>25</td></tr> <tr><td>0</td><td>0</td><td>1</td><td>1</td><td>25</td></tr> <tr><td>0</td><td>1</td><td>0</td><td>0</td><td>12.5</td></tr> <tr><td>0</td><td>1</td><td>0</td><td>1</td><td>6.25</td></tr> <tr><td>0</td><td>1</td><td>1</td><td>0</td><td>3.125</td></tr> <tr><td>0</td><td>1</td><td>1</td><td>1</td><td>3.125</td></tr> <tr><td>1</td><td>0</td><td>0</td><td>0</td><td>10</td></tr> <tr><td>1</td><td>0</td><td>0</td><td>1</td><td>9</td></tr> <tr><td>1</td><td>0</td><td>1</td><td>0</td><td>5</td></tr> <tr><td>1</td><td>0</td><td>1</td><td>1</td><td>1</td></tr> <tr><td>1</td><td>1</td><td>0</td><td>0</td><td>3</td></tr> <tr><td>1</td><td>1</td><td>0</td><td>1</td><td>15</td></tr> <tr><td>1</td><td>1</td><td>1</td><td>0</td><td>* PLL INHIBIT + X'tal OSC STOP</td></tr> <tr><td>1</td><td>1</td><td>1</td><td>1</td><td>* PLL INHIBIT</td></tr> </tbody> </table> Note *: PLL INHIBIT The programmable divider block and the IF counter block are stopped, the FMIN, AMIN, and IFIN pins are set to the pull-down state (ground), and the charge pump goes to the high impedance state. Crystal resonator selection XS=0: 4.5MHz XS=1: 7.2MHz The 7.2MHz frequency is selected after the power-on reset.	R3	R2	R1	R0	Reference frequency	0	0	0	0	100kHz	0	0	0	1	50	0	0	1	0	25	0	0	1	1	25	0	1	0	0	12.5	0	1	0	1	6.25	0	1	1	0	3.125	0	1	1	1	3.125	1	0	0	0	10	1	0	0	1	9	1	0	1	0	5	1	0	1	1	1	1	1	0	0	3	1	1	0	1	15	1	1	1	0	* PLL INHIBIT + X'tal OSC STOP	1	1	1	1	* PLL INHIBIT	
R3	R2	R1	R0	Reference frequency																																																																																				
0	0	0	0	100kHz																																																																																				
0	0	0	1	50																																																																																				
0	0	1	0	25																																																																																				
0	0	1	1	25																																																																																				
0	1	0	0	12.5																																																																																				
0	1	0	1	6.25																																																																																				
0	1	1	0	3.125																																																																																				
0	1	1	1	3.125																																																																																				
1	0	0	0	10																																																																																				
1	0	0	1	9																																																																																				
1	0	1	0	5																																																																																				
1	0	1	1	1																																																																																				
1	1	0	0	3																																																																																				
1	1	0	1	15																																																																																				
1	1	1	0	* PLL INHIBIT + X'tal OSC STOP																																																																																				
1	1	1	1	* PLL INHIBIT																																																																																				
(3)	IF counter control data CTE GT0, GT1	IF counter measurement start data CTE=1: Counter start =0: Counter reset Determines the IF counter measurement period. <table border="1" style="width: 100%; border-collapse: collapse; margin-bottom: 5px;"> <thead> <tr> <th>GT1</th> <th>GT0</th> <th>Measurement time (ms)</th> <th>Wait time (ms)</th> </tr> </thead> <tbody> <tr> <td>0</td> <td>0</td> <td>4</td> <td>3 to 4</td> </tr> <tr> <td>0</td> <td>1</td> <td>8</td> <td>3 to 4</td> </tr> <tr> <td>1</td> <td>0</td> <td>32</td> <td>7 to 8</td> </tr> <tr> <td>1</td> <td>1</td> <td>64</td> <td>7 to 8</td> </tr> </tbody> </table> Note: See the "IF Counter Structure" item for more information.	GT1	GT0	Measurement time (ms)	Wait time (ms)	0	0	4	3 to 4	0	1	8	3 to 4	1	0	32	7 to 8	1	1	64	7 to 8	IFS																																																																	
GT1	GT0	Measurement time (ms)	Wait time (ms)																																																																																					
0	0	4	3 to 4																																																																																					
0	1	8	3 to 4																																																																																					
1	0	32	7 to 8																																																																																					
1	1	64	7 to 8																																																																																					

Continued on next page.

LC72131K, LC72131KMA

Continued from preceding page.

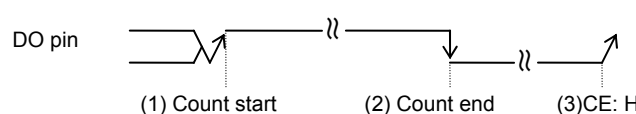
No.	Control block/data	Functions	Related data																																				
(4)	I/O port specification data IOC1, IOC2	Specifies the I/O direction for the bidirectional pins $\overline{IO1}$ and $\overline{IO2}$. Data: 0=input mode, 1=output mode																																					
(5)	Output port data BO1 to BO4 IO1, IO2	Data that determines the output from the $\overline{BO1}$ to $\overline{BO4}$, $\overline{IO1}$ and $\overline{IO2}$ output ports Data: 0=open, 1=low The data=0 (open) state is selected after the power-on reset.	IOC1 IOC2																																				
(6)	DO pin control data DOC0 DOC1 DOC2	<p>Data that determines the DO pin output</p> <table border="1" style="width: 100%; border-collapse: collapse; margin-bottom: 10px;"> <thead> <tr> <th>DOC2</th> <th>DOC1</th> <th>DOC0</th> <th>Do pin state</th> </tr> </thead> <tbody> <tr> <td>0</td> <td>0</td> <td>0</td> <td>Open</td> </tr> <tr> <td>0</td> <td>0</td> <td>1</td> <td>Low when the unlock state is detected</td> </tr> <tr> <td>0</td> <td>1</td> <td>0</td> <td>end-UC *1</td> </tr> <tr> <td>0</td> <td>1</td> <td>1</td> <td>Open</td> </tr> <tr> <td>1</td> <td>0</td> <td>0</td> <td>Open</td> </tr> <tr> <td>1</td> <td>0</td> <td>1</td> <td>The $\overline{IO1}$ pin state *2</td> </tr> <tr> <td>1</td> <td>1</td> <td>0</td> <td>The $\overline{IO2}$ pin state *2</td> </tr> <tr> <td>1</td> <td>1</td> <td>1</td> <td>Open</td> </tr> </tbody> </table> <p>The open state is selected after the power-on reset. Note: 1. end-UC: Check for IF counter measurement completion</p> <div style="margin-bottom: 10px;"> <p>DO pin </p> <p style="text-align: center;">(1) Count start (2) Count end (3)CE: High</p> </div> <p>(1) When end-UC is set and the IF counter is started (i.e., when CTE is changed from zero to one), the DO pin automatically goes to the open state. (2) When the IF counter measurement completes, the DO pin goes low to indicate the measurement completion state. (3) Depending on serial data I/O (CE: high) the DO pin goes to the open state.</p> <p>Note: 2. Goes to the open state if the I/O pin is specified to be an output port. Caution: The state of the DO pin during a data input period (an IN1 or IN2 mode period with CE high) will be open, regardless of the state of the DO control data (DOC0 to DOC2). Also, the DO pin during a data output period (an OUT mode period with CE high) will output the contents of the internal DO serial data in synchronization with the CL pin signal, regardless of the state of the DO control data (DOC0 to DOC2).</p>	DOC2	DOC1	DOC0	Do pin state	0	0	0	Open	0	0	1	Low when the unlock state is detected	0	1	0	end-UC *1	0	1	1	Open	1	0	0	Open	1	0	1	The $\overline{IO1}$ pin state *2	1	1	0	The $\overline{IO2}$ pin state *2	1	1	1	Open	UL0, UL1 CTE IOC1 IOC2
DOC2	DOC1	DOC0	Do pin state																																				
0	0	0	Open																																				
0	0	1	Low when the unlock state is detected																																				
0	1	0	end-UC *1																																				
0	1	1	Open																																				
1	0	0	Open																																				
1	0	1	The $\overline{IO1}$ pin state *2																																				
1	1	0	The $\overline{IO2}$ pin state *2																																				
1	1	1	Open																																				
(7)	Unlock detection data UL0, UL1	<p>Selects the phase error (ϕE) detection width for checking PLL lock. A phase error in excess of the specified detection width is seen as an unlocked state.</p> <table border="1" style="width: 100%; border-collapse: collapse; margin-bottom: 10px;"> <thead> <tr> <th>UL1</th> <th>UL0</th> <th>ϕE detection width</th> <th>Detector output</th> </tr> </thead> <tbody> <tr> <td>0</td> <td>0</td> <td>stopped</td> <td>Open</td> </tr> <tr> <td>0</td> <td>1</td> <td>0</td> <td>ϕE is output directly</td> </tr> <tr> <td>1</td> <td>0</td> <td>$\pm 0.55\mu s$</td> <td>ϕE is extended by 1 to 2ms</td> </tr> <tr> <td>1</td> <td>1</td> <td>± 1.11</td> <td>↑</td> </tr> </tbody> </table> <p>Note: In the unlocked state the DO pin goes low and the UL bit in the serial data becomes zero.</p>	UL1	UL0	ϕE detection width	Detector output	0	0	stopped	Open	0	1	0	ϕE is output directly	1	0	$\pm 0.55\mu s$	ϕE is extended by 1 to 2ms	1	1	± 1.11	↑	DOC0 DOC1 DOC2																
UL1	UL0	ϕE detection width	Detector output																																				
0	0	stopped	Open																																				
0	1	0	ϕE is output directly																																				
1	0	$\pm 0.55\mu s$	ϕE is extended by 1 to 2ms																																				
1	1	± 1.11	↑																																				

Continued on next page.

LC72131K, LC72131KMA

Continued from preceding page.

No.	Control block/data	Functions	Related data															
(8)	Phase comparator control data DZ0, DZ1	<ul style="list-style-type: none"> Controls the phase comparator dead zone. <table border="1" style="margin-left: 20px; border-collapse: collapse;"> <thead> <tr> <th>DZ1</th> <th>DZ0</th> <th>Dead zone mode</th> </tr> </thead> <tbody> <tr> <td>0</td> <td>0</td> <td>DZA</td> </tr> <tr> <td>0</td> <td>1</td> <td>DZB</td> </tr> <tr> <td>1</td> <td>0</td> <td>DZC</td> </tr> <tr> <td>1</td> <td>1</td> <td>DZD</td> </tr> </tbody> </table> <p>Dead zone width: DZA<DZB<DZC<DZD</p>	DZ1	DZ0	Dead zone mode	0	0	DZA	0	1	DZB	1	0	DZC	1	1	DZD	
DZ1	DZ0	Dead zone mode																
0	0	DZA																
0	1	DZB																
1	0	DZC																
1	1	DZD																
(9)	Clock time base TBC	Setting TBC to one causes an 8Hz, 40% duty clock time base signal to be output from the $\overline{BO1}$ pin. (BO1 data is invalid in this mode.)	BO1															
(10)	Charge pump control data DLC	<p>Forcibly controls the charge pump output.</p> <table border="1" style="margin-left: 20px; border-collapse: collapse;"> <thead> <tr> <th>DLC</th> <th>Charge pump output</th> </tr> </thead> <tbody> <tr> <td>0</td> <td>Normal operation</td> </tr> <tr> <td>1</td> <td>Forced low</td> </tr> </tbody> </table> <p>Note: If deadlock occurs due to the VCO control voltage (Vtune) going to zero and the VCO oscillator stopping, deadlock can be cleared by forcing the charge pump output to low and setting Vtune to V_{CC}. (This is the deadlock clearing circuit.)</p>	DLC	Charge pump output	0	Normal operation	1	Forced low										
DLC	Charge pump output																	
0	Normal operation																	
1	Forced low																	
(11)	IF counter control data IFS	<p>This data must be set 1 in normal mode.</p> <p>IFS Though if this value is set to zero, the system enters input sensitivity degradation mode, and the sensitivity is reduced to 10 to 30mVrms.</p> <p>* See the "IF Counter Operation" item for details.</p>																
(12)	LSI test data TEST0 to 2	<p>LSI test data</p> <p>TEST0 TEST1 TEST2</p> <p style="margin-left: 40px;">} These values must all be set to 0.</p> <p>These test data are set to 0 automatically after the power-on reset.</p>																
(13)	DNC	Don't care. This data must be set to 0.																

DO Control Data (Serial Data Output) Structure

[3] OUT Mode

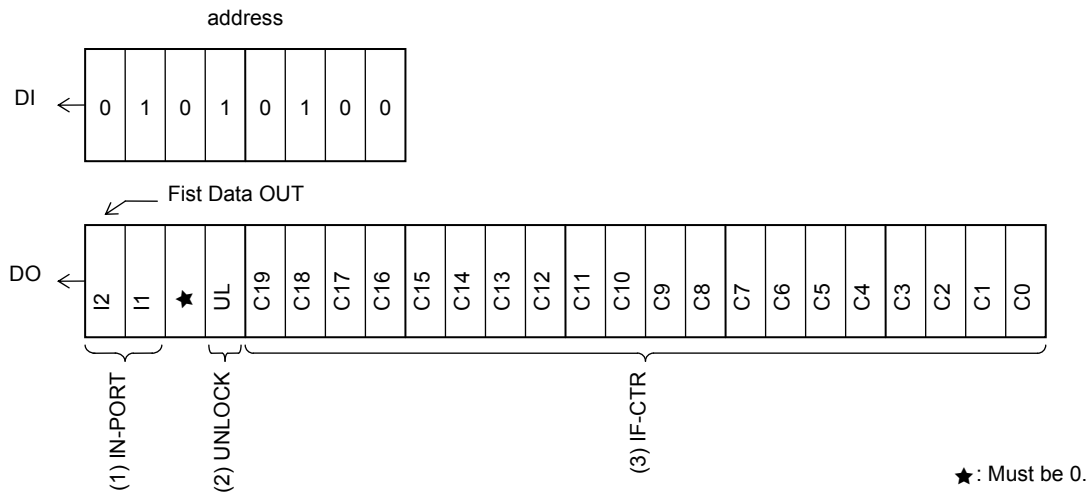

LC72131K, LC72131KMA

Control Data Functions

No.	Control block/data	Functions	Related data
(1)	I/O port data I2, I1	Latched from the pin states of the $\overline{IO1}$ and $\overline{IO2}$ I/O ports. These values follow the pin states regardless of the input or output setting. $I1 \leftarrow \overline{IO1}$ pin state High: 1 $I2 \leftarrow \overline{IO2}$ pin state Low: 0	IOC1 IOC2
(2)	PLL unlock data UL	Latched from the state of the unlock detection circuit. UL \leftarrow 0: Unlocked UL \leftarrow 1: Locked or detection stopped mode	UL0 UL1
(3)	IF counter binary counter C19 to C0	Latched from the value of the IF counter (20-bit binary counter). C19 \leftarrow MSB of the binary counter C0 \leftarrow LSB of the binary counter	CTE GT0 GT1

Serial Data I/O Methods

The LC72131K/KMA inputs and outputs data using Our CCB (computer control bus) audio LSI serial bus format. This LSI adopts an 8-bit address format CCB.

	I/O mode	Address								Function
		B0	B1	B2	B3	A0	A1	A2	A3	
[1]	IN1 (82)	0	0	0	1	0	1	0	0	<ul style="list-style-type: none"> Control data input mode (serial data input) 24 data bits are input. See the "DI Control Data (serial data input) Structure" item for details on the meaning of the input data.
[2]	IN2 (92)	1	0	0	1	0	1	0	0	<ul style="list-style-type: none"> Control data input mode (serial data input) 24 data bits are input. See the "DI Control Data (serial data input) Structure" item for details on the meaning of the input data.
[3]	OUT (A2)	0	1	0	1	0	1	0	0	<ul style="list-style-type: none"> Data output mode (serial data output) The number of bits output is equal to the number of clock cycles. See the "DO Control Data (serial data output) Structure" item for details on the meaning of the output data.

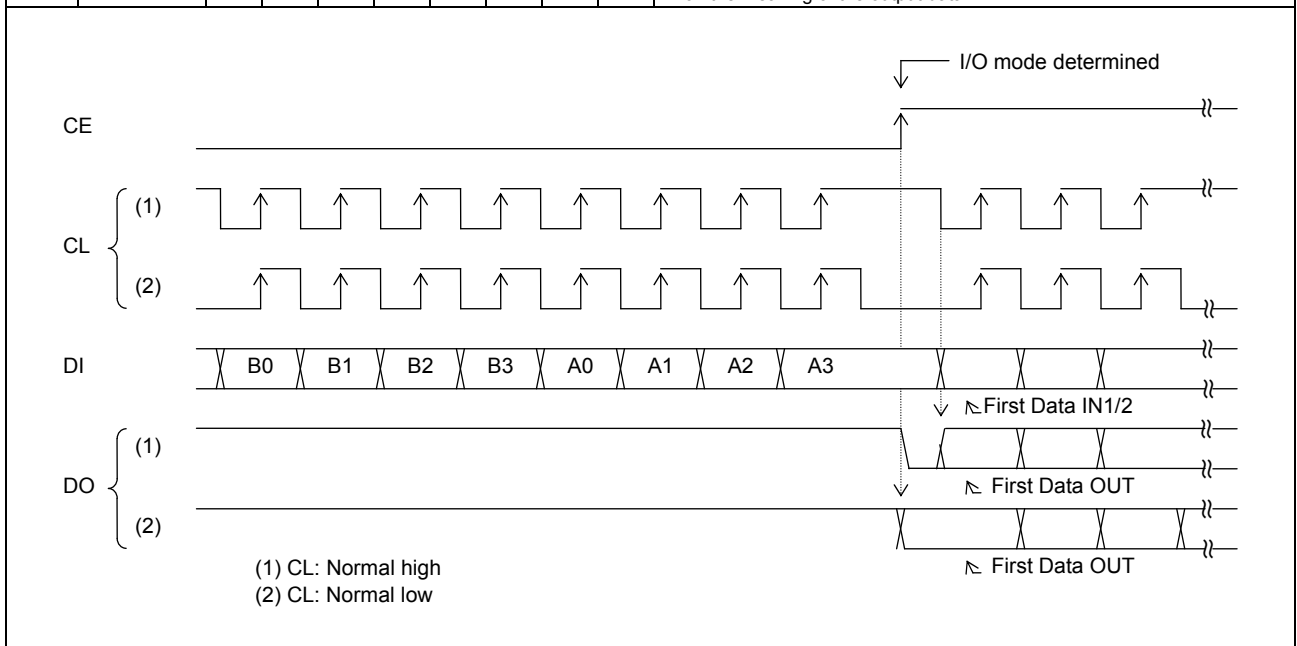

LC72131K, LC72131KMA

1. Serial Data Input (IN1/IN2) t_{SU} , t_{HD} , t_{ES} , $t_{EH} \geq 0.75\mu s$ $t_{LC} < 0.75\mu s$

(1) CL: Normal high

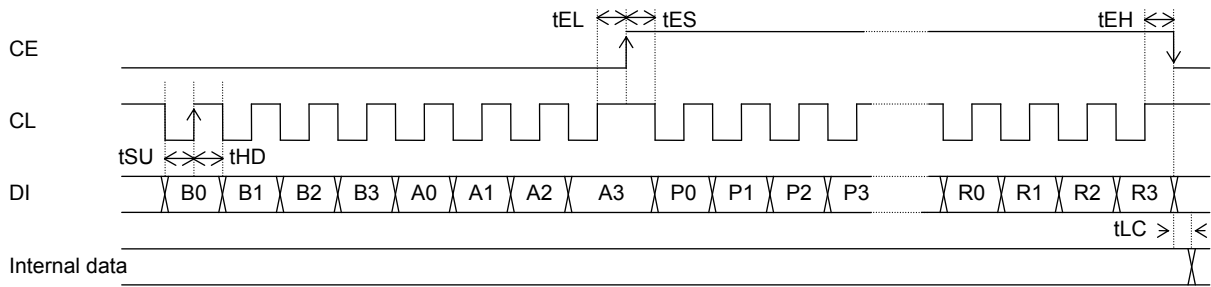

(2) CL: Normal low

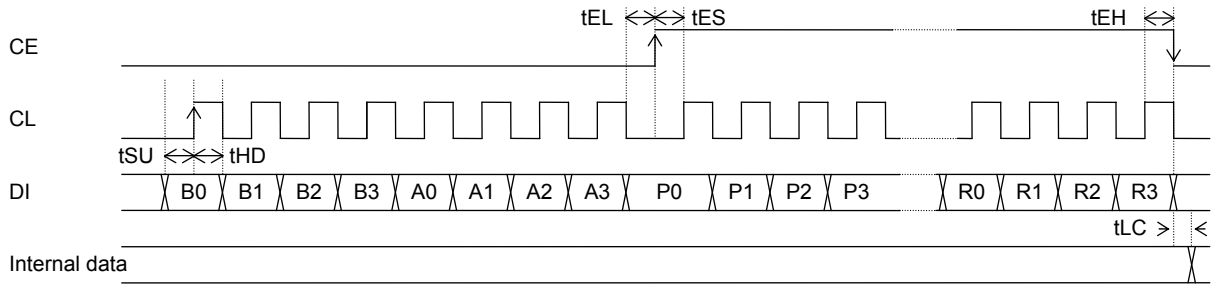

2. Serial Data Output (OUT) t_{SU} , t_{HD} , t_{EL} , t_{ES} , $t_{EH} \geq 0.75\mu s$ t_{DC} , $t_{DH} < 0.35\mu s$

(1) CL: Normal high

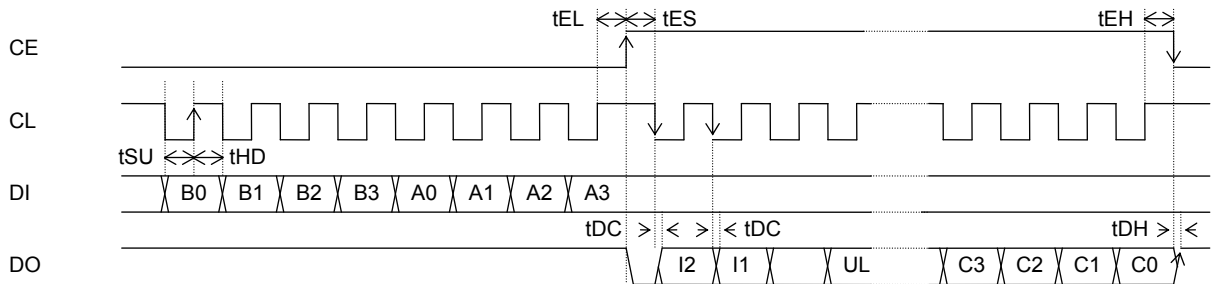

(2) CL: Normal low

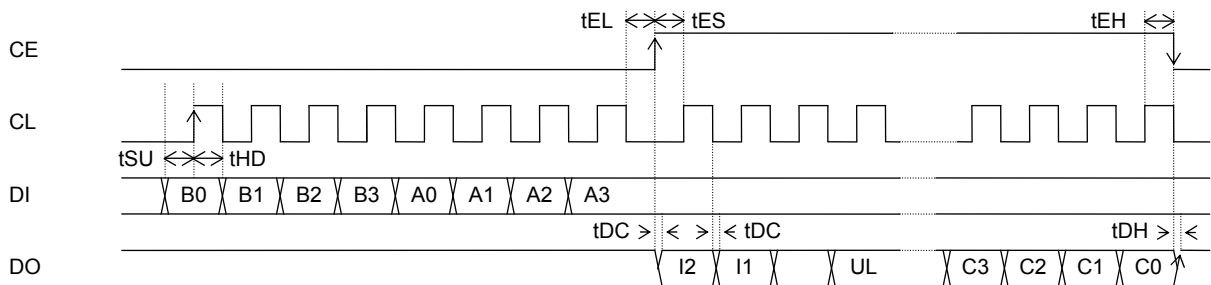

Note: Since the DO pin is an N-channel open-drain pin, the time for the data to change (t_{DC} and t_{DH}) will differ depending on the value of the pull-up resistor and printed circuit board capacitance.

LC72131K, LC72131KMA

Programmable Divider Structure

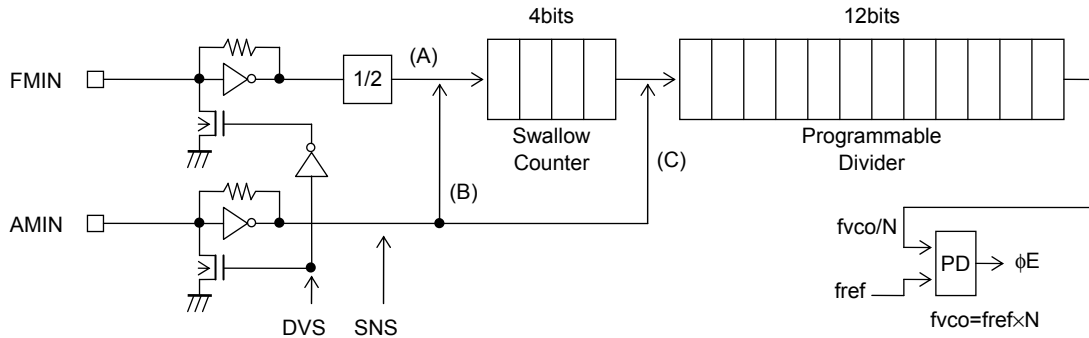

	DVS	SNS	Input pin	Set divisor	Actual divisor: N	Input frequency range
(A)	1	*	FMIN	272 to 65535	Twice the set value	10 to 160MHz
(B)	1	1	AMIN	272 to 65535	The set value	2 to 40MHz
(C)	0	0	AMIN	4 to 4095	The set value	0.5 to 10MHz

*: Don't care

Programmable Divider Calculation Examples

(1) FM, 50kHz steps (DVS=1, SNS=*: FMIN selected)

FM RF=90.0MHz (IF=+10.7MHz)

FM VCO=100.7MHz

PLL fref=25kHz (R0 to R1=1, R2 to R3=0)

100.7MHz (FMVCO) ÷ 25kHz (fref) ÷ 2 (FMIN: divide-by-two prescaler) = 2014 → 07DE (HEX)

E				D				7				0				SNS	DVS	CTE	XS	R0	R1	R2	R3
0	1	1	1	1	0	1	1	1	1	1	0	0	0	0	0	*	1			1	1	0	0
P0	P1	P2	P3	P4	P5	P6	P7	P8	P9	P10	P11	P12	P13	P14	P15	SNS	DVS	CTE	XS	R0	R1	R2	R3

(2) SW 5kHz steps (DVS=0, SNS=1: AMIN high-speed side selected)

SW RF=21.75MHz (IF=+450kHz)

SW VCO=22.20MHz

PLL fref=5kHz (R0=R2=0, R1=R3=1)

22.2MHz (SW VCO) ÷ 5kHz (fref) = 4440 → 1158 (HEX)

8				5				1				1				SNS	DVS	CTE	XS	R0	R1	R2	R3
0	0	0	1	1	0	1	0	1	0	0	0	1	0	0	0	1	0			0	1	0	1
P0	P1	P2	P3	P4	P5	P6	P7	P8	P9	P10	P11	P12	P13	P14	P15	SNS	DVS	CTE	XS	R0	R1	R2	R3

(3) MW 10kHz steps (DVS=0, SNS=0: AMIN low-speed side selected)

MW RF=1000kHz (IF=+450kHz)

MW VCO=1450kHz

PLL fref=10kHz (R0 to R2=0, R3=1)

1450kHz (MW VCO) ÷ 10kHz (fref) = 145 → 091 (HEX)

1				9				0				SNS	DVS	CTE	XS	R0	R1	R2	R3				
*	*	*	*	1	0	0	0	1	0	0	1	0	0	0	0	0	0			0	0	0	1
P0	P1	P2	P3	P4	P5	P6	P7	P8	P9	P10	P11	P12	P13	P14	P15	SNS	DVS	CTE	XS	R0	R1	R2	R3

IF Counter Structure

The LC72131K/KMA IF counter is a 20-bit binary counter. The result, i.e., the counter's msb, can be read serially from the DO pin.

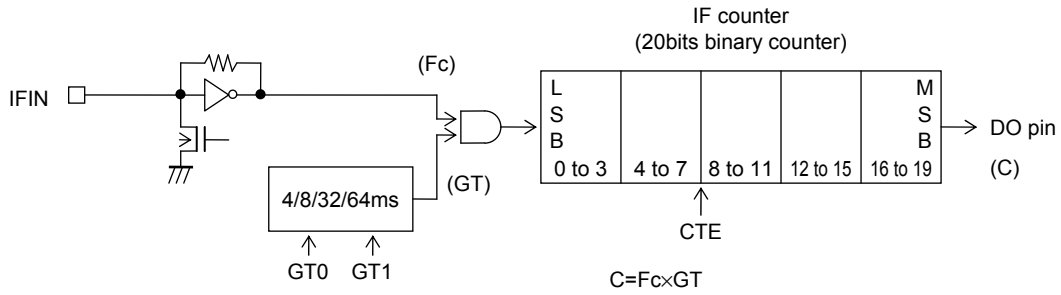

GT1	GT0	Measurement time	
		Measurement time (GT) (ms)	Wait time (twu) (ms)
0	0	4	3 to 4
0	1	8	3 to 4
1	0	32	7 to 8
1	1	64	7 to 8

The IF frequency (F_c) is measured by determining how many pulses were input to an IF counter in a specified measurement period, GT.

$$F_c = \frac{C}{GT} \quad (C = F_c \times GT) \quad C: \text{Count value (number of pulses)}$$

IF Counter Frequency Calculation Examples

- (1) When the measurement period (GT) is 32ms, the count (C) is 53980 hexadecimal (342400 decimal):
IF frequency (F_c) = $342400 \div 32\text{ms} = 10.7\text{MHz}$

				5				3				9				8				0							
				0	1	0	1	0	0	1	1	1	0	0	1	1	0	0	0	0	0	0	0	0	0	0	0
I2	I1	UL		C19	C18	C17	C16	C15	C14	C13	C12	C11	C10	C9	C8	C7	C6	C5	C4	C3	C2	C1	C0				

- (2) When the measurement period (GT) is 8ms, the count (C) is E10 hexadecimal (3600 decimal):
IF frequency (F_c) = $3600 \div 8\text{ms} = 450\text{kHz}$

				0				0				E				1				0			
				0	0	0	0	0	0	0	0	1	1	1	0	0	0	0	1	0	0	0	0
I2	I1	UL		C19	C18	C17	C16	C15	C14	C13	C12	C11	C10	C9	C8	C7	C6	C5	C4	C3	C2	C1	C0

IF Counter Operation

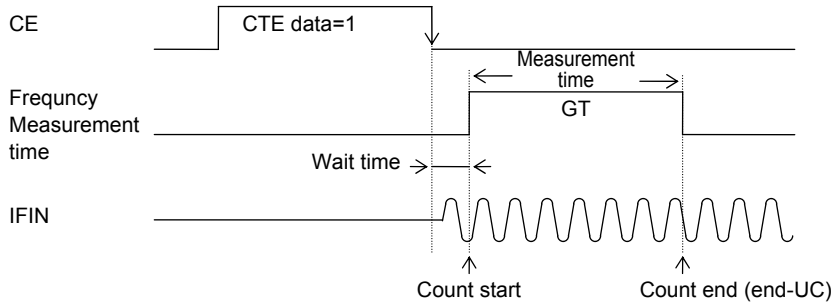

Before starting the IF count, the IF counter must be reset in advance by setting CTE in the serial data to 0. The IF count is started by changing the CTE bit in the serial data from 0 to 1. The serial data is latched by the LC72131K/KMA when the CE pin is dropped from high to low. The IF signal must be supplied to the IFIN pin in the period between the point the CE pin goes low and the end of the wait time at the latest. Next, the value of the IF counter at the end of the measurement period must be read out during the period that CTE is 1. This is because the IF counter is reset when CTE is set to 0.

Note: When operating the IF counter, the control microprocessor must first check the state of the IF-IC SD (station detect) signal and only after determining that the SD signal is present turn on IF buffer output and execute an IF count operation. Autosearch techniques that use only the IF counter are not recommended, since it is possible for IF buffer leakage output to cause incorrect stops at points where there is no station.

IFIN minimum input sensitivity standard f [MHz]

IFS	0.4 ≤ f < 0.5	0.5 ≤ f < 8	8 ≤ f ≤ 12
1: Normal mode	40mVrms (0.1 to 3mVrms)	40mVrms	40mVrms (1 to 10mVrms)
0: Degradation mode	70mVrms (10 to 15mVrms)	70mVrms	70mVrms (30 to 40mVrms)

Note: Values in parentheses are actual performance values presented as reference data.

Unlock Detection Timing

Unlock Detection Determination Timing

Unlocked state detection is performed in the reference frequency (f_{ref}) period (interval). Therefore, in principle, unlock determination requires a time longer than the period of the reference frequency. However, immediately after changing the divisor N (frequency) unlock detection must be performed after waiting at least two periods of the reference frequency.

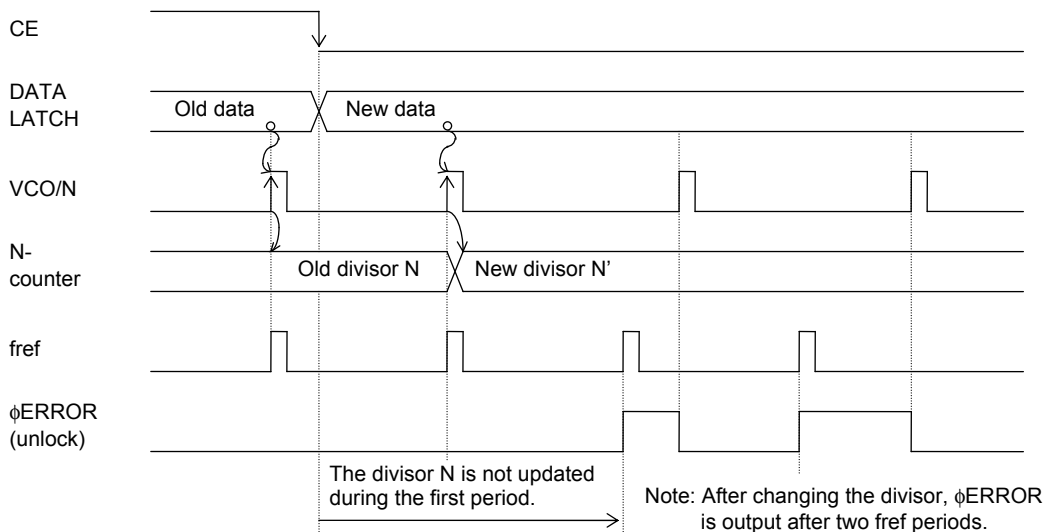

Figure 1 Unlocked State Detection Timing

For example, if f_{ref} is 1kHz, i.e., the period is 1ms, after changing the divisor N, the system must wait at least 2ms before checking for the unlocked state.

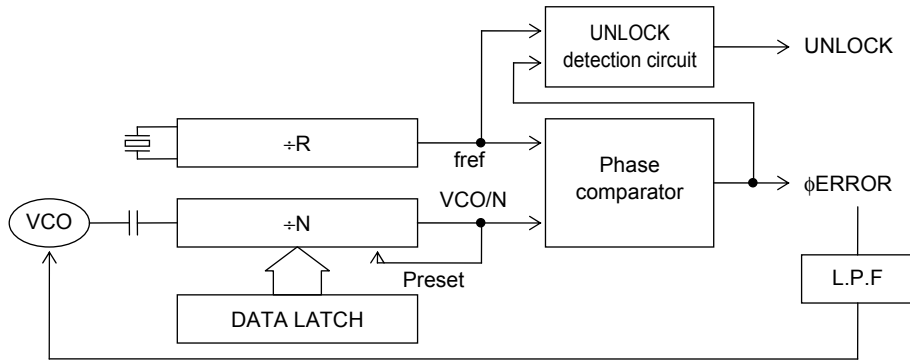

Figure 2 Circuit Structure

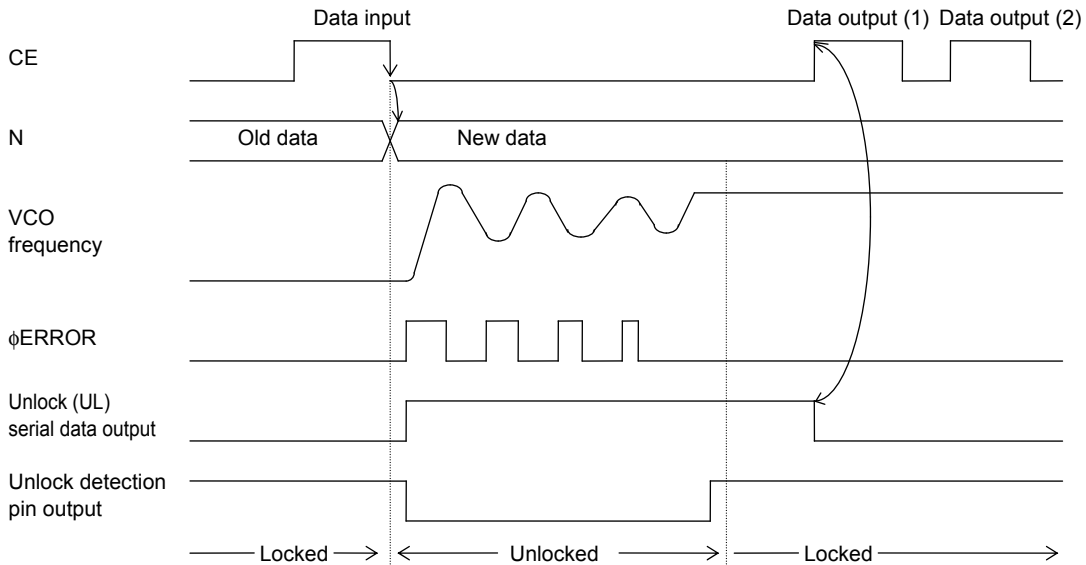

Figure 3

Unlocked State Data Output Using Serial Data Output

In the LC72131K/KMA, once an unlocked state occurs, the unlocked state serial data (UL) will not be reset until a data input (or output) operation is performed. At the data output (1) point in Figure 3, although the VCO frequency has stabilized (locked), since no data output has been performed since the divisor N was changed the unlocked state data remains in the unlocked state. As a result, even though the frequency has stabilized (locked), the system remains (from the standpoint of the data) in the unlocked state.

Therefore, the unlocked state data acquired at data output (1), which occurs immediately after the divisor N was changed, should be treated as a dummy data output and ignored. The second data output (data output (2)) and following outputs are valid data.

<Locked State Determination Flowchart Example>

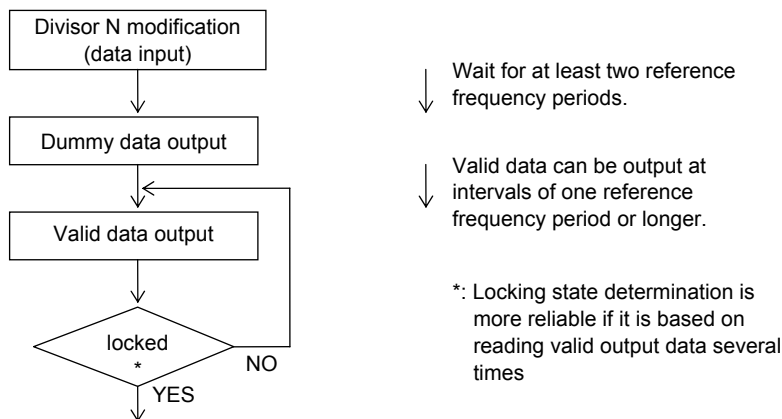

LC72131K, LC72131KMA

Directly Outputting Unlocked State Data from the DO Pin (Set by the DO pin control data)

Since the unlocked state (high=locked, low=unlocked) is output directly from the DO pin, the dummy data processing described in section 3 above is not required. After changing the divisor N, the locking state can be checked after waiting at least two reference frequency periods.

Clock Time Base Usage Notes

The pull-up resistor used on the clock time base output pin ($\overline{\text{BO1}}$) should be at least 100k Ω . This is to prevent degrading the VCO C/N characteristics when a loop filter is formed using the built-in low-pass filter transistor. Since the clock time base output pin and the low-pass filter have a common ground internal to the IC, it is necessary to minimize the time base output pin current fluctuations and to suppress their influence on the low-pass filter. Also, to prevent chattering we recommend using a Schmitt input at the controller (microprocessor) that receives this signal.

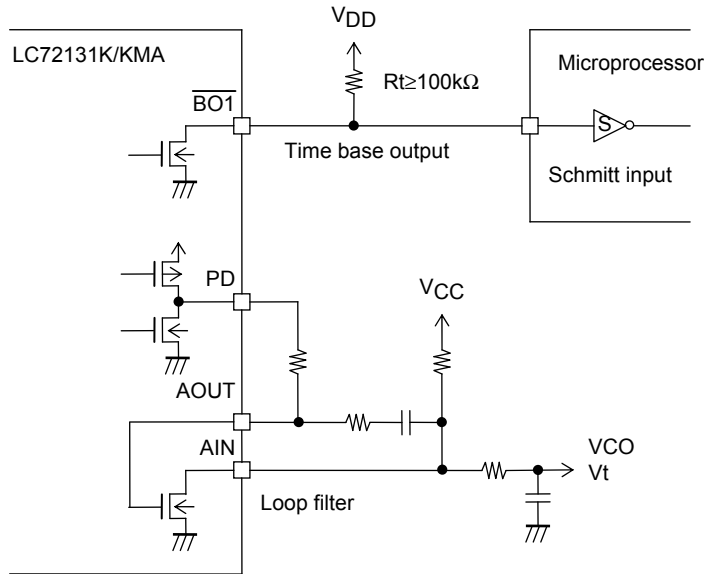

Other Items

[1] Notes on the Phase Comparator Dead Zone

DZ1	DZ0	Dead zone mode	Charge pump	Dead zone
0	0	DZA	ON/ON	-0s
0	1	DZB	ON/ON	-0s
1	0	DZC	OFF/OFF	+0s
1	1	DZD	OFF/OFF	++0s

Since correction pulses are output from the charge pump even if the PLL is locked when the charge pump is in the ON/ON state, the loop can easily become unstable. This point requires special care when designing application circuits.

The following problems may occur in the ON/ON state.

- (1) Side band generation due to reference frequency leakage
- (2) Side band generation due to both the correction pulse envelope and low frequency leakage

Schemes in which a dead zone is present (OFF/OFF) have good loop stability, but have the problem that acquiring a high C/N ratio can be difficult. On the other hand, although it is easy to acquire a high C/N ratio with schemes in which there is no dead zone, it is difficult to achieve high loop stability. Therefore, it can be effective to select DZA or DZB, which have no dead zone, in applications which require an FM S/N ratio in excess of 90 to 100dB, or in which an increased AM stereo pilot margin is desired. On the other hand, we recommend selecting DZC or DZD, which provide a dead zone, for applications which do not require such a high FM signal-to-noise ratio and in which either AM stereo is not used or an adequate AM stereo pilot margin can be achieved.

LC72131K, LC72131KMA

Dead Zone

The phase comparator compares f_p to a reference frequency (f_r) as shown in Figure 1. Although the characteristics of this circuit (see Figure 2) are such that the output voltage is proportional to the phase difference ϕ (line A), a region (the dead zone) in which it is not possible to compare small phase differences occurs in actual ICs due to internal circuit delays and other factors (line B). A dead zone as small as possible is desirable for products that must provide a high S/N ratio.

However, since a larger dead zone makes this circuit easier to use, a larger dead zone is appropriate for popularly-priced products. This is because it is possible for RF signals to leak from the mixer to the VCO and modulate the VCO in popularly-priced products in the presence of strong RF inputs. When the dead zone is narrow, the circuit outputs correction pulses and this output can further modulate the VCO and generate beat frequencies with the RF signal.

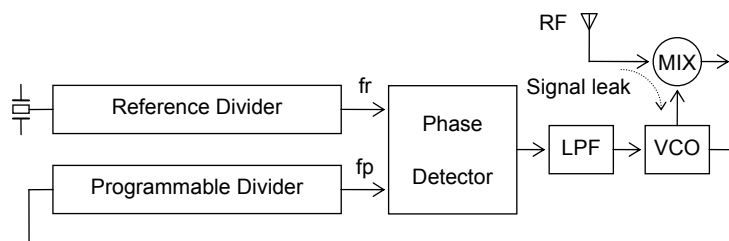

Figure 1

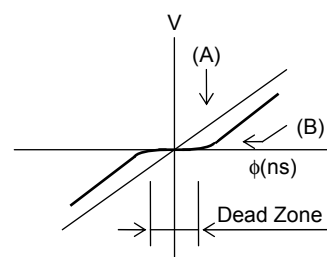

Figure 2

[2] Notes on the FMIN, AMIN, and IFIN Pins

Coupling capacitors must be placed as close as possible to their respective pin. A capacitance of about 100pF is desirable. In particular, if a capacitance of 1000pF or over is used for the IF pin, the time to reach the bias level will increase and incorrect counting may occur due to the relationship with the wait time.

[3] Notes on IF Counting → SD must be used in conjunction with the IF counting time

When using IF counting, always implement IF counting by having the microprocessor determine the presence of the IF-IC SD (station detect) signal and turn on the IF counter buffer only if the SD signal is present. Schemes in which auto-searches are performed with only IF counting are not recommended, since they can cause false detection where there is no signal due to overflow from the IF counter buffer.

[4] DO Pin Usage Techniques

In addition to data output mode times, the DO pin can also be used to check for IF counter count completion and for unlock detection output. Also, an input pin state can be output unchanged through the DO pin and input to the controller.

Pin States After the Power ON Reset [LC72131K]

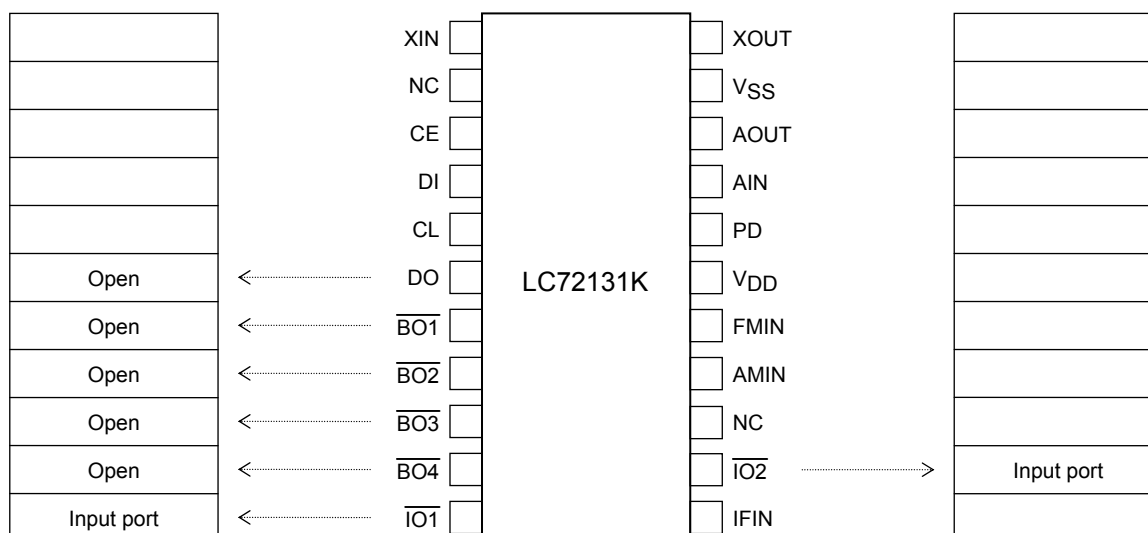

LC72131K, LC72131KMA

Pin States After the Power ON Reset [LC72131KMA]

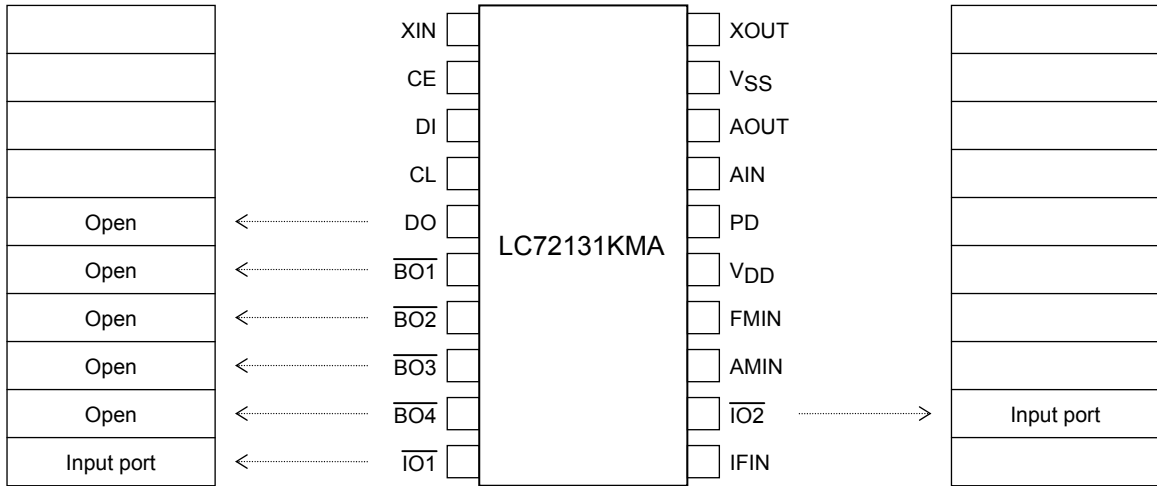

Application System Example [LC72131K]

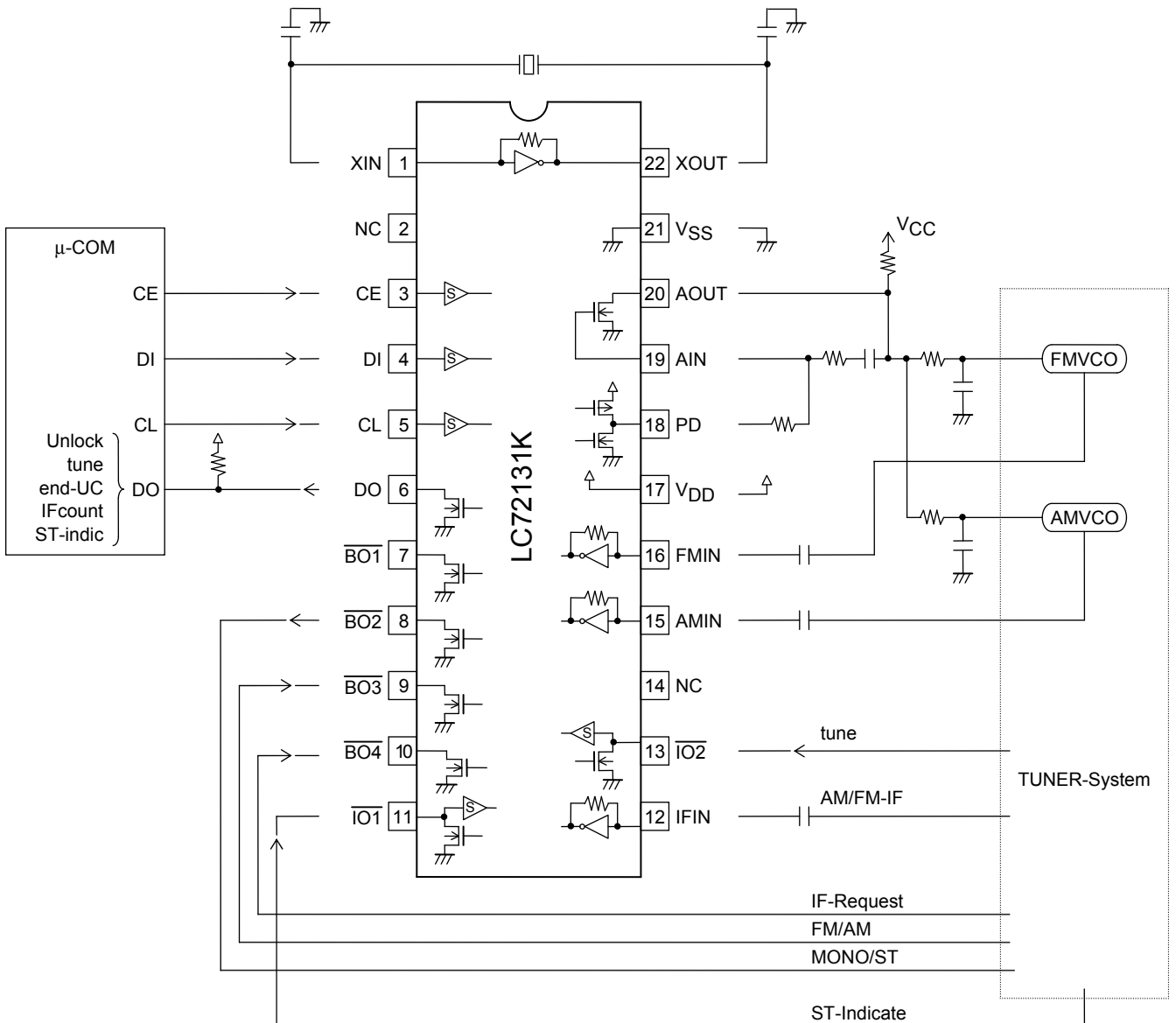

LC72131K, LC72131KMA

Application System Example [LC72131KMA]

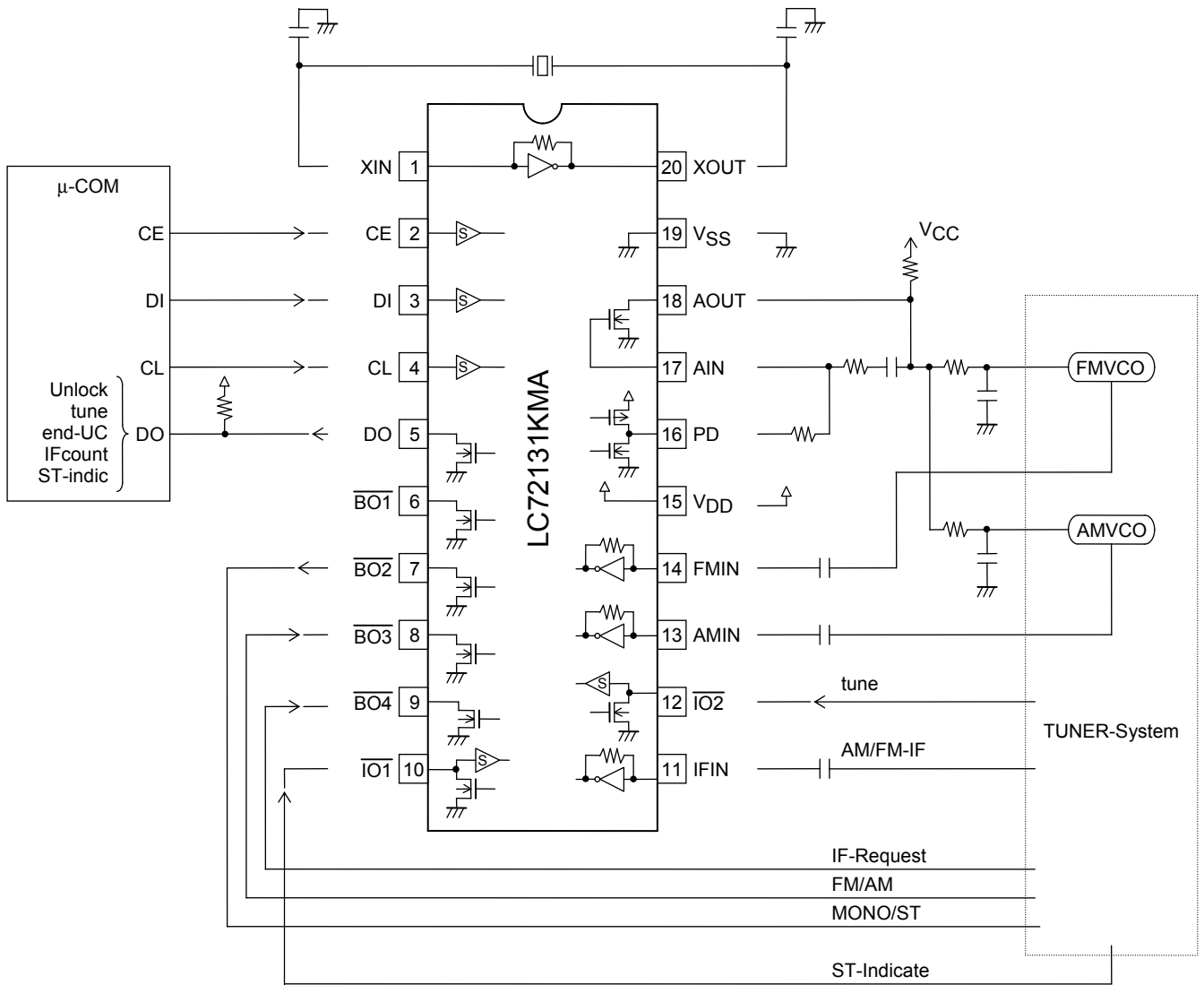

ON Semiconductor and the ON logo are registered trademarks of Semiconductor Components Industries, LLC (SCILLC). SCILLC owns the rights to a number of patents, trademarks, copyrights, trade secrets, and other intellectual property. A listing of SCILLC's product/patent coverage may be accessed at www.onsemi.com/site/pdf/Patent-Marking.pdf. SCILLC reserves the right to make changes without further notice to any products herein. SCILLC makes no warranty, representation or guarantee regarding the suitability of its products for any particular purpose, nor does SCILLC assume any liability arising out of the application or use of any product or circuit, and specifically disclaims any and all liability, including without limitation special, consequential or incidental damages. "Typical" parameters which may be provided in SCILLC data sheets and/or specifications can and do vary in different applications and actual performance may vary over time. All operating parameters, including "Typicals" must be validated for each customer application by customer's technical experts. SCILLC does not convey any license under its patent rights nor the rights of others. SCILLC products are not designed, intended, or authorized for use as components in systems intended for surgical implant into the body, or other applications intended to support or sustain life, or for any other application in which the failure of the SCILLC product could create a situation where personal injury or death may occur. Should Buyer purchase or use SCILLC products for any such unintended or unauthorized application, Buyer shall indemnify and hold SCILLC and its officers, employees, subsidiaries, affiliates, and distributors harmless against all claims, costs, damages, and expenses, and reasonable attorney fees arising out of, directly or indirectly, any claim of personal injury or death associated with such unintended or unauthorized use, even if such claim alleges that SCILLC was negligent regarding the design or manufacture of the part. SCILLC is an Equal Opportunity/Affirmative Action Employer. This literature is subject to all applicable copyright laws and is not for resale in any manner.