



ON Semiconductor®

<http://onsemi.com>

LV23200T

Bi-CMOS IC

1-chip Tuner IC incorporating PLL for Home Stereo System

Overview

The LV23200T is a one-chip tuner IC incorporating PLL for home stereo system.

Functions

- AM tuner Changeover of the constant in RFAMP, MIX, OSC, IF AMP, DET, AGC, SD, OSC BUFF, IF BUFF, and AGC modes.
- FM tuner 1stIFAMP, IF limiter AMP, DET (COIL type) , S-METER, SD, AFC, IF BUFF.
- MPX PLL STEREO DECODER, forced MONO, AUDIO MUTE, function to prevent interference from a neighboring station, PILOT canceling function.
- PLL frequency synthesizer.

Features

- Tuner IC and PLL IC integrated into one chip.
- MPX-VCO incorporated and without need of adjustment.
- FM/AM output level independent setting possible.
- MOS transistor for active LPF incorporated.

Specifications

Maximum Ratings at $T_a = 25\text{ }^\circ\text{C}$

Parameter	Symbol	Conditions	Ratings	Unit
Maximum supply voltage	$V_{CC\text{ max}}$	V_{CC}	7.0	V
	$V_{DD\text{ max}}$	V_{DD}	6.0	V
Operating temperature	T_{opr}		-20 to +80	$^\circ\text{C}$
Storage temperature	T_{stg}		-40 to +125	$^\circ\text{C}$

Stresses exceeding Maximum Ratings may damage the device. Maximum Ratings are stress ratings only. Functional operation above the Recommended Operating Conditions is not implied. Extended exposure to stresses above the Recommended Operating Conditions may affect device reliability.

LV23200T

Operating Condition at Ta = 25 °C

Parameter	Symbol	Conditions	Ratings	Unit
Recommended supply voltage	V _{CC}		5.0	V
	V _{DD}		3.0	V
Operating supply voltage range	V _{CC} op		4.5 to 6.0	V
	V _{DD} op1	X'tal oscillation = 4.5MHz	2.7 to 3.3	V

* Handle pin 34 with care because its electrostatic voltage at C = 200pF and R = 0Ω is 110 V.

Operating Characteristics at Ta = 25°C, V_{CC} = 5.0V, V_{DD} = 3.0V

Parameter	Symbol	Conditions	Ratings			Unit
			min	typ	max	
[Current dissipation]						
FM tuner block	I _{CC} FM	No input in FM mode	25	35	45	mA
AM tuner block	I _{CC} AM	No input in AM mode	14	24	34	mA
PLL block	I _{DD} FM	X'tal = 4.5MHz, No input at tuner	2.0	3.0	4.0	mA
[FM-FE characteristics (MPX)] : FM-IF (5PIN) input, fc = 10.7MHz, fm = 1kHz, 75kHzdev (L+R = 90%, Pilot = 10%)						
Demodulation output	V _O	V _{IN} = 100dBμV	450	550	650	mVrms
3dB sensitivity 1	LS1	V _{IN} = 70dBμV reference, input at -3dB *at input of FIFA (pin 1)		28	33	dBμV
3dB sensitivity 2	LS2	V _{IN} = 100dBμV reference, input at -3dB *at input of FMFA (pin 5)		35	40	dBμV
Total harmonic distortion	THD1	V _{IN} = 100dBμV, MONO		0.4	1.5	%
Signal-to-noise ratio	S/N	V _{IN} = 100dBμV	70	76		dB
AM suppression ratio	AMR	V _{IN} = 100dBμV, AM = 30%	36	40		dB
SD sensitivity	SD-1	0%mod, SD sensitivity mode 1	43	50	57	dBμV
Total harmonic distortion	THD2	V _{IN} = 100dBμV, MAIN-MOD		0.5	1.5	%
Separation	SEP	V _{IN} = 100dBμV, L output/R output	30	45		dB
ST sensitivity	VL	V _{IN} = 100dBμV, (L+R)+Pilot		3.0	5.5	%
Mute attenuation	MUTE	V _{IN} = 100dBμV, L output		60		dB
Carrier leakage	CL	V _{IN} = 100dBμV, (L+R)+Pilot	30	40		dB
[AM characteristics] : fc = 999kHz, fm = 1kHz, 30%mod						
Demodulation output 1	V _O 1	V _{IN} = 23dBμV, 30%mod, fm = 1kHz	50	80	130	mVrms
Demodulation output 2	V _O 2	V _{IN} = 80dBμV, 30%mod, fm = 1kHz	170	240	310	mVrms
Signal-to-noise ratio 1	S/N1	V _{IN} = 23dBμV	15	20		dB
Signal-to-noise ratio 2	S/N2	V _{IN} = 80dBμV	48	54		dB
Total harmonic distortion	THD	V _{IN} = 80dBμV		0.4	1.3	%
SD sensitivity	SD-ON	0%mod (Internally fixed sensitivity)	14	24	34	dBμV
[PLL characteristics]						
Internal return resistance	R _f	XIN		8		MΩ
Built-in output resistance	R _d	XOUT		250		kΩ
Hysteresis width	V _{HIS}	CE, CL, DI		0.1V _{DD}		V
Output high level voltage	V _{OH}	PD ; I _O = -1mA	V _{DD} -1.0			V
Output low level voltage	V _{OL} 1	PD ; I _O = 1mA			1.0	V
	V _{OL} 2	BO ; I _O = 1mA			0.25	V
		BO ; I _O = 5mA			1.25	V
	V _{OL} 3	DO ; I _O = 1mA			0.25	V
V _{OL} 4	AOUT ; I _O = 1mA, AIN = 2.0V			0.5	V	
Output high level current	I _I H1	CE, CL, DI ; V _I = 6.0V			5.0	μA
	I _I H2	XIN ; V _I = V _{DD}	0.16		0.9	μA
	I _I H3	AIN ; V _I = 6.0V			200	nA
Input high level current	I _I L1	CE, CL, DI ; V _I = 0V			5.0	μA
	I _I L2	XIN ; V _I = 0V	0.16		0.9	μA
	I _I L3	AIN ; V _I = 0V			200	nA

Continued on next page.

LV23200T

Continued from preceding page.

Parameter	Symbol	Conditions	Ratings			Unit
			min	typ	max	
Output off-leak current	I_{OFF1}	BO, AOUT ; $V_O = 10V$			5.0	μA
	I_{OFF2}	DO ; $V_O = 6.0V$			5.0	μA
"H" level 3-state off-leak current	I_{OFFH}	PD ; $V_O = 6.0V$		0.01	200	nA
"L" level 3-state off-leak current	I_{OFFL}	PD ; $V_O = 0V$		0.01	200	nA

Package Dimensions

unit : mm

3253B

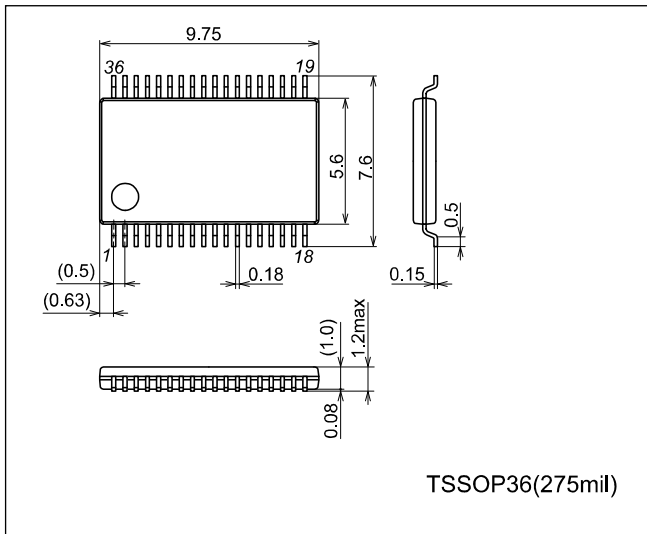

LV23200T

Description of Pin Functions

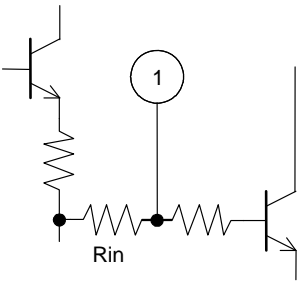
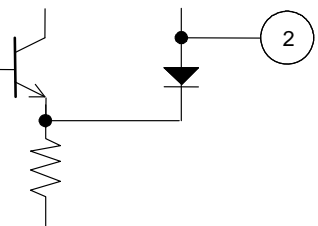
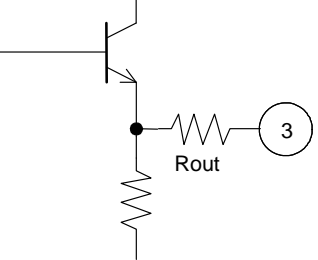
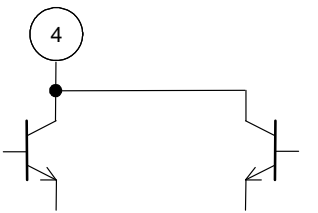
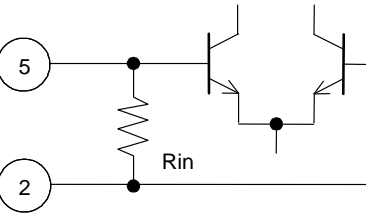
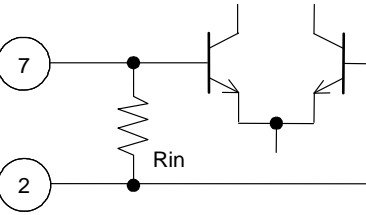
No.	Functions	Voltage (V)	Internal Equivalent Circuit	Remarks
1	FM 1stIF-AMP input	1.6V		Input impedance r_i (R_{in}). $R_{in} = 330\Omega$
2	REG	2.2V		Reference voltage of AM/FM IF/MPX block. $V_{reg} = 2.2V$
3	FM 1st IF-AMP output	3.0V		Output impedance r_o (R_{out}). $R_{out} = 300\Omega$
4	AM MIX output	V_{CC}		MIX coil used between pins 4 and 8 (V_{CC} voltage).
5	FM IF input	V_{reg}		Input impedance r_i (R_{in}). $R_{in} = 330\Omega$
6	GND	0V		AM/FM IF/MPX block GND
7	AM IF input	2.2V		Input impedance r_i (R_{in}). $R_{in} = 2k\Omega$
8	V_{CC}	5.0V		AM/FM IF/MPX block V_{CC}

Continued on next page.

LV23200T

Continued from preceding page.

No.	Functions	Voltage (V)	Internal Equivalent Circuit	Remarks
9	FM DET	V_{CC}		Recommended detection coil. 600BCAS-10790Z
10	Phase comparator filter	$V_{CC}-1.0V$		$R = 10k\Omega$
11	Pilot filter	$V_{CC}-1.0V$		$R = 10k\Omega$
12 13	L output R output	2.5V		Output impedance r_o (Rout). $R_{out} = 7.7k\Omega$
15	CE	-		Chip enable pin At changeover from "L" to "H": Address latching. At changeover from "H" to "L": Data latching.
16	DI	-		Serial data input pin Sets data in synchronization with rise of data clock.
17	CL	-		Data clock input pin.
18	DO	-		Data output pin Outputs various data in synchronization with fall of data clock in the OUT mode.

Continued on next page.

LV23200T

Continued from preceding page.

No.	Functions	Voltage (V)	Internal Equivalent Circuit	Remarks
19 20	X IN X OUT	- -		Clock for internal reference Connect a 4.5 MHz crystal oscillator.
21	V _{DD}	3.0V		AM/FM IF/MPX block V _{DD}
22	Pilot canceling output	V _{reg}		Output impedance r_o (R _{out}). R _{out} = 30k Ω
23	AM detection output	0.8V (FM) V _{reg} (AM)		Output impedance r_o (R _{out}). R _{out} = 10k Ω
24	MPX input	V _{reg}		MPX inverse input pin. RNF = 20k Ω
25	PLL input	V _{reg}		Input impedance r_i (R _{in}). R _{in} = 20k Ω
26	FM detection output	V _{reg} +0.7V		Output impedance r_o (R _{out}). R _{out} = 3.3k Ω Adjusts separation using the capacitance value of a section between this pin and GND.

Continued on next page.

LV23200T

Continued from preceding page.

No.	Functions	Voltage (V)	Internal Equivalent Circuit	Remarks
27	SD monitor	V_{DD}		Active "L" Open collector.
28	FMS meter and AM AGC outputs	0.2V (FM) 0.8V (AM)		Internal load resistance $R = 13.9k\Omega$ Determines the SD response speed during SEEK by a capacitor externally connected to pin 28.
29	PD	-		PLL charge pump output pin.
30 31	AIN AOUT	- -		Nch MOS transistor for PLL active low pass filter.
32	AM OSC	V_{CC}		OSC coil used between pins 32 and 8 (V_{CC} voltage).
33	AFC	V_{reg}		Enables adjustment of the FM SD band width by external resistor between pins 33 and 2 (V_{reg} voltage).

Continued on next page.

LV23200T

Continued from preceding page.

No.	Functions	Voltage (V)	Internal Equivalent Circuit	Remarks
34	AM RF input	Vreg		Use pin 34 with the same potential as for pin 32 (AFC voltage).
35	FM OSC input	V _{CC}		Use pin 35 through pull-up to pin 8 (V _{CC} voltage) by resistance load.
36	BO	-		Pin dedicated for output.

Composition of DI control data (serial data input)

(1) IN1 mode

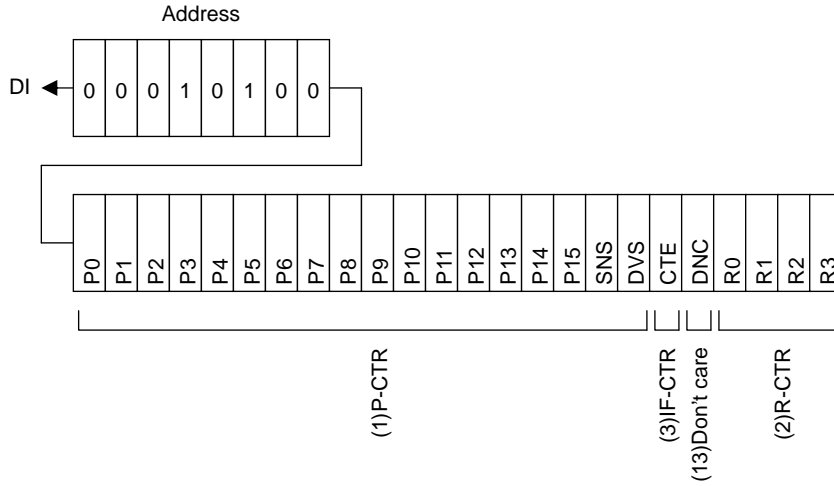

(2) IN2 mode

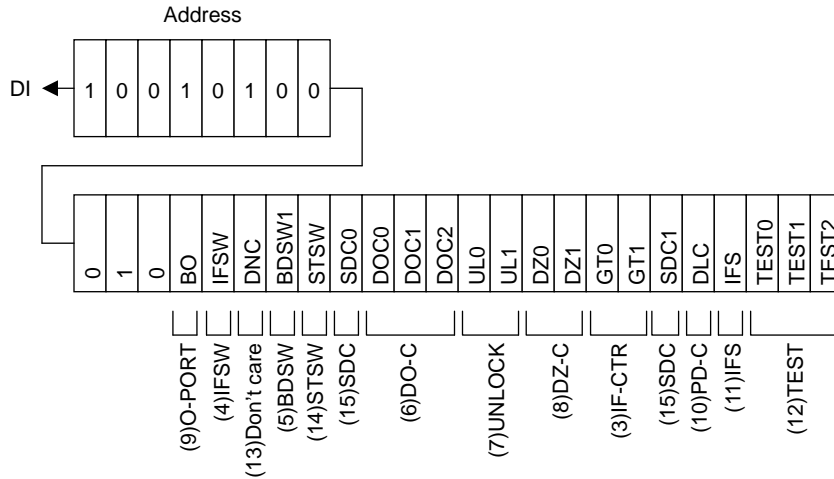

Description of DI control Data

No.	Control block data	Description	Related data																																				
(1)	Programmable divider data P0 to P15 DVS, SNS	<ul style="list-style-type: none"> Data to set the dividing number of programmable divider Binary value with P15 assumed to be MSB. LSB varies according to DVS and SNS. (* : Don't care) <table border="1"> <thead> <tr> <th>DVS</th> <th>SNS</th> <th>LSB</th> <th>set dividing number (N)</th> <th>Actual dividing</th> </tr> </thead> <tbody> <tr> <td>1</td> <td>*</td> <td>P0</td> <td>272 to 65535</td> <td>Twice the set value</td> </tr> <tr> <td>0</td> <td>1</td> <td>P0</td> <td>272 to 65535</td> <td>Set value</td> </tr> <tr> <td>0</td> <td>0</td> <td>P4</td> <td>4 to 4095</td> <td>Set value</td> </tr> </tbody> </table> <ul style="list-style-type: none"> * P0 to P3 invalid when LSB : P4 To select the signal input (FMIN, AMIN) to the programmable divider and to change the input frequency range. (* : Don't care) <table border="1"> <thead> <tr> <th>DVS</th> <th>SNS</th> <th>Input</th> <th>Operation frequency range</th> </tr> </thead> <tbody> <tr> <td>1</td> <td>*</td> <td>FMIN</td> <td>10 to 160MHz</td> </tr> <tr> <td>0</td> <td>1</td> <td>AMIN</td> <td>2 to 40MHz</td> </tr> <tr> <td>0</td> <td>0</td> <td>AMIN</td> <td>0.5 to 10MHz</td> </tr> </tbody> </table>	DVS	SNS	LSB	set dividing number (N)	Actual dividing	1	*	P0	272 to 65535	Twice the set value	0	1	P0	272 to 65535	Set value	0	0	P4	4 to 4095	Set value	DVS	SNS	Input	Operation frequency range	1	*	FMIN	10 to 160MHz	0	1	AMIN	2 to 40MHz	0	0	AMIN	0.5 to 10MHz	
DVS	SNS	LSB	set dividing number (N)	Actual dividing																																			
1	*	P0	272 to 65535	Twice the set value																																			
0	1	P0	272 to 65535	Set value																																			
0	0	P4	4 to 4095	Set value																																			
DVS	SNS	Input	Operation frequency range																																				
1	*	FMIN	10 to 160MHz																																				
0	1	AMIN	2 to 40MHz																																				
0	0	AMIN	0.5 to 10MHz																																				

Continued on next page.

LV23200T

Continued from preceding page.

No.	Control block data	Description	Related data																																																																																					
(2)	Reference divider data R0 to R3	<ul style="list-style-type: none"> Reference frequency (fref) selection data <table border="1" style="margin-left: 20px; border-collapse: collapse; text-align: center;"> <thead> <tr> <th>R3</th> <th>R2</th> <th>R1</th> <th>R0</th> <th>Reference frequency</th> </tr> </thead> <tbody> <tr><td>0</td><td>0</td><td>0</td><td>0</td><td>25kHz</td></tr> <tr><td>0</td><td>0</td><td>0</td><td>1</td><td>25kHz</td></tr> <tr><td>0</td><td>0</td><td>1</td><td>0</td><td>25kHz</td></tr> <tr><td>0</td><td>0</td><td>1</td><td>1</td><td>25kHz</td></tr> <tr><td>0</td><td>1</td><td>0</td><td>0</td><td>12.5kHz</td></tr> <tr><td>0</td><td>1</td><td>0</td><td>1</td><td>6.25kHz</td></tr> <tr><td>0</td><td>1</td><td>1</td><td>0</td><td>3.125kHz</td></tr> <tr><td>0</td><td>1</td><td>1</td><td>1</td><td>3.125kHz</td></tr> <tr><td>1</td><td>0</td><td>0</td><td>0</td><td>5kHz</td></tr> <tr><td>1</td><td>0</td><td>0</td><td>1</td><td>5kHz</td></tr> <tr><td>1</td><td>0</td><td>1</td><td>0</td><td>5kHz</td></tr> <tr><td>1</td><td>0</td><td>1</td><td>1</td><td>1kHz</td></tr> <tr><td>1</td><td>1</td><td>0</td><td>0</td><td>3kHz</td></tr> <tr><td>1</td><td>1</td><td>0</td><td>1</td><td>15kHz</td></tr> <tr><td>1</td><td>1</td><td>1</td><td>0</td><td>PLL INHIBIT+X'tal OSC</td></tr> <tr><td>1</td><td>1</td><td>1</td><td>1</td><td>PLL INHIBIT</td></tr> </tbody> </table> <ul style="list-style-type: none"> * PLL INHIBIT The programmable divider and IF counter stop, with FMIN, AMIN, HCTR and LCTR inputs being in the pull-down condition (GND), and the charge pump has the high impedance. 	R3	R2	R1	R0	Reference frequency	0	0	0	0	25kHz	0	0	0	1	25kHz	0	0	1	0	25kHz	0	0	1	1	25kHz	0	1	0	0	12.5kHz	0	1	0	1	6.25kHz	0	1	1	0	3.125kHz	0	1	1	1	3.125kHz	1	0	0	0	5kHz	1	0	0	1	5kHz	1	0	1	0	5kHz	1	0	1	1	1kHz	1	1	0	0	3kHz	1	1	0	1	15kHz	1	1	1	0	PLL INHIBIT+X'tal OSC	1	1	1	1	PLL INHIBIT	
R3	R2	R1	R0	Reference frequency																																																																																				
0	0	0	0	25kHz																																																																																				
0	0	0	1	25kHz																																																																																				
0	0	1	0	25kHz																																																																																				
0	0	1	1	25kHz																																																																																				
0	1	0	0	12.5kHz																																																																																				
0	1	0	1	6.25kHz																																																																																				
0	1	1	0	3.125kHz																																																																																				
0	1	1	1	3.125kHz																																																																																				
1	0	0	0	5kHz																																																																																				
1	0	0	1	5kHz																																																																																				
1	0	1	0	5kHz																																																																																				
1	0	1	1	1kHz																																																																																				
1	1	0	0	3kHz																																																																																				
1	1	0	1	15kHz																																																																																				
1	1	1	0	PLL INHIBIT+X'tal OSC																																																																																				
1	1	1	1	PLL INHIBIT																																																																																				
(3)	IF counter control data CTE GT0, GT1	<ul style="list-style-type: none"> IF counter counting start data CTE = 1 : Counting start = 0 : Counting start Determines the counting time of universal counter <table border="1" style="margin-left: 20px; border-collapse: collapse; text-align: center;"> <thead> <tr> <th>GT1</th> <th>GT0</th> <th>Counting time</th> <th>Wait time</th> </tr> </thead> <tbody> <tr><td>0</td><td>0</td><td>4ms</td><td>3 to 4ms</td></tr> <tr><td>0</td><td>1</td><td>8ms</td><td>3 to 4ms</td></tr> <tr><td>1</td><td>0</td><td>16ms</td><td>3 to 4ms</td></tr> <tr><td>1</td><td>1</td><td>32ms</td><td>3 to 4ms</td></tr> </tbody> </table>	GT1	GT0	Counting time	Wait time	0	0	4ms	3 to 4ms	0	1	8ms	3 to 4ms	1	0	16ms	3 to 4ms	1	1	32ms	3 to 4ms	IFS																																																																	
GT1	GT0	Counting time	Wait time																																																																																					
0	0	4ms	3 to 4ms																																																																																					
0	1	8ms	3 to 4ms																																																																																					
1	0	16ms	3 to 4ms																																																																																					
1	1	32ms	3 to 4ms																																																																																					
(4)	MUTE control data IFSW	<ul style="list-style-type: none"> Data to determine the output of output port IFSW, controlling the MUTE function. "Data" = 0 : at receiving 1 : MUTE 																																																																																						
(5)	FM/AM BAND selection control data BDSW	<ul style="list-style-type: none"> Data to determine the output of output port BDSW, controlling selection of BAND. "Data" = 0 : AM 1 : FM 																																																																																						

Continued on next page.

LV23200T

Continued from preceding page.

No.	Control block data	Description	Related data																																				
(6)	<p>DO pin control data</p> <p>DOC0 DOC1 DOC2</p>	<ul style="list-style-type: none"> Data to control DO pin output <table border="1" style="margin-left: 20px; border-collapse: collapse; width: 80%;"> <thead> <tr> <th>DOC2</th> <th>DOC1</th> <th>DOC0</th> <th>DO pin condition</th> </tr> </thead> <tbody> <tr> <td style="text-align: center;">0</td> <td style="text-align: center;">0</td> <td style="text-align: center;">0</td> <td>Open</td> </tr> <tr> <td style="text-align: center;">0</td> <td style="text-align: center;">0</td> <td style="text-align: center;">1</td> <td>Low when unlock is detected.</td> </tr> <tr> <td style="text-align: center;">0</td> <td style="text-align: center;">1</td> <td style="text-align: center;">0</td> <td>end-UC (See the item with asterisk below)</td> </tr> <tr> <td style="text-align: center;">0</td> <td style="text-align: center;">1</td> <td style="text-align: center;">1</td> <td>Open</td> </tr> <tr> <td style="text-align: center;">1</td> <td style="text-align: center;">0</td> <td style="text-align: center;">0</td> <td>Open</td> </tr> <tr> <td style="text-align: center;">1</td> <td style="text-align: center;">0</td> <td style="text-align: center;">1</td> <td>Low when SDON</td> </tr> <tr> <td style="text-align: center;">1</td> <td style="text-align: center;">1</td> <td style="text-align: center;">0</td> <td>Low when stereo</td> </tr> <tr> <td style="text-align: center;">1</td> <td style="text-align: center;">1</td> <td style="text-align: center;">1</td> <td>Open</td> </tr> </tbody> </table> <ul style="list-style-type: none"> The open condition is selected at power ON/reset. * IF counter counting end check <div style="text-align: center; margin: 10px 0;"> </div> <ol style="list-style-type: none"> ① With end-UC set and IF counter starting (CTE = 0→1), DO pin opens automatically. ② At end of counting of the IF counter, DO pin goes LOW and check on counting end can be made. ③ DO pin opens when serial data is entered/output (CE pin : Hi) <p>Note : DO pin is always in the open condition during data input (IN1 and IN2 modes, during CE : Hi period), regardless of DO pin control data (DOC0 to 2). In the DO pin condition during data output (OUT mode, CE-Hi period), the content of internal DO serial data is output in synchronization with CL pin signal, regardless of DO pin control data (DOC).</p>	DOC2	DOC1	DOC0	DO pin condition	0	0	0	Open	0	0	1	Low when unlock is detected.	0	1	0	end-UC (See the item with asterisk below)	0	1	1	Open	1	0	0	Open	1	0	1	Low when SDON	1	1	0	Low when stereo	1	1	1	Open	<p>UL0, UL1 CTE</p>
DOC2	DOC1	DOC0	DO pin condition																																				
0	0	0	Open																																				
0	0	1	Low when unlock is detected.																																				
0	1	0	end-UC (See the item with asterisk below)																																				
0	1	1	Open																																				
1	0	0	Open																																				
1	0	1	Low when SDON																																				
1	1	0	Low when stereo																																				
1	1	1	Open																																				
(7)	<p>Unlock detection data</p> <p>UL0, UL1</p>	<ul style="list-style-type: none"> Phase error (ϕE) detection width selection data to judge if PLL is locked. Phase error exceeding the detection width is judged to mean that PLL is locked (* : don't care) <table border="1" style="margin-left: 20px; border-collapse: collapse; width: 80%;"> <thead> <tr> <th>UL1</th> <th>UL0</th> <th>ϕE Detection width</th> <th>Detection output</th> </tr> </thead> <tbody> <tr> <td style="text-align: center;">0</td> <td style="text-align: center;">0</td> <td style="text-align: center;">Stop</td> <td style="text-align: center;">Open</td> </tr> <tr> <td style="text-align: center;">0</td> <td style="text-align: center;">1</td> <td style="text-align: center;">0</td> <td style="text-align: center;">Direct output of ϕE</td> </tr> <tr> <td style="text-align: center;">1</td> <td style="text-align: center;">*</td> <td style="text-align: center;">$\pm 6.67\mu s$</td> <td style="text-align: center;">ϕE extended by 1 to 2 ms</td> </tr> </tbody> </table> <p>* DO pin is LOW. Serial data output : UL = 0.</p>	UL1	UL0	ϕE Detection width	Detection output	0	0	Stop	Open	0	1	0	Direct output of ϕE	1	*	$\pm 6.67\mu s$	ϕE extended by 1 to 2 ms	<p>DOC0 DOC1 DOC2</p>																				
UL1	UL0	ϕE Detection width	Detection output																																				
0	0	Stop	Open																																				
0	1	0	Direct output of ϕE																																				
1	*	$\pm 6.67\mu s$	ϕE extended by 1 to 2 ms																																				
(8)	<p>Phase comparator control data</p> <p>DZ0, DZ1</p>	<ul style="list-style-type: none"> Data to control the dead zone of phase comparator <table border="1" style="margin-left: 20px; border-collapse: collapse; width: 80%;"> <thead> <tr> <th>DZ1</th> <th>DZ0</th> <th>Dead zone mode</th> </tr> </thead> <tbody> <tr> <td style="text-align: center;">0</td> <td style="text-align: center;">0</td> <td style="text-align: center;">DZA</td> </tr> <tr> <td style="text-align: center;">0</td> <td style="text-align: center;">1</td> <td style="text-align: center;">DZB</td> </tr> <tr> <td style="text-align: center;">1</td> <td style="text-align: center;">0</td> <td style="text-align: center;">DZC</td> </tr> <tr> <td style="text-align: center;">1</td> <td style="text-align: center;">1</td> <td style="text-align: center;">DZD</td> </tr> </tbody> </table> <p>Dead zone width : DZA<DZB<DZC<DZD</p>	DZ1	DZ0	Dead zone mode	0	0	DZA	0	1	DZB	1	0	DZC	1	1	DZD																						
DZ1	DZ0	Dead zone mode																																					
0	0	DZA																																					
0	1	DZB																																					
1	0	DZC																																					
1	1	DZD																																					
(9)	<p>Output port data</p> <p>BO</p>	<ul style="list-style-type: none"> Data to determine the output of output ports BO1 and BO2 <p>"Data" = 0 : OPEN 1 : Low</p>																																					
(10)	<p>Charge pump control data</p> <p>DLC</p>	<ul style="list-style-type: none"> Data to enforce control of charge pump output <table border="1" style="margin-left: 20px; border-collapse: collapse; width: 80%;"> <thead> <tr> <th>DLC</th> <th>Charge pump output</th> </tr> </thead> <tbody> <tr> <td style="text-align: center;">0</td> <td style="text-align: center;">Normal</td> </tr> <tr> <td style="text-align: center;">1</td> <td style="text-align: center;">Forced to LOW</td> </tr> </tbody> </table> <p>* In case of dead lock because of VCO oscillation stop when the VCO control voltage (V_{tune}) is 0V, it is possible to clear dead lock by setting the charge pump output to LOW and V_{tune} to V_{CC}. (Dead lock clear circuit)</p>	DLC	Charge pump output	0	Normal	1	Forced to LOW																															
DLC	Charge pump output																																						
0	Normal																																						
1	Forced to LOW																																						
(11)	<p>IFS</p>	<ul style="list-style-type: none"> Normally, set Data = 1. Setting Data = 0 causes the input sensitivity worsening mode and the sensitivity decreases by about 10 to 30mVrms. 																																					
(12)	<p>LSI test data</p> <p>TEST0 to 2</p>	<ul style="list-style-type: none"> LSI test data <table style="margin-left: 20px;"> <tr> <td style="border: none;">TEST0</td> <td rowspan="3" style="border: none; padding-left: 10px;">} All to be set to "0"</td> </tr> <tr> <td style="border: none;">TEST1</td> </tr> <tr> <td style="border: none;">TEST2</td> </tr> </table> <p>All set to zero at power ON/reset</p>	TEST0	} All to be set to "0"	TEST1	TEST2																																	
TEST0	} All to be set to "0"																																						
TEST1																																							
TEST2																																							
(13)	<p>DNC</p>	<ul style="list-style-type: none"> Set data = 0. 																																					

Continued on next page.

LV23200T

Continued from preceding page.

No.	Control block data	Description	Related data
(14)	Forced monaural control data STSW	<ul style="list-style-type: none"> Data to determine the output of output port STSW, controlling the forced stereo functions. "Data" = 0 : MONO 1 : STEREO 	
(15)	SD sensitivity control data SDC	<ul style="list-style-type: none"> Data to determine the output of output ports SDC, controlling the SD sensitivity "Data" = SDC0 : 0, SDC1 : 0 → SD sensitivity 1 = 50dBμV (Typ) SDC0 : 0, SDC1 : 1 → SD sensitivity 2 = 52dBμV (Typ) SDC0 : 1, SDC1 : 0 → SD sensitivity 3 = 57dBμV (Typ) SDC0 : 1, SDC1 : 1 → SD sensitivity 4 = 62dBμV (Typ) * Above data values indicate the difference of SD sensitivity levels and are reference values. 	

DO control data (serial data output) composition

(1) OUT mode

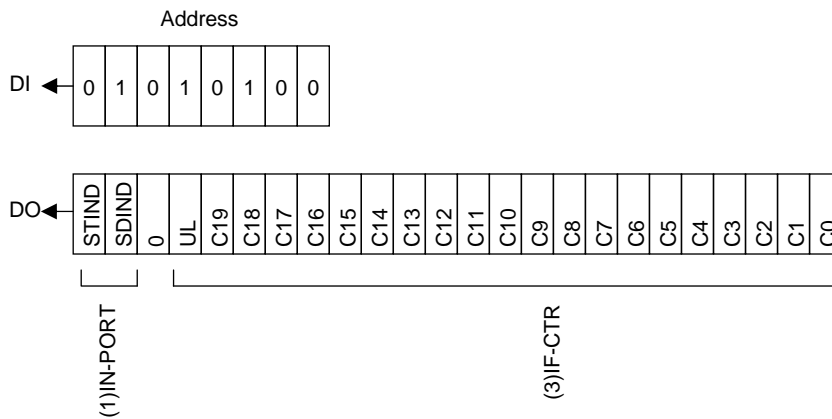

Description of DO output data

No.	Control block data	Description	Related data
(1)	Stereo and SD indicators control data STIND, SDIND	<ul style="list-style-type: none"> Data latching stereo and SD indicator conditions. Latching made in the data output (OUT) mode. SDIND←Stereo indicator condition 0 : ST ON, 1 : ST OFF STIND←SD indicator condition 0 : SD ON, 1 : SD OFF 	
(2)	PLL unlock data UL	<ul style="list-style-type: none"> Data latching the content of unlock detection circuit UL←0 : At unlock 1 : At lock or in the detection stop mode 	UL0 UL1
(3)	IF counter, binary counter C19 to C0	<ul style="list-style-type: none"> Data latching the content of IF counter (20-bit binary counter) C19←MSB of binary counter C0 ←LSB of binary counter 	CTE GT0 GT1

LV23200T

Serial data input (IN1/IN2) $t_{SU}, t_{HD}, t_{EL}, t_{ES}, t_{EH} \geq 0.75\mu s$ $t_{LC} < 0.75\mu s$

CL : Normally Hi

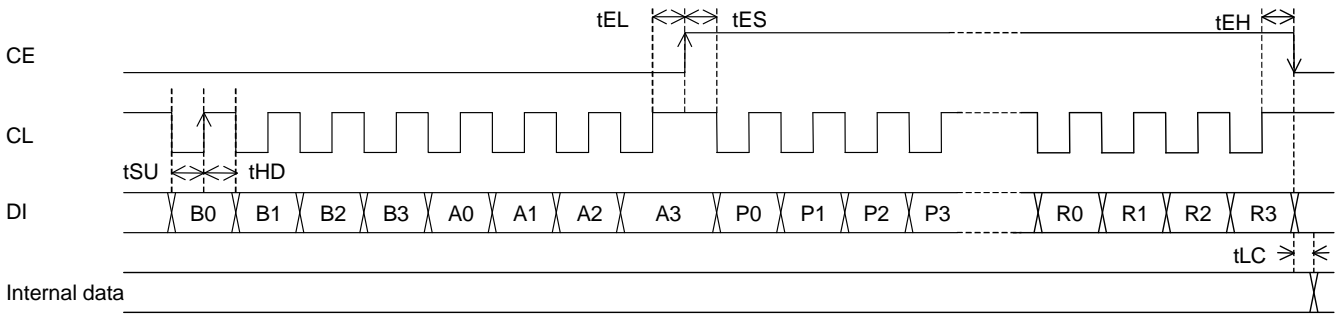

CL : Normally Low

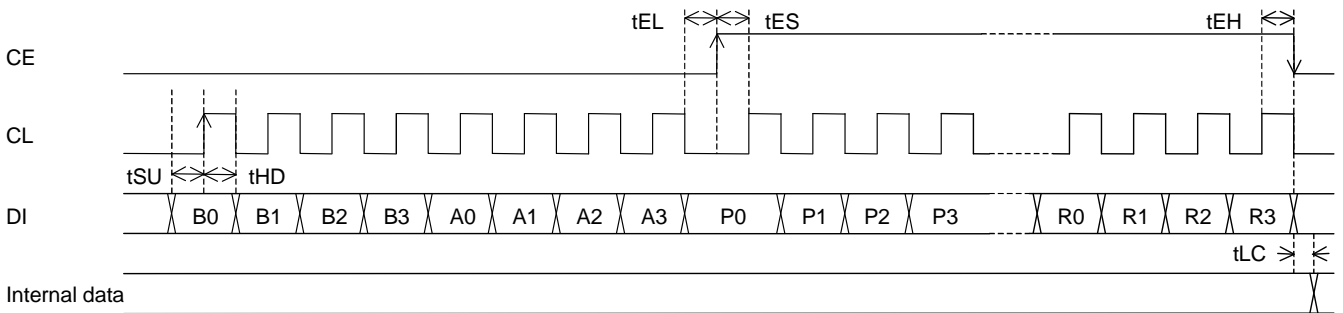

Serial data output (OUT) $t_{SU}, t_{HD}, t_{EL}, t_{ES}, t_{EH} \geq 0.75\mu s$ $t_{DC}, t_{DH} < 0.35\mu s$

CL : Normally Hi

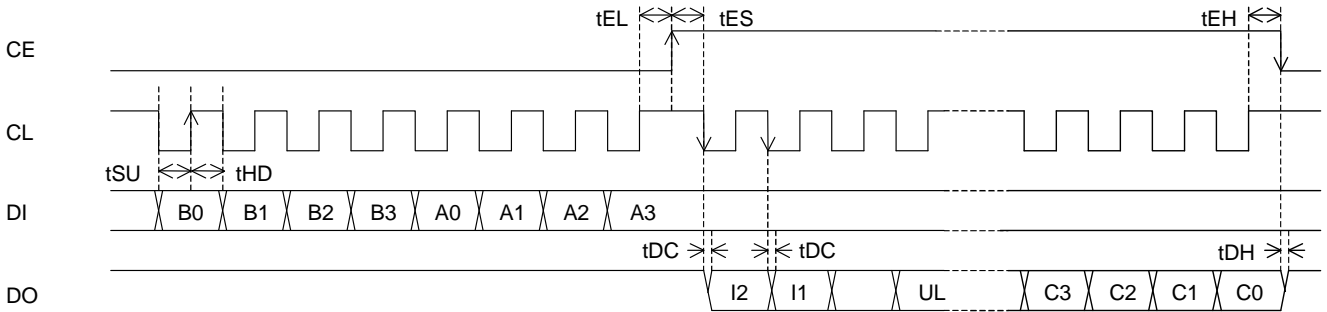

CL : Normally Hi

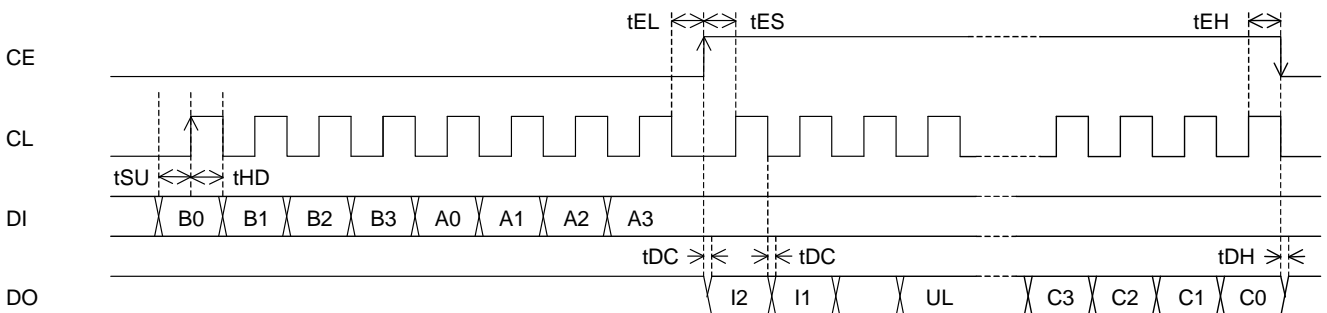

(Note) DO pin is an Nch open drain pin, so that the data varying time (t_{DC} and t_{DH}) differs depending on the pull-up resistance and substrate capacity.

LV23200T

Serial data timing

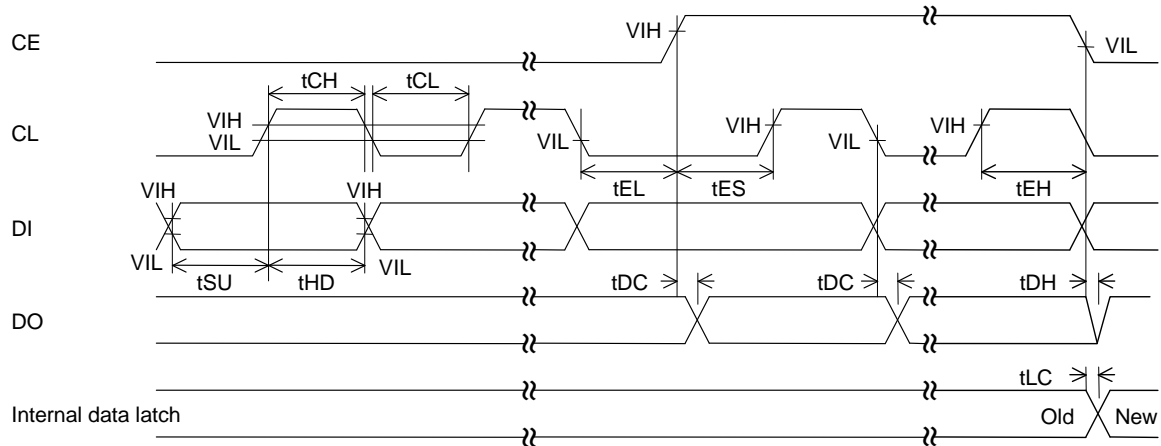

<< When CL stops at the "L" level >>

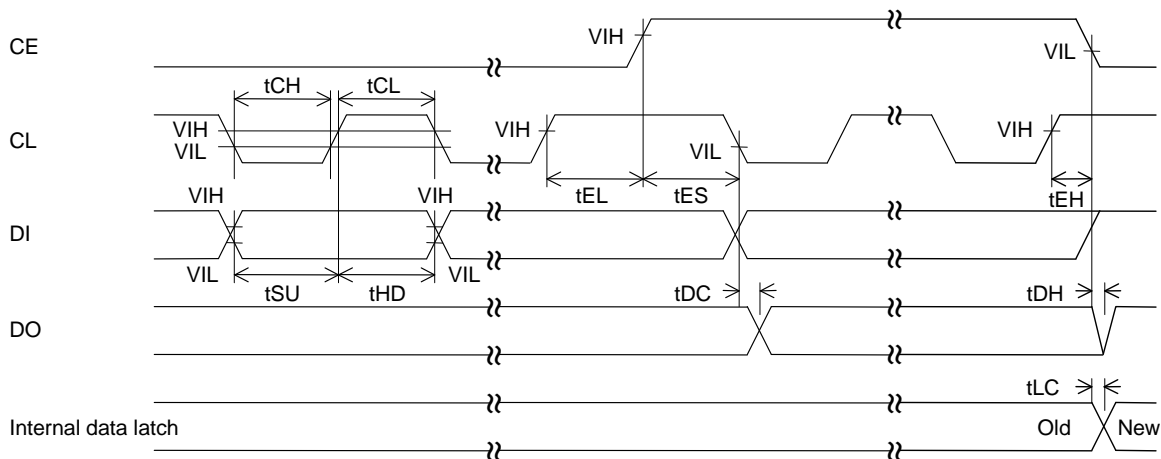

<< When CL stops at the "H" level >>

Parameter	Symbol	Pin	Conditions	Min	Typ	Max	Unit
Data setup time	t_{SU}	DI, CL		0.75			μs
Data hold time	t_{HD}	DI, CL		0.75			μs
Clock "L" level time	t_{CL}	CL		0.75			μs
Clock "H" level time	t_{CH}	CL		0.75			μs
CE wait time	t_{EL}	CE, CL		0.75			μs
CE setup time	t_{ES}	CE, CL		0.75			μs
CE hold time	t_{EH}	CE, CL		0.75			μs
Data latch change time	t_{LC}					0.75	μs
Data output time	t_{DC}	DO, CL	Differs depending on the pull-up resistance and substrate capacity			0.35	μs
	t_{DH}	DO, CE					

LV23200T

Block Diagram

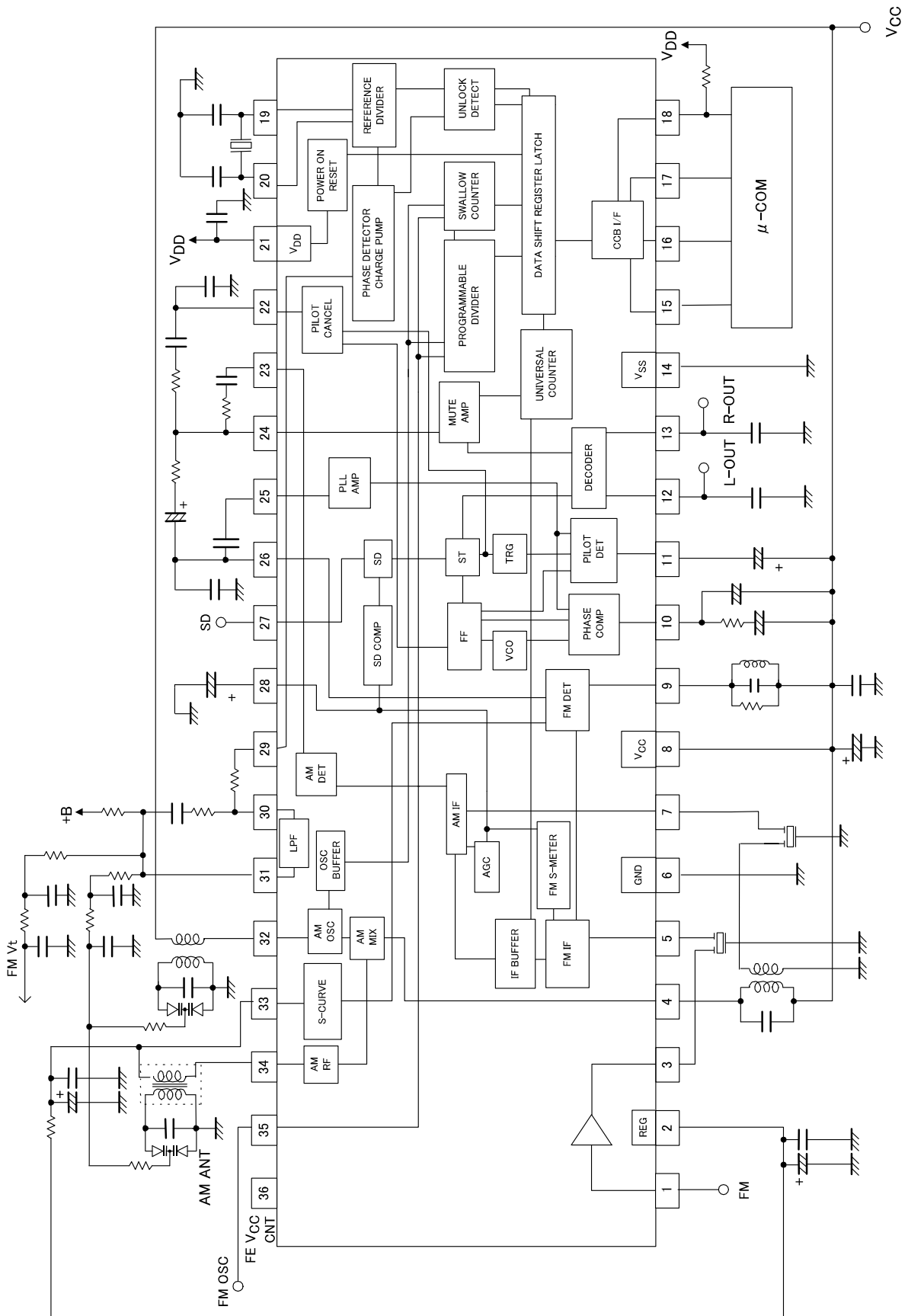

ON Semiconductor and the ON logo are registered trademarks of Semiconductor Components Industries, LLC (SCILLC). SCILLC owns the rights to a number of patents, trademarks, copyrights, trade secrets, and other intellectual property. A listing of SCILLC's product/patent coverage may be accessed at www.onsemi.com/site/pdf/Patent-Marking.pdf. SCILLC reserves the right to make changes without further notice to any products herein. SCILLC makes no warranty, representation or guarantee regarding the suitability of its products for any particular purpose, nor does SCILLC assume any liability arising out of the application or use of any product or circuit, and specifically disclaims any and all liability, including without limitation special, consequential or incidental damages. "Typical" parameters which may be provided in SCILLC data sheets and/or specifications can and do vary in different applications and actual performance may vary over time. All operating parameters, including "Typicals" must be validated for each customer application by customer's technical experts. SCILLC does not convey any license under its patent rights nor the rights of others. SCILLC products are not designed, intended, or authorized for use as components in systems intended for surgical implant into the body, or other applications intended to support or sustain life, or for any other application in which the failure of the SCILLC product could create a situation where personal injury or death may occur. Should Buyer purchase or use SCILLC products for any such unintended or unauthorized application, Buyer shall indemnify and hold SCILLC and its officers, employees, subsidiaries, affiliates, and distributors harmless against all claims, costs, damages, and expenses, and reasonable attorney fees arising out of, directly or indirectly, any claim of personal injury or death associated with such unintended or unauthorized use, even if such claim alleges that SCILLC was negligent regarding the design or manufacture of the part. SCILLC is an Equal Opportunity/Affirmative Action Employer. This literature is subject to all applicable copyright laws and is not for resale in any manner.