



ON Semiconductor®

<http://onsemi.com>

LA1844MC

Monolithic Linear IC

Single-chip Tuner IC for Home Stereo

Overview

The LA1844MC is designed for use in mini systems and is a single-chip tuner IC that provides electronic tuning functions using SD/IF-count technique. It incorporates a pilot canceler and an adjustment-free MUX VCO circuit, thus allows additional parts to be reduced.

Features

- Integrated MPX VCO (ceramic resonators are no longer required.)
- Built-in adjacent channel interference rejection function (114kHz, 190kHz)
- Supports both SD and IF-count techniques
- Both FM SD sensitivity and bandwidth can be set
- Pilot canceler built in.
- Package : MFP24SJ(300mil)

Functions

- AM : RF amplifier, mixer, oscillator, IF amplifier, detector, AGC, SD, oscillator buffer, IF buffer, stereo IF output, AGC time constant switch
- FM IF : IF amplifier, quadrature detector, S-meter, SD (signal detection), S-curve detection, IF buffer output
- MPX : PLL stereo decoder, stereo display, forced monaural, VCO stop, audio muting, adjacent channel interference rejection function, pilot canceler

LA1844MC

Specifications

Maximum Ratings at $T_a = 25^\circ\text{C}$

Parameter	Symbol	Conditions	Ratings	Unit
Maximum supply voltage	V_{CC} max		9	V
Allowable power dissipation	P_d max	$T_a \leq 45^\circ\text{C}$	400	mW
		$T_a \leq 80^\circ\text{C}$	260	mW
Operating temperature	T_{opr}		-20 to +80	$^\circ\text{C}$
Storage temperature	T_{stg}		-20 to +150	$^\circ\text{C}$

Stresses exceeding Maximum Ratings may damage the device. Maximum Ratings are stress ratings only. Functional operation above the Recommended Operating Conditions is not implied. Extended exposure to stresses above the Recommended Operating Conditions may affect device reliability.

Operating Conditions at $T_a = 25^\circ\text{C}$

Parameter	Symbol	Conditions	Ratings	Unit
Recommended supply voltage	V_{CC}		5	V
Operating supply voltage range	V_{CC} op		4.3 to 8.0	V

Electrical Characteristics at $T_a = 25^\circ\text{C}$

FM Mono Characteristics at $f_C = 10.7\text{MHz}$, $V_{CC} = 5\text{V}$

Parameter	Symbol	Conditions	Ratings			Unit
			min	typ	max	
Current drain	I_{CCO-FM}	With no input signal	18	28	38	mA
Demodulator output	V_{OFM}	100dB μ , 100% modulation, $f_m = 1\text{kHz}$	210	330	420	mVrms
Total harmonic distortion	THD_{FM} mono	100dB μ , 100% modulation, $f_m = 1\text{kHz}$		0.35	1.5	%
Signal-to-noise ratio	S/N_{FM}	100dB μ , 100% modulation, $f_m = 1\text{kHz}$	73	80		dB
AM rejection ratio	AMR	100dB μ , AM 30% modulation, $f_m = 1\text{kHz}$	47	65		dB
3dB sensitivity	V_i -limit	100dB μ , 100% modulation, $f_m = 1\text{kHz}$ output reference, -3dB input		32	40	dB μ
SD sensitivity	LED Sens	0% modulation	37	47	57	dB μ
IF counter buffer output	$V_{IFBuff-FM}$	100dB μ	200	275	400	mVrms
Mute attenuation	Mute-Att	100dB μ , 100% modulation, $f_m = 1\text{kHz}$		76		dB

FM Stereo Characteristics at $f_C = 10.7\text{MHz}$, 100dB μ , $V_{CC} = 5\text{V}$

Parameter	Symbol	Conditions	Ratings			Unit
			min	typ	max	
Separation	Sep	L+R = 90%, Pilot = 10%, $f_m = 1\text{kHz}$	30	42		dB
Stereo on level	ST_{ON}	Pilot input	1.5	3.5	5.5	%
Total harmonic distortion	THD -main	Pilot input		0.45	1.5	%
Adjacent channel rejection ratio 1	BR1	$f_s = 113\text{kHz}$, $V_s = 90\%$, pilot = 10% : The left - right modulation, demodulated output		36		dB
Adjacent channel rejection ratio 2	BR2	$f_s = 189\text{kHz}$, $V_s = 90\%$, pilot = 10% : The left - right modulation, demodulated output		41		dB
Carrier leak	CL	L+R = 90%, pilot = 10% reference, pilot = 10% output	38	44		dB

AM Characteristics at $f_C = 1000\text{kHz}$, $V_{CC} = 5\text{V}$

Parameter	Symbol	Conditions	Ratings			Unit
			min	typ	max	
Current drain	I_{CCO-AM}	With no input signal	11	22	33	mA
Detector output	V_{OAM1}	23dB μ , 30% modulation, $f_m = 1\text{kHz}$	40	80	160	mVrms
	V_{OAM2}	80dB μ , 30% modulation, $f_m = 1\text{kHz}$	90	160	230	mVrms
Signal-to-noise ratio	S/N_{AM1}	23dB μ , 30% modulation, $f_m = 1\text{kHz}$	17	23		dB
	S/N_{AM2}	80dB μ , 30% modulation, $f_m = 1\text{kHz}$	48	54		dB
Total harmonic distortion	THD_{AM1}	80dB μ , 30% modulation, $f_m = 1\text{kHz}$		0.4	1.1	%
	THD_{AM2}	107dB μ , 30% modulation, $f_m = 1\text{kHz}$		0.5	1.3	%
SD sensitivity	SD-Sens	0% modulation	11	21	31	dB μ
Local oscillator buffer output	V_{OSC-AM}	With no input signal	100	140	200	mVrms
IF counter buffer output	$V_{IFBuff-AM}$	23dB μ	140	285	400	mVrms

Package Dimensions

unit : mm

3419

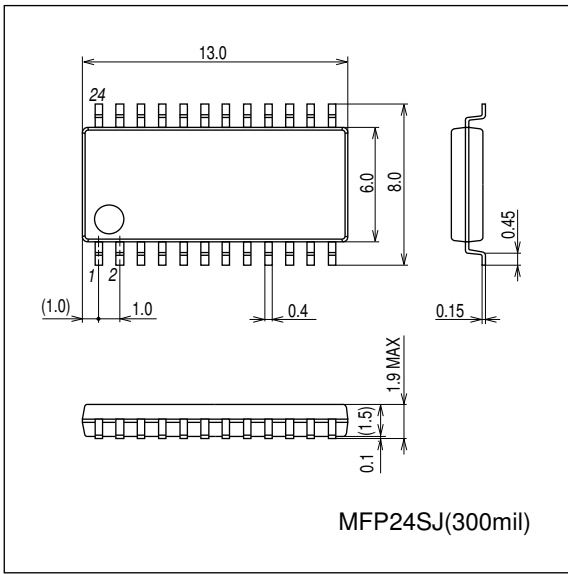

LA1844MC

Block Diagram

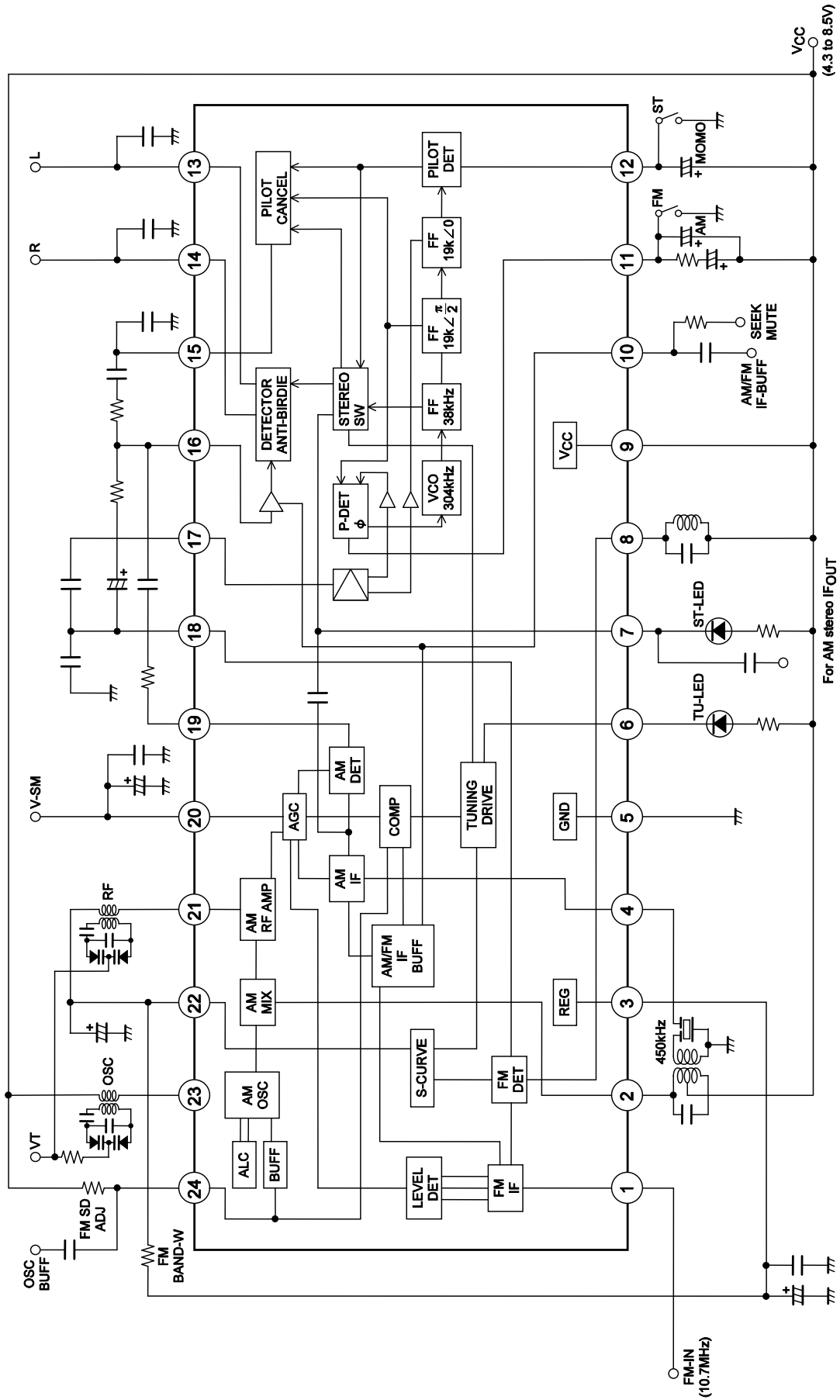

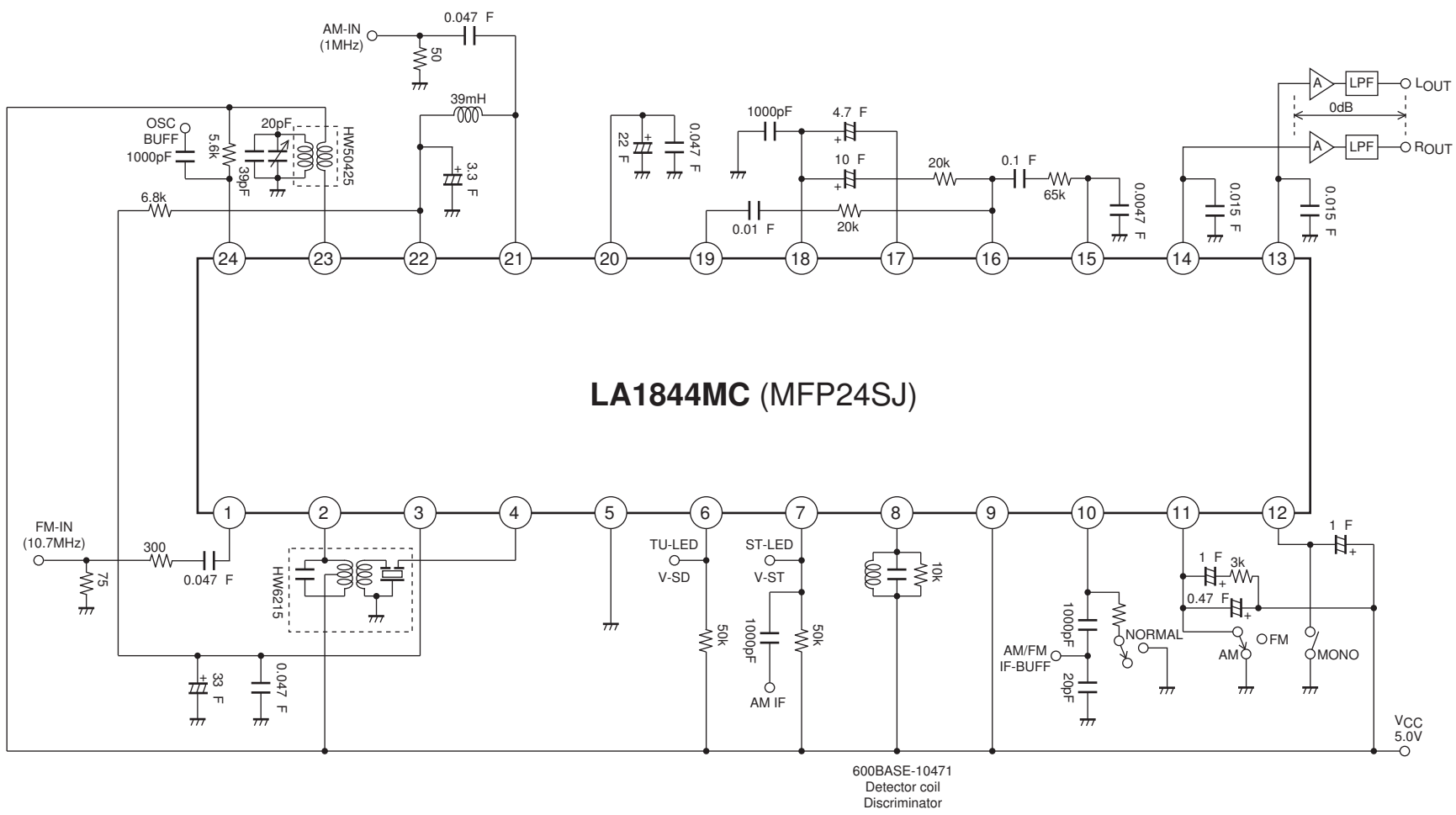

600BASE-10471
Detector coil
Discriminator

LA1844MC

Pin Functions

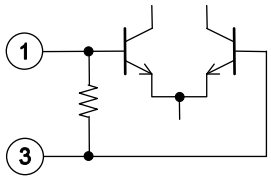
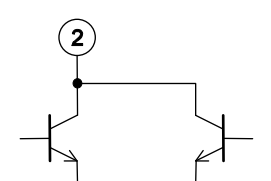
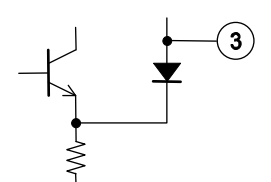
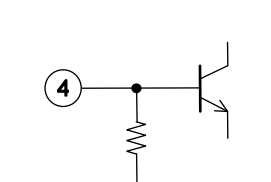
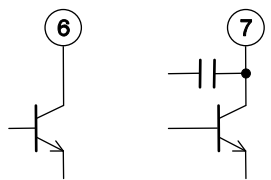
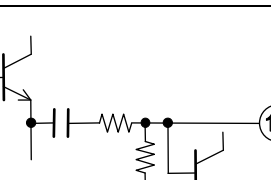
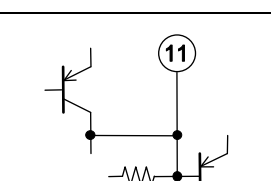
Pin No.	Function	Pin voltage (V)	Equivalent circuit	Notes
1	FM IF input	Vreg		Input impedance $R_i = 330\Omega$
2	AM mixer output	V_{CC}		Connect the mixer coil between this pin and V_{CC}
3	REG	2.1		$V_{reg} = 2.4V$
4	AM IF input	Vreg		Input impedance $R_i = 2k\Omega$
5	GND	0		
6	Tu-LED	V_{CC}		Active low Open collector
7	ST-LED / AM-IF output			
8	FM detector	V_{CC}		The 600BEAS-10471 (Toko Mfg. Co., Ltd.) is recommended for detector coil.
9	VCC	5.0		
10	AM / FM IF counter output, output control switch, mute switch	0		$V_{10} \leq 0.5V$: Reception state (Normal) $1.4V \leq V_{10} \leq 2.2V$: Muting on (Mute) $V_{10} \geq 3.5V$: IF counter output and muting on (Seek)
11	Phase comparator low-pass filter (AM/FM switching)	$V_{CC}-1.0$		The device operates in AM mode when a current of over $200\mu A$ flows from pin 12.

Continued on next page.

LA1844MC

Continued from preceding page.

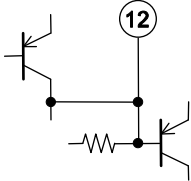
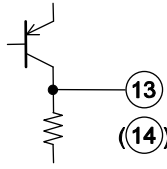
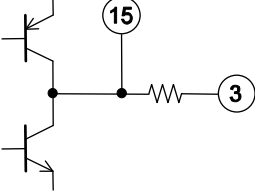
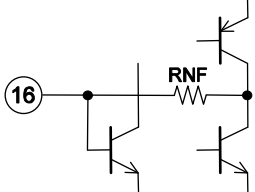
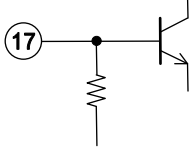
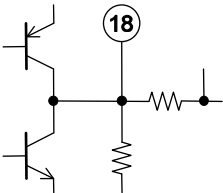
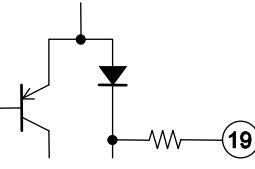
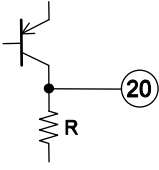
Pin No.	Function	Pin voltage (V)	Equivalent circuit	Notes
12	Pilot detector low-pass filter (Forced mono) (VCO stop)	$V_{CC}-1.0$		The device is forced to monaural when a current of over $50\mu A$ flows from this pin. The VCO is stopped when a current of over $200\mu A$ flows from this pin.
13 14	L outputs R outputs	3.2		Output impedance $R_O = 3.3k\Omega$
15	Pilot canceler output	Vreg		
16	Decoder input	Vreg		Inverting input pin $R_{NF} = 20k\Omega$
17	PLL input	Vreg		Input impedance $R_i = 20k\Omega$
18	FM demodulator output	$V_{reg}+0.7$		Output impedance $R_O = 2.3k\Omega$ The channel separation can be adjusted with an external capacitor connected between this pin and ground.
19	AM detector output	0 (FM) 1.5 (AM)		Output impedance $R_O = 3.3k\Omega$
20	S meter, AM AGC	0.2 (FM) 0.9 (AM)		The resistance of the built-in resistor R is $13.9k\Omega$ The SD response during seek operation is determined with the external capacitor connected to this pin.

Continued on next page.

LA1844MC

Continued from preceding page.

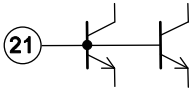
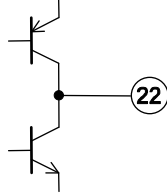
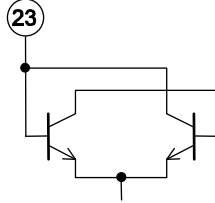
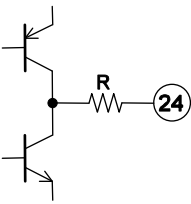
Pin No.	Function	Pin voltage (V)	Equivalent circuit	Notes
21	AM RF input	Vreg		Must be used at the same potential as pin 22
22	AFC	Vreg		The FM SD bandwidth can be adjusted with the external resistor connected between this pin and pin 3 (REG)
23	OSC	V _{CC}		Connect the oscillator coil between this pin and pin 9 (V _{CC}) Note: Impedance of the secondary oscillator coil must be 5kΩ or higher.
24	Oscillator buffer output, FM SD sensitivity adjustment	V _{CC} -1.4		The FM SD sensitivity can be adjusted with an external resistor connected to this pin. Output impedance R _O = 200Ω Note: Resistance of the external resistor connected to the pin 24 must be 3.3kΩ or higher.

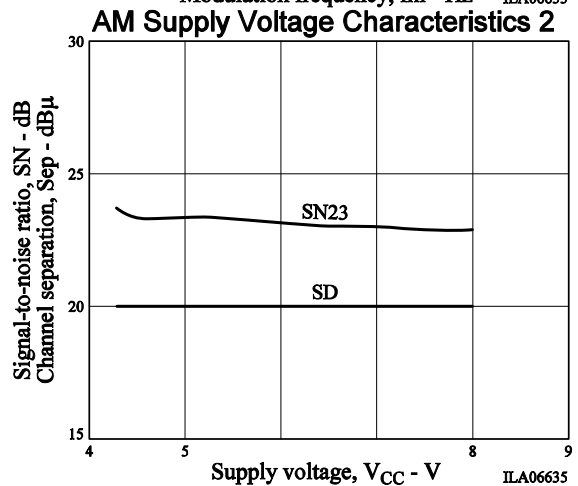
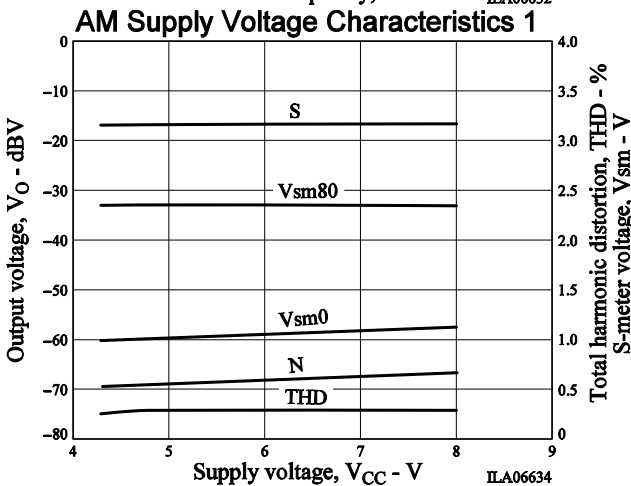
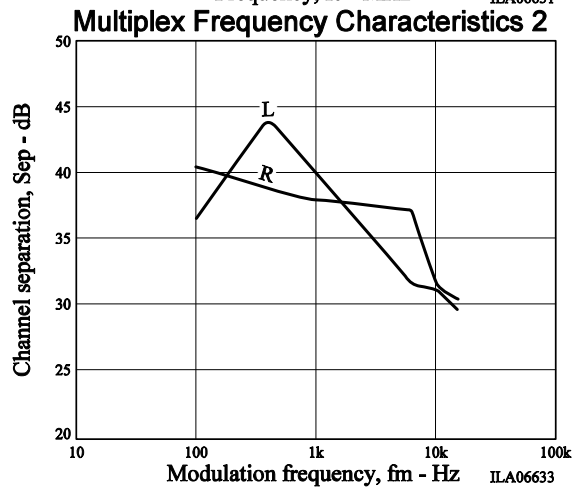
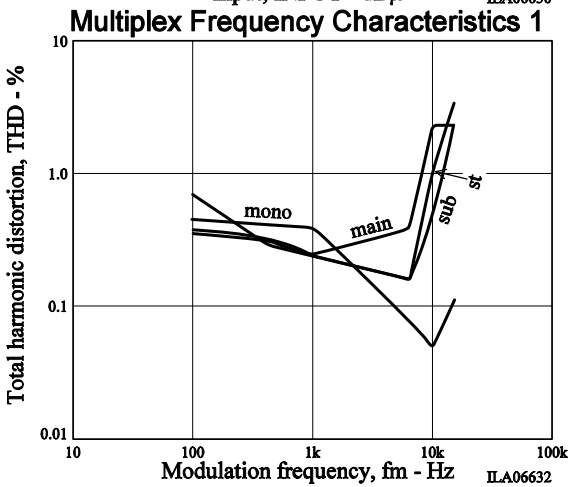
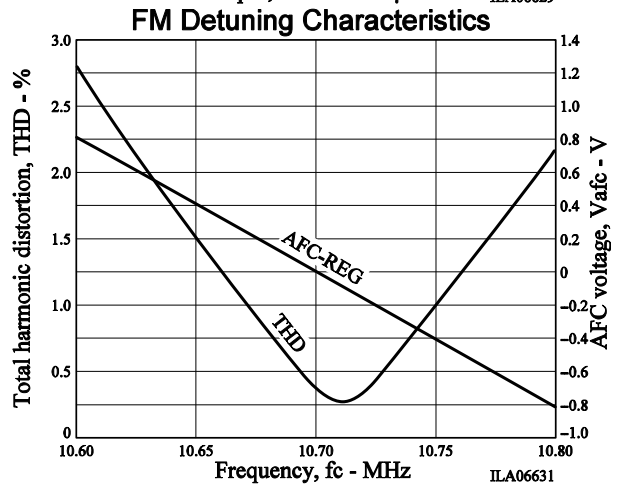
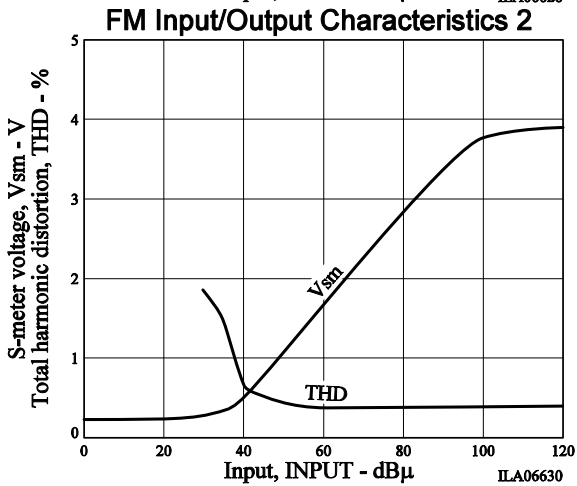
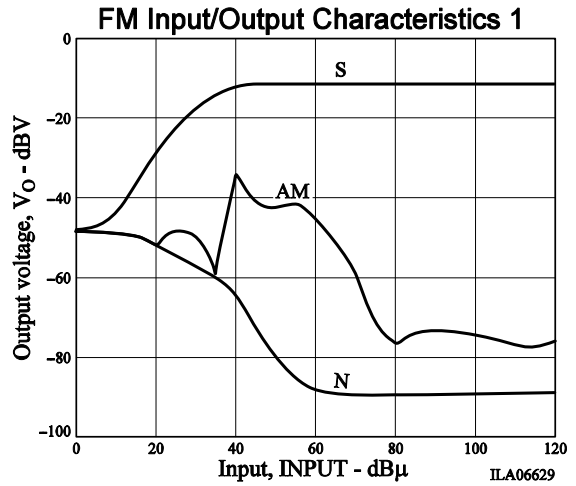
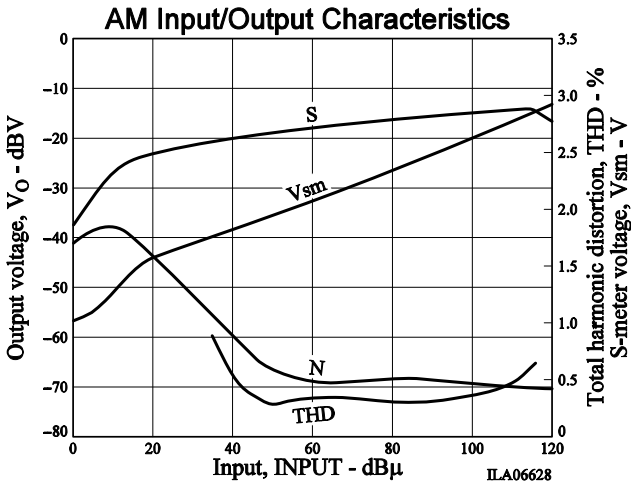

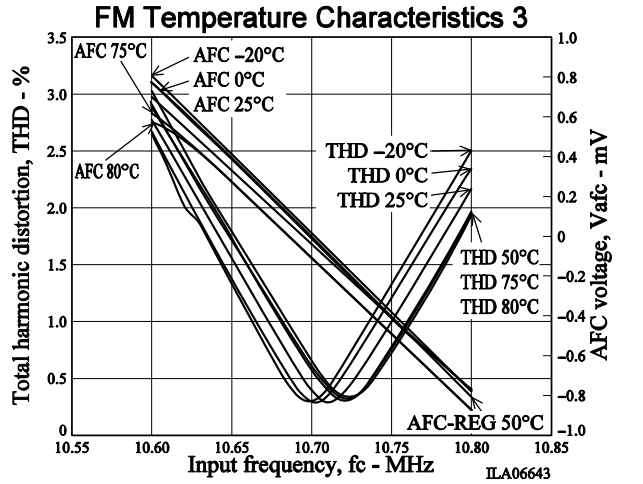
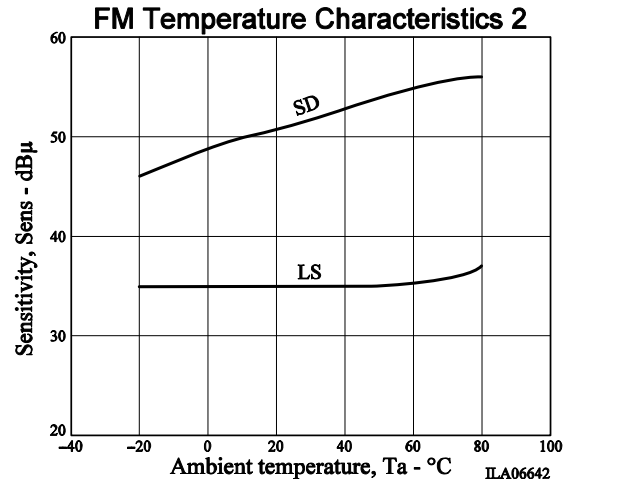
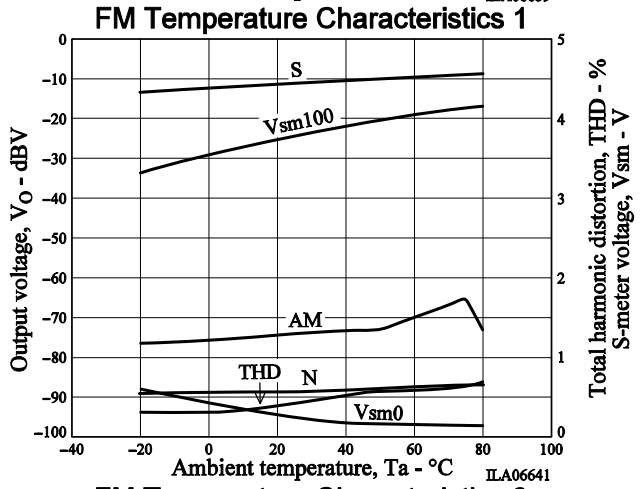
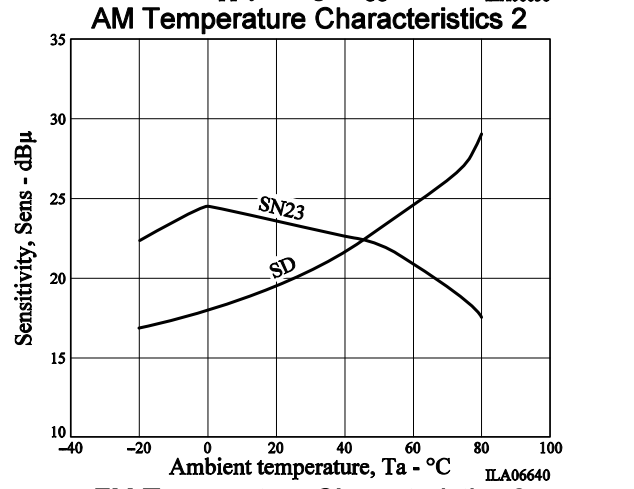
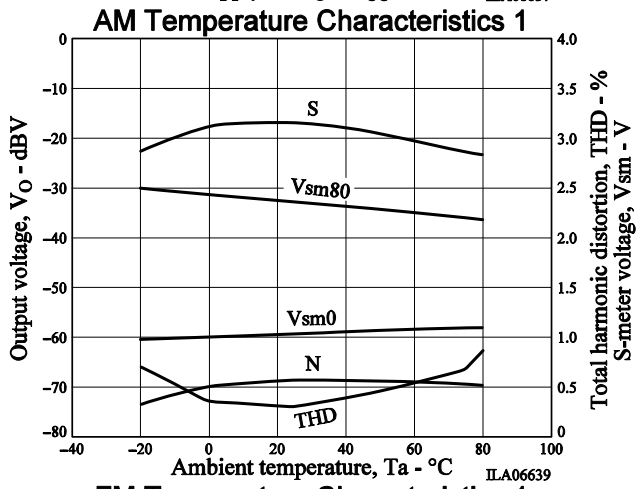
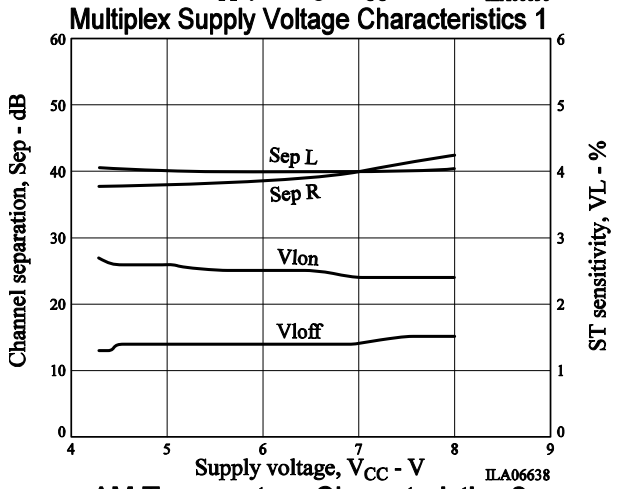
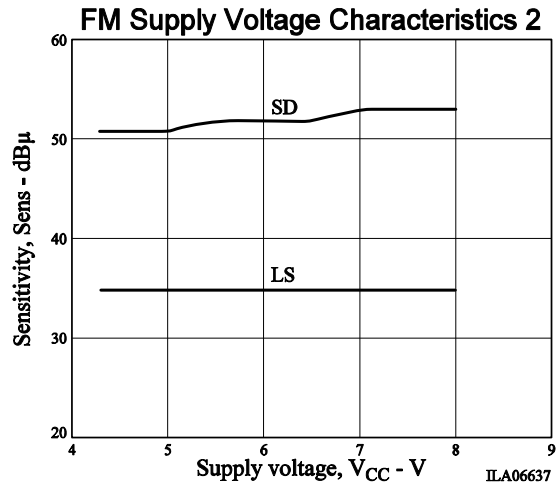
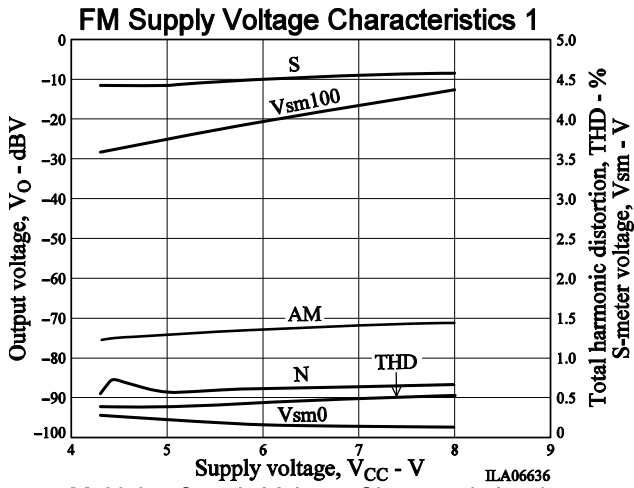

Multiplex Temperature Characteristics 1

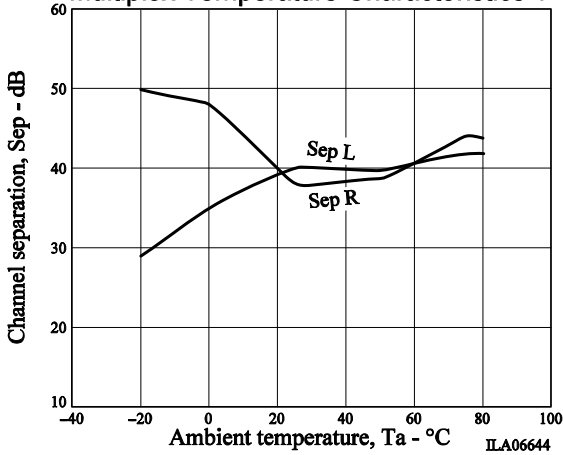

Multiplex Temperature Characteristics 2

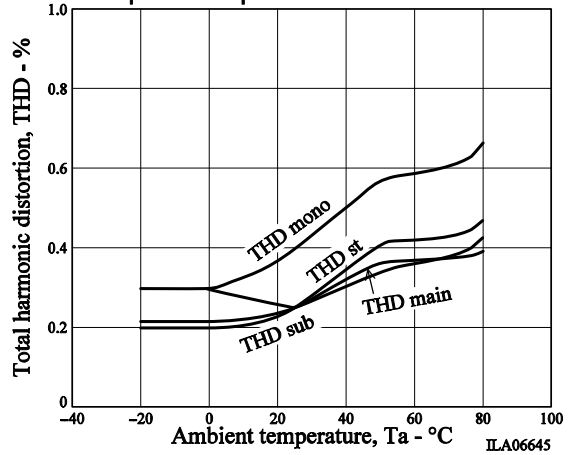

Multiplex Temperature Characteristics 3

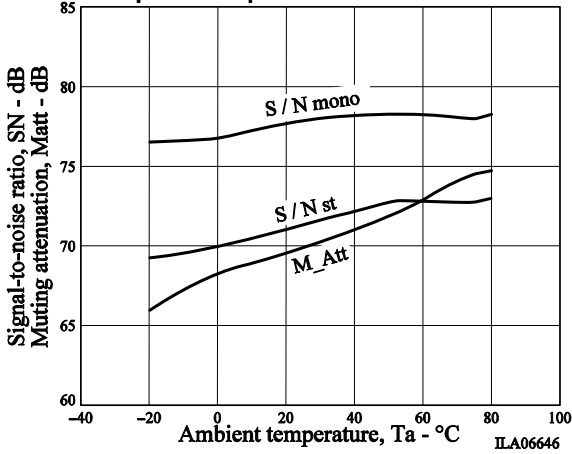

Multiplex Temperature Characteristics 4

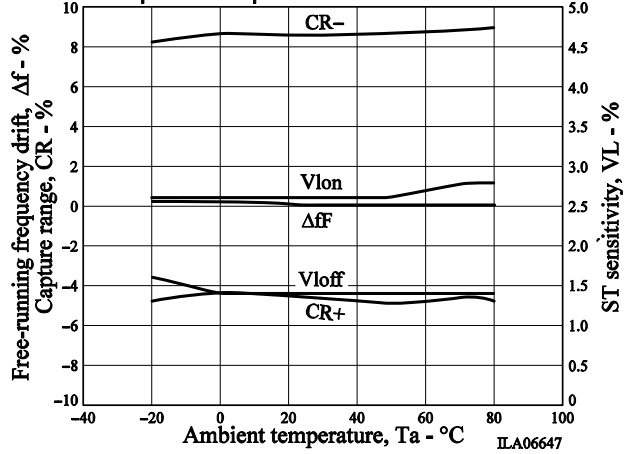

ON Semiconductor and the ON logo are registered trademarks of Semiconductor Components Industries, LLC (SCILLC). SCILLC owns the rights to a number of patents, trademarks, copyrights, trade secrets, and other intellectual property. A listing of SCILLC's product/patent coverage may be accessed at www.onsemi.com/site/pdf/Patent-Marking.pdf. SCILLC reserves the right to make changes without further notice to any products herein. SCILLC makes no warranty, representation or guarantee regarding the suitability of its products for any particular purpose, nor does SCILLC assume any liability arising out of the application or use of any product or circuit, and specifically disclaims any and all liability, including without limitation special, consequential or incidental damages. "Typical" parameters which may be provided in SCILLC data sheets and/or specifications can and do vary in different applications and actual performance may vary over time. All operating parameters, including "Typicals" must be validated for each customer application by customer's technical experts. SCILLC does not convey any license under its patent rights nor the rights of others. SCILLC products are not designed, intended, or authorized for use as components in systems intended for surgical implant into the body, or other applications intended to support or sustain life, or for any other application in which the failure of the SCILLC product could create a situation where personal injury or death may occur. Should Buyer purchase or use SCILLC products for any such unintended or unauthorized application, Buyer shall indemnify and hold SCILLC and its officers, employees, subsidiaries, affiliates, and distributors harmless against all claims, costs, damages, and expenses, and reasonable attorney fees arising out of, directly or indirectly, any claim of personal injury or death associated with such unintended or unauthorized use, even if such claim alleges that SCILLC was negligent regarding the design or manufacture of the part. SCILLC is an Equal Opportunity/Affirmative Action Employer. This literature is subject to all applicable copyright laws and is not for resale in any manner.