



# SANYO Semiconductors

## DATA SHEET

# LA79500E

Monolithic Linear IC  
For TV  
6-input, 3-output Switch

### Overview

This LA79500E is a 6-input, 3-output switch for TV.

### Functions

- Composite 6 inputs with 3 outputs
- Component 2 inputs with 2 outputs
- Audio 8 inputs with 3 outputs (L/R)
- Serial control with I<sup>2</sup>C bus
- General purpose I/O
- Acceptance from Y/C comb filter output
- S1, S2 protocol interface
- Y/C MIX circuit
- All video and audio output Gains are selectable by a single bit as 0 or 6dB.
- Sync-tip clamps include a simple signal detector readable over I<sup>2</sup>C bus.

### Specifications

#### Maximum Ratings at Ta = 25°C

Parameter	Symbol	Conditions	Ratings	Unit
Maximum supply voltage	V <sub>CC</sub> max		13	V
Allowable current electric power	Pd max	* Mounted on a board.	1600	mW
Operating temperature	Topr		-25 to +75	°C
Storage temperature	Tstg		-55 to +150	°C

\* Mounted on a board : 114.3×76.1×1.6mm<sup>3</sup>, glass epoxy resin.

#### Operating Conditions at Ta = 25°C

Parameter	Symbol	Conditions	Ratings	Unit
Recommending supply voltage	V <sub>CC</sub>		12	V
Operating supply voltage	V <sub>CC</sub> op		11.4 to 12.7	V

■ Any and all SANYO Semiconductor products described or contained herein do not have specifications that can handle applications that require extremely high levels of reliability, such as life-support systems, aircraft's control systems, or other applications whose failure can be reasonably expected to result in serious physical and/or material damage. Consult with your SANYO Semiconductor representative nearest you before using any SANYO Semiconductor products described or contained herein in such applications.

■ SANYO Semiconductor assumes no responsibility for equipment failures that result from using products at values that exceed, even momentarily, rated values (such as maximum ratings, operating condition ranges, or other parameters) listed in products specifications of any and all SANYO Semiconductor products described or contained herein.

**SANYO Semiconductor Co., Ltd.**

TOKYO OFFICE Tokyo Bldg., 1-10, 1 Chome, Ueno, Taito-ku, TOKYO, 110-8534 JAPAN

# LA79500E

## Electrical Characteristics/Operating Conditions at $T_a = 25^\circ\text{C}$ , $V_{CC} = 12\text{V}$

Parameter	Symbol	Conditions	Ratings			Unit
			min	typ	max	
Current consumption	$I_{CC}$	No signal, No load	67	90	113	mA
[Video system]						
Frequency response characteristics	frv	100kHz/7MHz	-1.0	0	1.0	dB
Maximum input level	Ddv	$f = 100\text{kHz}$ , output THD = 1% input	1.4	1.6		Vp-p
Voltage gain 1	GVv1	6dB select	5.9	6.4	6.9	dB
Voltage gain 2	GVv2	0dB select	0.0	0.4	0.9	dB
Cross talk	Vctv	$f = 3.58\text{MHz}$		-60	-55	dB
[Audio system]						
Voltage gain 1	GVa1	6dB select	5.9	6.4	6.9	dB
Voltage gain 2	GVa2	0dB select	0.0	0.4	0.9	dB
Frequency response characteristics	Fra	100Hz/20kHz	-1.0	0	1.0	dB
Total harmonic distortion	THD	$f = 1\text{kHz}$ , 2.2Vp-p input		0.03	0.05	%
Maximum input level	Dda	$f = 1\text{kHz}$ , output THD = 0.3% input	2.3	2.5		Vrms
Cross talk	Vcta	$f = 1\text{kHz}$ , 1Vp-p input		-90	-80	dB
Supply Ripple rejection ratio	SRrr	$f = 100\text{Hz}$ , 0.3Vp-p applied to $V_{CC}$		-55	-40	dB
S/N ratio	S/Na	$f = 1\text{kHz}$ , 1Vrms input		-100	-90	dB
[Logic system]						
High level input voltage	ViH		3.5		5.0	V
Low level input voltage	ViL		0		1.5	V
Low level output voltage	VoL	SDA 3mA current supplied	0		0.4	V
High level input current	IiH	$V_{IH} = 4.5\text{V}$	0		10	$\mu\text{A}$
Low level input current	IiL	$V_{IL} = 0.4\text{V}$	0		10	$\mu\text{A}$
Maximum clock frequency	fscL		0		100	kHz
Minimum waiting time for data change	tBUF		4.7			$\mu\text{s}$
Minimum waiting time for data transfer start	tHD:STA		4.0			$\mu\text{s}$
Low level clock Pulse width	tLOW		4.7			$\mu\text{s}$
High level clock pulse width	tHIGH		4.0			$\mu\text{s}$
Minimum waiting time for start preparation	tSU:STA		4.7			$\mu\text{s}$
Minimum data hold time	tHD:DAT		0			$\mu\text{s}$
Minimum data preparation time	tSU:DAT		250			ns
Rise time	tR				1	$\mu\text{s}$
Fall time	tF				300	ns
Minimum waiting time for stop preparation	tSU:STO		4.7			$\mu\text{s}$
GPIO1/2/3/4/5/6 (Pin5/13/27/33/55/63)						
High level input voltage	GPIH		3.5			V
Low level input voltage	GPI L				1.5	V
High level output voltage	GPOH	50 $\mu\text{A}$ current loaded	4.0			V
Low level output voltage	GPOL	1mA current supplied			1.0	V
DC_OUT (Pin67)						
High level output voltage	DCOH	DC_OUT (BUS Write) 11 $R_L = 100\text{k}\Omega$	4.0	4.5		V
Middle level output voltage	DCOM	DC_OUT (BUS Write) 10 $R_L = 100\text{k}\Omega$	1.4	1.9	2.4	V
Low level output voltage	DCOL	DC_OUT (BUS Write) 01/00 $R_L = 100\text{k}\Omega$			0.5	V
DC_IN (Pin66)						
High level input voltage	DCIH	DC_IN (BUS read) 10	3.0			V
Middle level input voltage	DCIM	DC_IN (BUS read) 01	1.5	1.9	2.3	V
Low level input voltage	DCIL	DC_IN (BUS read) 00			1.0	V

# LA79500E

## Terminal Voltage/ Input Impedance

Parameter	Symbol	Conditions	Ratings			Unit
			min	typ	max	
Video signal inputs terminal voltage (Pin6/14/34/71/75/78)	CVYIV		2.0	2.5	3.0	V
Video signal outputs terminal voltage (Pin46/56/64)	CVYOV		2.0	2.5	3.0	V
Y signal inputs terminal voltage (Pin8/16/21/28/36/80/65)	YIV		2.0	2.5	3.0	V
Y/V signal outputs terminal voltage (Pin54/62)	YOV		2.0	2.5	3.0	V
C signal inputs terminal voltage (Pin2/10/18/38/68)	CIV		2.3	2.8	3.3	V
C signal outputs terminal voltage (Pin52/60)	COV		2.3	2.8	3.3	V
C signal inputs terminal impedance (Pin2/10/18/38/68)	Clz		8.0	10.0	12.0	k $\Omega$
Pb/Pr signal inputs terminal voltage (Pin23/25/30/32)	PbrIV		2.0	2.5	3.0	V
Pb/Pr signal outputs terminal voltage (Pin49/50/57/58)	PbrOV		1.9	2.4	2.9	V
Audio signal inputs terminal voltage (Pin1/7/9/15/17/22/24/29/31/35/37/70/72/74/76/79)	AIV		5.3	5.8	6.3	V
Audio signal outputs terminal voltage (Pin45/47/51/53/59/61)	AOV		4.7	5.2	5.7	V
Audio signal inputs terminal impedance (Pin1/7/9/15/17/22/24/29/31/35/37/70/72/74/76/79)	Alz		40.0	50.0	60.0	k $\Omega$

# LA79500E

## Package Dimensions

unit : mm

3174A

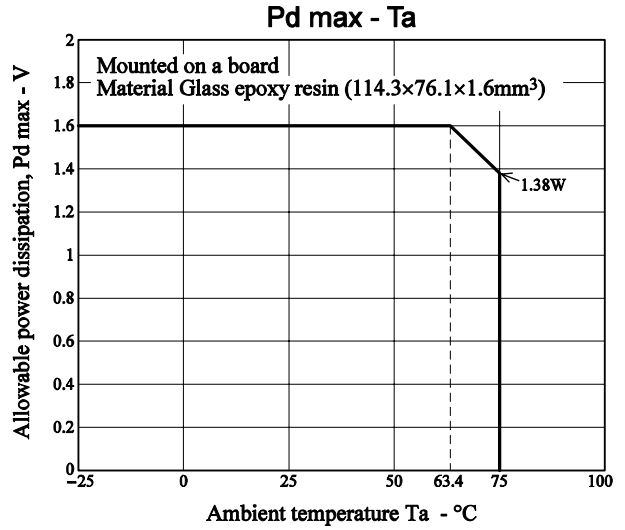
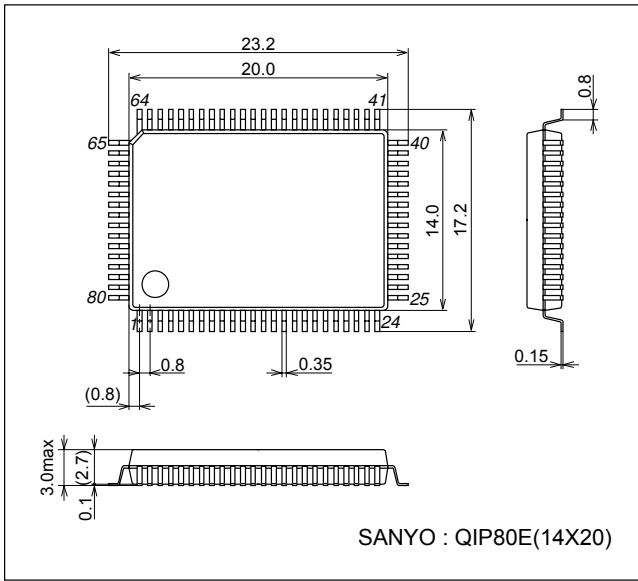

## Block Diagram

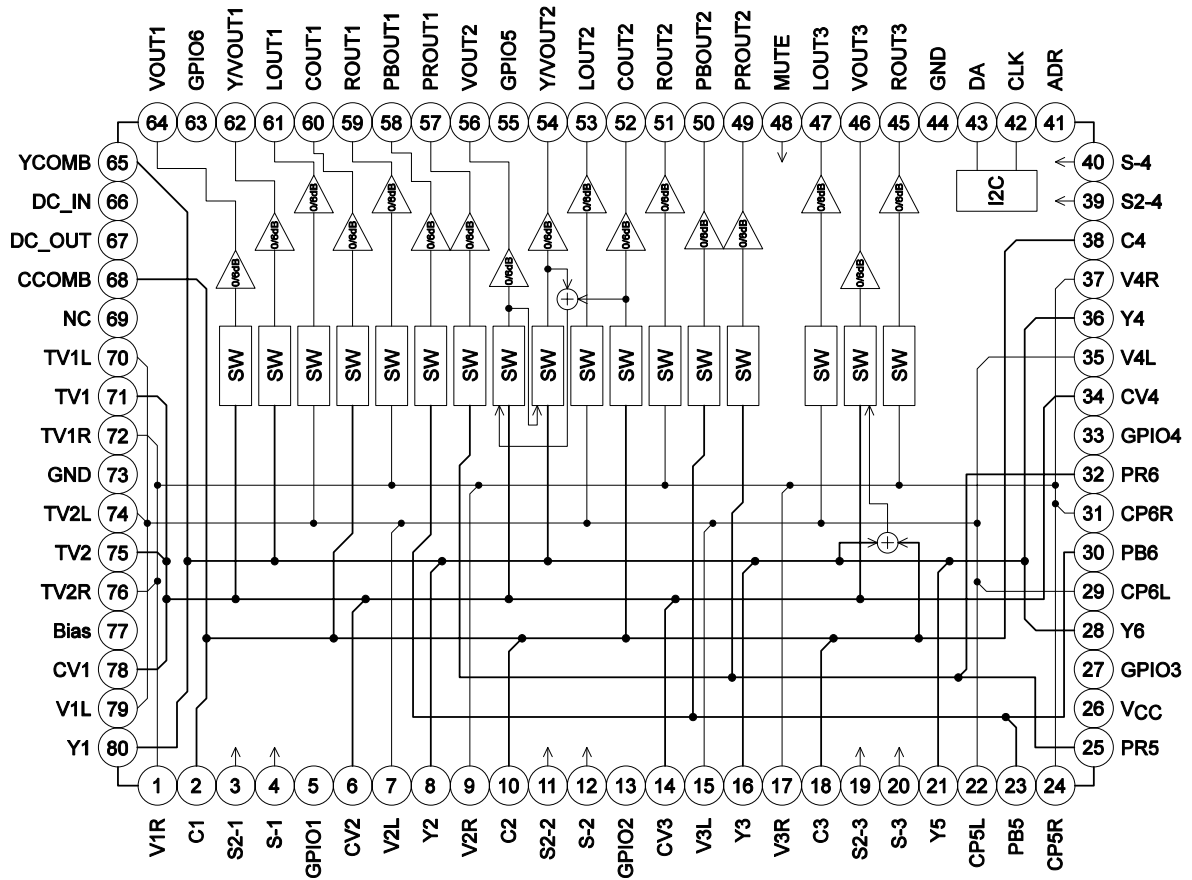

# LA79500E

## Pin Description

Pin No.	Symbol	Pin Voltage (V)	Description	Equivalent circuit
71 75 78 6 14 34	TV1 TV2 CV1 CV2 CV3 CV4	2.5	Video signal inputs. Input composite video signals.	
80 8 16 36 21 28	Y1 Y2 Y3 Y4 Y5 Y6	2.5	Y/C separation signal inputs. Input luminance signals.	
2 10 18 38	C1 C2 C3 C4	2.8	Y/C separation signal inputs. Input chrominance signals.	
70, 72 74, 76 79, 1 7, 9 15, 17 35, 37 22, 24 29, 31	TV1L, TV1R TV2L, TV2R V1L, V1R V2L, V2R V3L, V3R V4L, V4R CP5L, CP5R CP6L, CP6R	5.8	Audio signal inputs.	
25 23 32 30	PR5 PB5 PR6 PB6	2.5	Component PB/PR inputs.	
64 56 46	VOUT1 VOUT2 VOUT3	2.5	Video signal outputs. Output composite video signals.	

Continued on next page.

# LA79500E

Continued from preceding page.

Pin No.	Symbol	Pin Voltage (V)	Description	Equivalent circuit
62 54	Y/VOUT1 Y/VOUT2	2.5	Video signal outputs. Either composite video signal output or luminance signal output can be selected by I <sup>2</sup> C bus control.	
60 52	COUT1 COUT2	2.8	Video signal outputs. Output chrominance signals.	
61 53 47 59 51 45	LOUT1 LOUT2 LOUT3 ROUT1 ROUT2 ROUT3	5.2	Audio signal outputs.	
4 12 20 40	S-1 S-2 S-3 S-4		Composite video/S selector. The detection results are written to the status register. S signal at 3.5V or less. Composite video signal at 3.5V or more. This pin is pulled up to 5V by a 100kΩ resistor, so the composite video signal is selected when open.	
3 11 19 39	S2-1 S2-2 S2-3 S2-4		Detects the S2-compatible DC superimposed onto the C signal. 4:3 video signal at 1.3V or less. 4:3 letter-box signal at 1.3V or more to 2.5V or less. 16:9 picture squeezed signal at 2.5V or more. This pin is pulled down to GND by a 100kΩ resistor, so the 4:3 video signal is selected when open.	
57 58 49 50	PROUT1 PBOUT1 PROUT2 PBOUT2	2.4	Component PB/PR outputs.	

Continued on next page.

# LA79500E

Continued from preceding page.

Pin No.	Symbol	Pin Voltage (V)	Description	Equivalent circuit
5 13 27 33 55 63	GPIO1 GPIO2 GPIO3 GPIO4 GPIO5 GPIO6		General purpose I/O.	
65	YCOMB	2.5	The YCOMB pin inputs the signal obtained by Y/C separating the VOUT1 pin output.	
68	CCOMB	2.8	The CCOMB pin inputs the signal obtained by Y/C separating the VOUT1 pin output.	
41	ADR		Selects the slave address for the I <sup>2</sup> C bus. 90H at 1.5V or less. 92H at 2.5V or more. 90H when open.	
43	DATA		I <sup>2</sup> C bus signal input V <sub>IL</sub> max = 1.5V V <sub>IH</sub> min = 3.0V V <sub>OL</sub> max = 0.4V	
42	CLK		I <sup>2</sup> C bus signal input V <sub>IL</sub> max = 1.5V V <sub>IH</sub> min = 3.0V	

Continued on next page.

# LA79500E

Continued from preceding page.

Pin No.	Symbol	Pin Voltage (V)	Description	Equivalent circuit
77	BIAS	10.2	Internal reference bias. Connect to GND via a capacitor.	
66	DC_IN		Detection Pin of DC input 1.3V or less : 00 1.3V or more to 2.5V or less : 01 2.5V or more : 10 This pin is pulled down to GND by a 100kΩ resistor.	
67	DC_OUT		Outputs the S2-compatible DC. Control is performed by the I <sup>2</sup> C bus. S2 protocol output impedance of 10±3Kohm is realized by attaching external resistance of 4.7kohm. DC_OUT (bus)    Output DC 00                0V 01                0V 10                1.9V 11                4.5V	
48	MUTE		ALL signal output mute. Mute OFF at 1.5V or less Mute ON at 2.0V or more. Mute OFF when open.	
26	VCC	12.0	VCC	
44 73	GND	0.0	GND	
69	NC		Not connected	



## LA79500E

---

VOUT1/2/3 gain : VOUT1/2/3 output gain selector

- 0 : 0dB output
- 1 : 6dB output

Y/COUT1/2 : Y/VOUT1/2 and COUT1/2, Pr/PbOUT1/2 output gain selector

- 0 : 0dB output
- 1 : 6dB output

L/ROUT1/2/3 gain : LOUT1/2/3 and ROUT1/2/3 output gain selector

- 0 : 0dB output
- 1 : 6dB output

VOUT1/2/3 : These bits select the input signals output to each video output

- |                           |   |
|---------------------------|---|
| 0 : Selects the TV1 input | 4 : Selects the CV3 input                           |
| 1 : Selects the TV2 input | 5 : Selects the CV4 input                           |
| 2 : Selects the CV1 input | 6 : MUTE  |
| 3 : Selects the CV2 input | 7 : MUTE (VOUT1), Y+C (VOUT2 / 3)<br>(VOUT2:Set *2) |

L/ROUT1/2/3(1) : These bits select the input signals output to each Audio L/R output

- |                              |                                       |
|------------------------------|---------------------------------------|
| 0 : Selects the TV1L/R input | 4 : Selects the V3L/R input           |
| 1 : Selects the TV2L/R input | 5 : Selects the V4L/R input           |
| 2 : Selects the V1L/R input  | 6 : MUTE                              |
| 3 : Selects the V2L/R input  | 7 : Selects the Pr/Pb (Cr/Cb) mode *1 |

\*1 L/ROUT1/2/3(2) : This bit selects the input signals output to CP5L/R, CP6L/R output

- 0 : Selects the CP5L/R input
- 1 : Selects the CP6L/R input

VOUT3 Y+C : These bits select the Y+C input signals output to VOUT3 (Y+C mode)

- |                             |                             |
|-----------------------------|-----------------------------|
| 0 : Selects the Y1/C1 input | 2 : Selects the Y3/C3 input |
| 1 : Selects the Y2/C2 input | 3 : Selects the Y4/C4 input |

\*2 Y/C/Pr/PbOUT1/2 & VOUT2 Y+C : These bits select the input signals output to each Video output

- |                             |   |
|-----------------------------|---|
| 0 : Selects the Y1/C1 input | 4 : Selects the Y/CCOMB input, VOUT2 output |
| 1 : Selects the Y2/C2 input | 5 : Selects the Y5/Pr5/Pb5 input            |
| 2 : Selects the Y3/C3 input | 6 : Selects the Y6/Pr6/Pb6 input            |
| 3 : Selects the Y4/C4 input | 7 : Mute                                    |

GPO1/2/3/4/5/6 : This bit set the output from GPIO1/2/3/4/5/6

- 0 : LOW(1.0V or less)
- 1 : HIGH(4.0V or more)

DC\_OUT : These bits set the DC voltage output from Pin67 (DC\_OUT)

- |        |          |
|--------|----------|
| 0 : 0V | 2 : 1.9V |
| 1 : 0V | 3 : 4.5V |

# LA79500E

## Data format (Read mode)

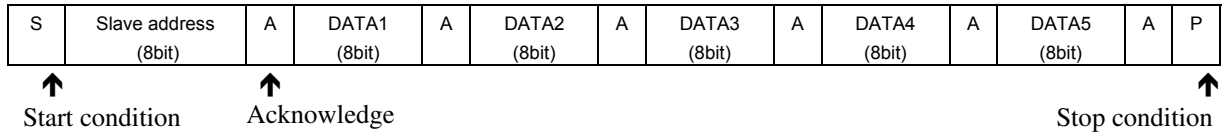

## Read mode

\*: indicates undefined

Data byte								
	MSB D8	D7	D6	D5	D4	D3	D2	LSB D1
DATA1	TV1 0 : No sig. 1 : Signal	TV2 0 : No sig. 1 : Signal	CV1 0 : No sig. 1 : Signal	CV2 0 : No sig. 1 : Signal	CV3 0 : No sig. 1 : Signal	CV4 0 : No sig. 1 : Signal	*	*
DATA2	YCOMB 0 : No sig. 1 : Signal	Y1 0 : No sig. 1 : Signal	Y2 0 : No sig. 1 : Signal	Y3 0 : No sig. 1 : Signal	Y4 0 : No sig. 1 : Signal	Y5 0 : No sig. 1 : Signal	Y6 0 : No sig. 1 : Signal	*
DATA3	GPI1 0 : Low 1 : High	GPI2 0 : Low 1 : High	GPI3 0 : Low 1 : High	GPI4 0 : Low 1 : High	GPI5 0 : Low 1 : High	GPI6 0 : Low 1 : High	DC_IN 00 : 1.3V or less 01 : 1.3V or more to 2.5V or less 10 : 2.5V or more	
DATA4	S-1 SEL 1 : Low 0 : High	S-2 SEL 1 : Low 0 : High	S-3 SEL 1 : Low 0 : High	S-4 SEL 1 : Low 0 : High	*	*	*	*
DATA5	S2-1 00 : 4:3 video sig. 01 : 4:3 Letter-box 10 : 16:9 11 : No sig.		S2-2 00 : 4:3 video sig. 01 : 4:3 Letter-box 10 : 16:9 11 : No sig.		S2-3 00 : 4:3 video sig. 01 : 4:3 Letter-box 10 : 16:9 11 : No sig.		S2-4 00 : 4:3 video sig. 01 : 4:3 Letter-box 10 : 16:9 11 : No sig.	

### S-1 SEL to S-4 SEL

- 1 : S-1 to S-4 pins are grounded.
- 0 : S-1 to S-4 pins are not grounded.

### S2-1 to S2-4

S2-1 to S2-4 are actually determined by comparing the S2-1 to S2-4 pin DC voltages with two threshold. However, when the S-1 to S-4 pins are OPEN(HIGH) the outputs are fixed to "11".

- S2-1 to S2-4 : DATA bit
- 1.3V or less : 00
- 1.3V or more to 2.5V or less : 01
- 2.5V or more : 10
- S-1 to S-4 OPEN (HIGH) : 11

1) Data transfer manual : [1] is High level. [0] is Low level.

I<sup>2</sup>C-BUS control system is adopted in SW LSI and SW LSI is controlled by SCL (Serial Clock) and SDA (Serial Data). At first, please set up the START condition\*1 by these two terminals (SCL and SDA). And next, please input the 8bits data which should be synchronized with SCL into SDA terminal Still more, please give priority to high rank bit at data transfer order (MSB→LSB). The 9th bit is called as ACK (Acknowledge), SW LSI sends [0] to the SDA terminal during SCL [1] period. So, please open the port of micro-processor during this period. And next, please transfer sub-address data (called as Group) and control data. As thus the Data transfer Stop condition\*2 is finished.

\*1 : SDA rise up during SCL is [1]      \*2 : SDA fall down during SCL is [1]

2) Transfer data format

The transfer data is composed by START condition , Slave address data, sub-address data, control data and STOP condition.

There are 6 control groups.

After setting up the START condition, please transfer the Slave Address. sub-address data and next control data (Please see the Fig.1)

Slave Address is composed by 7bits, and this bit 8th bit should be set as [0] at write mode and [1] at read mode.

This 8th bit called as R/W bit, and this bit shows the data transmission direction. [0] means send mode (accept mode with SW LSI) and [1] means accept mode (send mode with SW LSI) fundamentally.

The both of sub-address data and control data are composed by 8bits, and the one control action is defined with combination of these two data. And if you want to control 2 or more groups at the same mode, you can realize it by sending some control data together.

The data makes meaning with all bits, so you cannot stop the sending until all data transfer is over. If you want to stop transfer action, please transfer the STOP condition.

You can select how to send as follws.(write mode)

Pattern A Start condition + Slave Address + Sub Address 00 + Data 00 + Data 01 + Data 02 + Data 03 + Data 04 + Data 05 + Stop condition

Pattern B Start condition + Slave Address + Sub Address 01 + Data 01 + Data 02 + Data 03 + Data 04 + Data 05 + Stop condition

Pattern C Start condition + Slave Address + Sub Address 02 + Data 02 + Data 03 + Data 04 + Data 05 + Stop condition

Pattern D Start condition + Slave Address + Sub Address 03 + Data 03 + Data 04 + Data 05 + Stop condition

Pattern E Start condition + Slave Address + Sub Address 04 + Data 04 + Data 05 + Stop condition

Pattern F Start condition + Slave Address + Sub Address (01 or 02 or 03 or 04 or 05) + Data (01 or 02 or 03 or 04 or 05) + Stop condition (send only 1Data)

START condition	Slave Address	R/W	ACK	Sub-Address	ACK	Control data	ACK	...	STOP condition
-----------------	---------------	-----	-----	-------------	-----	--------------	-----	-----	----------------

Fig.1 Data Structure

## 3) Initialize

SW LSI is initialized as the following mode for circuit protection. Please see “SERIAL CONTROL TABLE”.

### Characteristics of the SDA and SCL I/O stages for SW LSI

Parameter	Symbol	Ratings		Unit
		Min	Max	
LOW level input voltage	VIL	0	1.5	V
HIGH level input voltage	VIH	3.5	5.0	V
LOW level output current	IOL		3.0	mA
SCL clock frequency	fSCL		100	kHz
Set-up time for a repeated START condition	tSU:STA	4.7		μs
Hold time START condition. After this period, the first clock pulse is generated.	tHD:STA	4.0		μs
LOW period of the SCL clock	tLOW	4.7		μs
Rise time of both SDA and SDL signals	tR	0	1.0	μs
HIGH period of the SCL clock	tHIGH	4.0		μs
Fall time of both SDA and SDL signals	tF	0	1.0	μs
Data hold time	tHD:DAT	0		μs
Data set-up time	tSU:DAT	250		ns
Set-up time for STOP condition	tSU:STO	4.0		μs
BUS fred time between a STOP and START condition	tBUF	4.7		μs

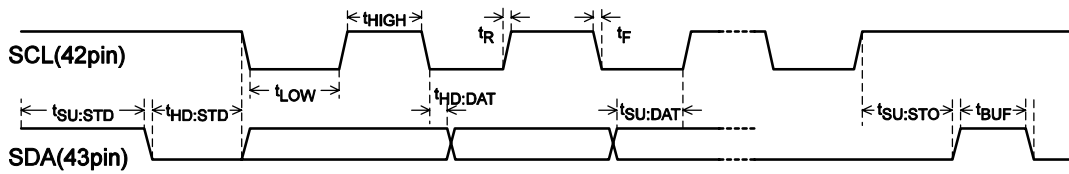
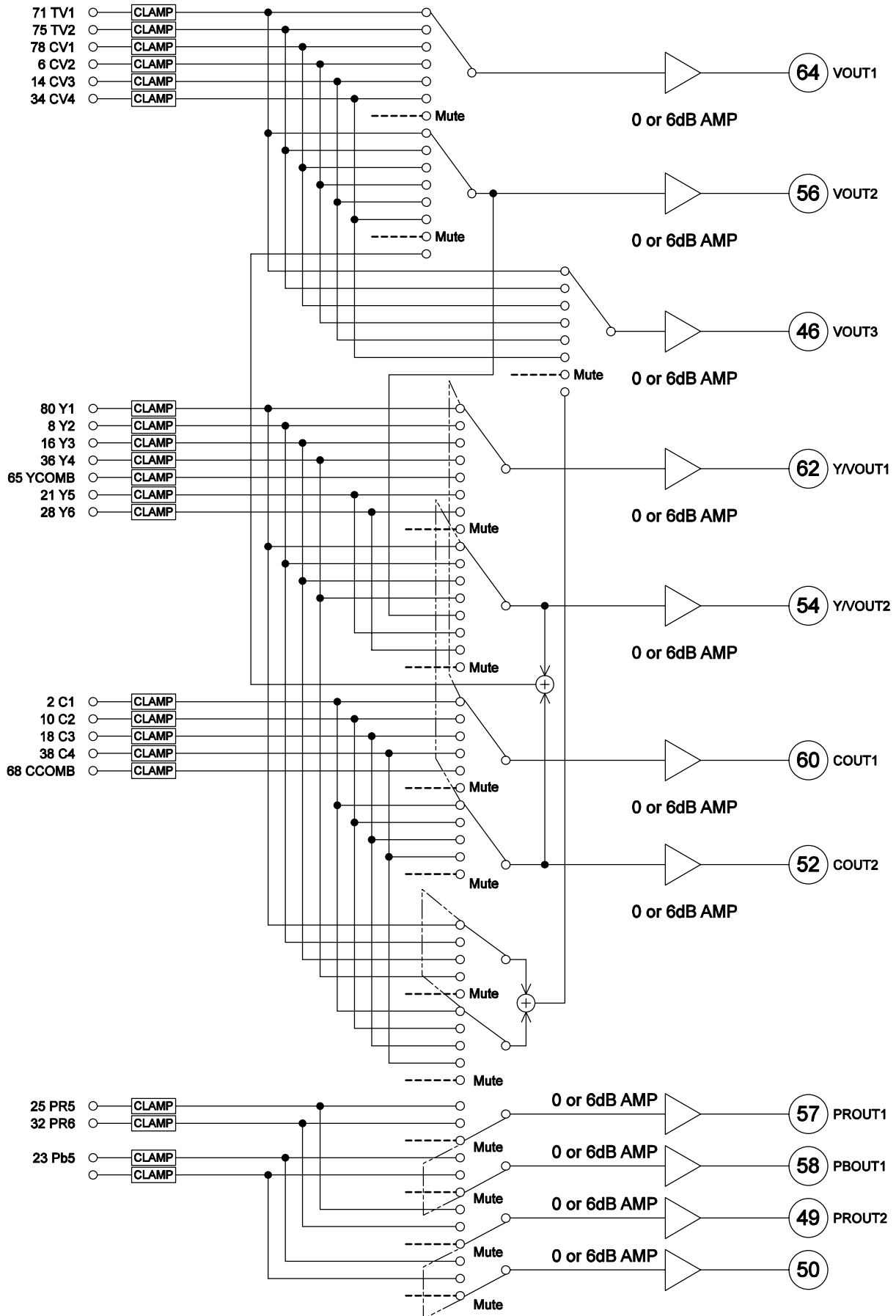

Fig.2 Definition of timing

# LA79500E

## Video Block



Audio Block

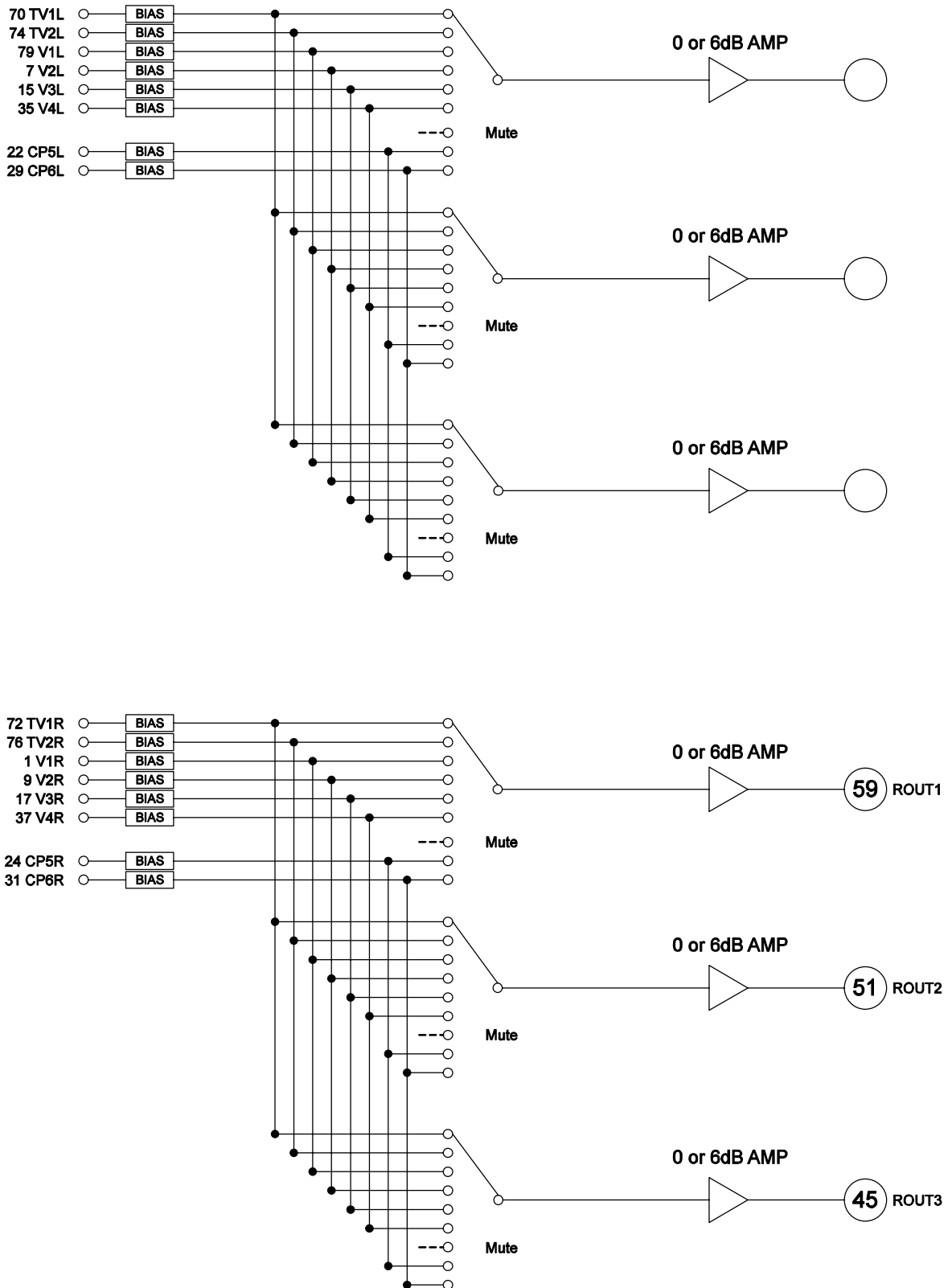

Test Circuit

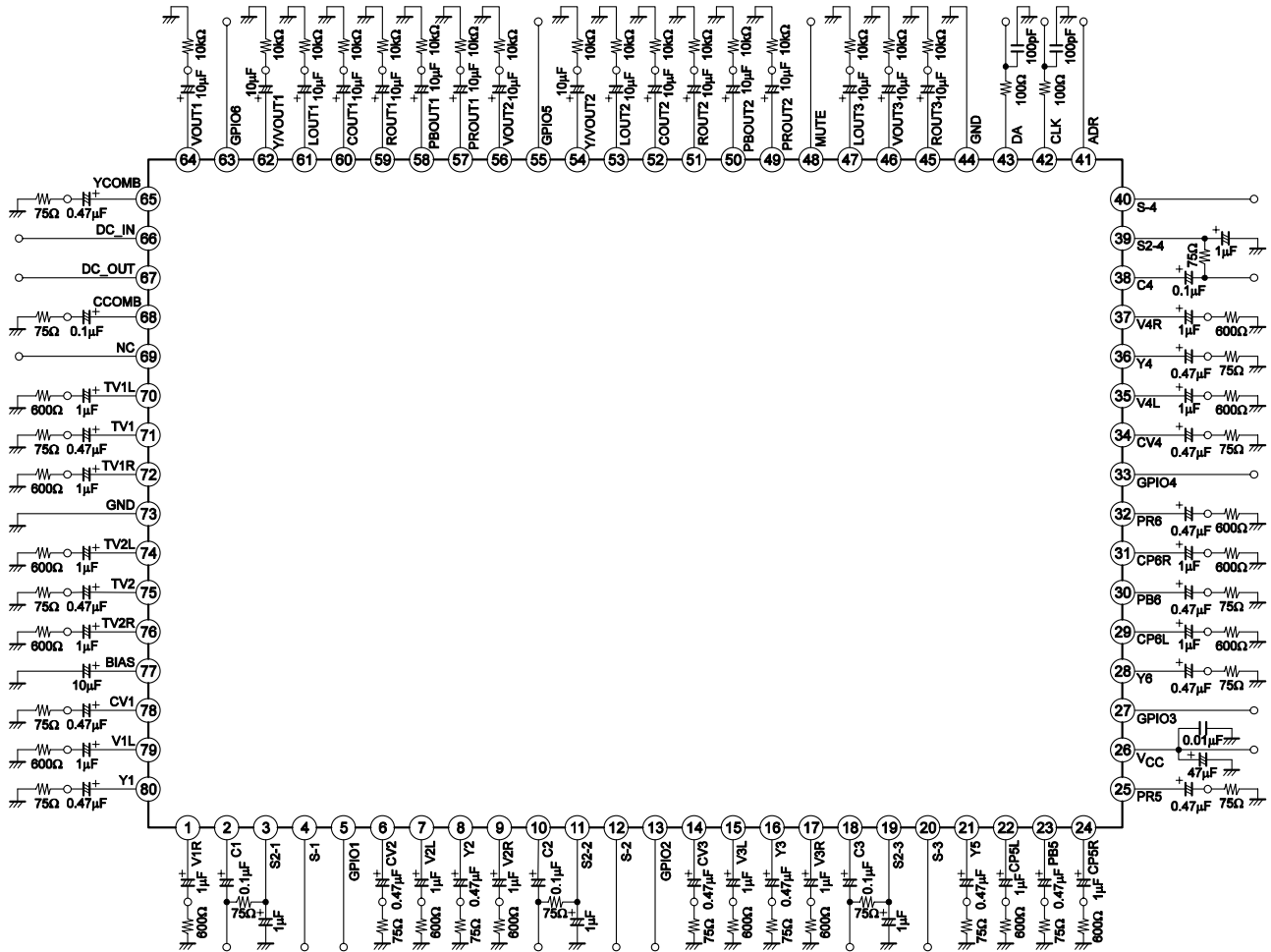

- Specifications of any and all SANYO Semiconductor products described or contained herein stipulate the performance, characteristics, and functions of the described products in the independent state, and are not guarantees of the performance, characteristics, and functions of the described products as mounted in the customer's products or equipment. To verify symptoms and states that cannot be evaluated in an independent device, the customer should always evaluate and test devices mounted in the customer's products or equipment.
- SANYO Semiconductor Co., Ltd. strives to supply high-quality high-reliability products. However, any and all semiconductor products fail with some probability. It is possible that these probabilistic failures could give rise to accidents or events that could endanger human lives, that could give rise to smoke or fire, or that could cause damage to other property. When designing equipment, adopt safety measures so that these kinds of accidents or events cannot occur. Such measures include but are not limited to protective circuits and error prevention circuits for safe design, redundant design, and structural design.
- In the event that any or all SANYO Semiconductor products (including technical data, services) described or contained herein are controlled under any of applicable local export control laws and regulations, such products must not be exported without obtaining the export license from the authorities concerned in accordance with the above law.
- No part of this publication may be reproduced or transmitted in any form or by any means, electronic or mechanical, including photocopying and recording, or any information storage or retrieval system, of otherwise, without the prior written permission of SANYO Semiconductor Co., Ltd.
- Any and all information described or contained herein are subject to change without notice due to product/technology improvement, etc. When designing equipment, refer to the "Delivery Specification" for the SANYO Semiconductor product that you intend to use.
- Information (including circuit diagrams and circuit parameters) herein is for example only; it is not guaranteed for volume production. SANYO Semiconductor believes information herein is accurate and reliable, but no guarantees are made or implied regarding its use or any infringements of intellectual property rights or other rights of third parties.

This catalog provides information as of November, 2006. Specifications and information herein are subject to change without notice.