



ON Semiconductor®

<http://onsemi.com>

LV8491CT

Bi-CMOS LSI

Piezo Actuator Driver IC

Overview

The LV8491CT is a piezoelectric actuator driver IC. It internally generates drive waveforms and this makes it possible to control piezoelectric actuators with simple instructions.

Features

- Actuators using piezoelectric elements can be driven and controlled simply by I²C communication.
- Multiple patterns of drive waveform conditions can be set for before and after performing normal operation when executing the DRVPULSE instruction.
- The piezoelectric drive waveforms are set externally by serial input signals using the I²C interface.
The rising and falling timings are determined with clock count.
- Startup/stop of the IC is controlled by ENIN register input through I²C communication.
- The time for which the actuator is driven is determined with the drive frequency setting based on I²C communication.
- BUSY output can be used to identify the operation/stop state of the actuator while output is present at the OUT pin.
The BUSY signal can also be checked with the READ function controlled through I²C communication.
- Built-in undervoltage detection and protection circuit, and register power-on reset function.

Specifications

Absolute Maximum Ratings at Ta = 25°C, GND = 0V

Parameter	Symbol	Conditions	Ratings	Unit
Supply voltage	V _{CC} max		-0.5 to 5.0	V
Output current	I _O max		300	mA
Peak output current 1	I _O peak 1	t ≤ 1ms	750	mA
Peak output current 2	I _O peak 2	t ≤ 10μs	1200	mA
Input signal voltage	V _{IN} max		-0.5 to V _{CC} +0.5	V
Allowable dissipation	Pd	*Mounted on a specified board.	350	mW
Operating temperature	T _{opr}		-30 to +85	°C
Storage temperature	T _{stg}		-55 to +125	°C

* Specified board : 40mm × 40mm × 1.6mm, glass epoxy board.

Stresses exceeding Maximum Ratings may damage the device. Maximum Ratings are stress ratings only. Functional operation above the Recommended Operating Conditions is not implied. Extended exposure to stresses above the Recommended Operating Conditions may affect device reliability.

LV8491CT

Allowable Operating Conditions at Ta = 25°C, GND = 0V

Parameter	Symbol	Conditions	Ratings	Unit
Supply voltage	V _{CC}		2.2 to 3.3	V
Input signal voltage	V _{IN}		-0.3 to V _{CC}	V
Corresponding CLK input frequency	F _{clk}		to 60	MHz
Maximum operating frequency	Ct max		Set STP count × 512	Times

Electrical Characteristics at Ta = 25°C, V_{CC} = 2.8V, GND = 0V, unless otherwise specified.

Parameter	Symbol	Conditions	Ratings			Unit
			min	typ	max	
Standby mode current drain	I _{CC0}	No CLK input, When SCL/SDA = L			1.0	μA
Operating mode current drain	I _{CC1}	CLK = 10MHz, When SCL/SDA = H		0.5	1.0	mA
High-level input voltage	V _{IH}	2.2V ≤ V _{CC} ≤ 3.3V SCL, SDA	1.4		V _{CC} +0.3	V
Low-level input voltage	V _{IL}	2.2V ≤ V _{CC} ≤ 3.3V SCL, SDA	-0.3		0.4	V
CLK pin high-level input voltage	V _{IH2}	CLK	0.5×V _{CC}		V _{CC} +0.3	V
CLK pin low-level input voltage	V _{IL2}	CLK	-0.3		0.2×V _{CC}	V
BUSY pin high-level output voltage	B _{OH}	With no load	V _{CC} -0.15		V _{CC}	V
BUSY pin low-level output voltage	B _{OL}	With no load	0		0.15	V
BUSY pin leakage current	BLK				1.0	μA
BUSY pin sink current	Blsk	BUSY pin voltage when BUSY is set low = 2.8V	1.5	2.2		mA
BUSY pin source current	Blso	BUSY pin voltage when BUSY is set high = 0V	1.5	2.2		mA
Low voltage detection voltage	V _{res}	V _{CC} voltage	1.8	2.0	2.2	V
Output block upper-side on resistance	RonP			0.8	1.5	Ω
Output block lower-side on resistance	RonN			0.6	1.2	Ω
Turn on time	TPLH	With no load *1			0.15	μS
Turn off time	TPHL	With no load *1			0.1	μS

*1 : Rising time from 10 to 90% and falling time from 90 to 10% are specified with regard to the OUT pin voltage.

Package Dimensions

unit : mm (typ)

3399

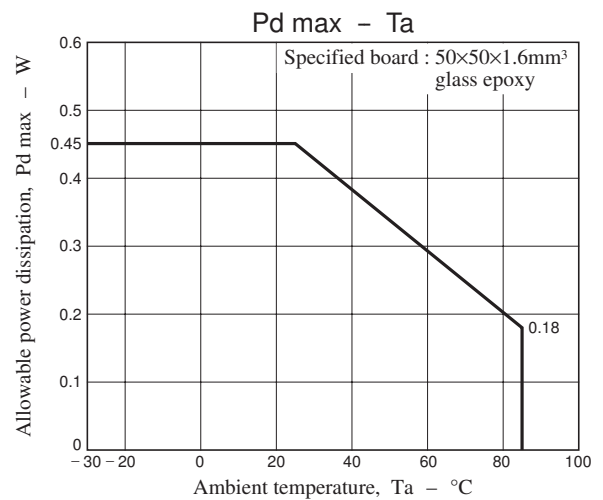
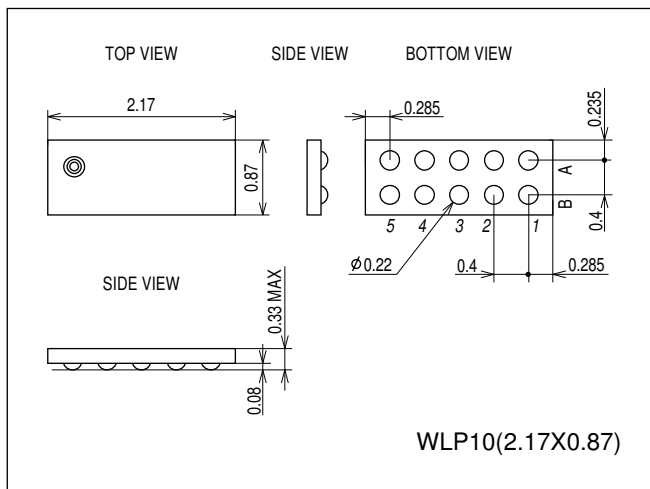

Pin Assignment

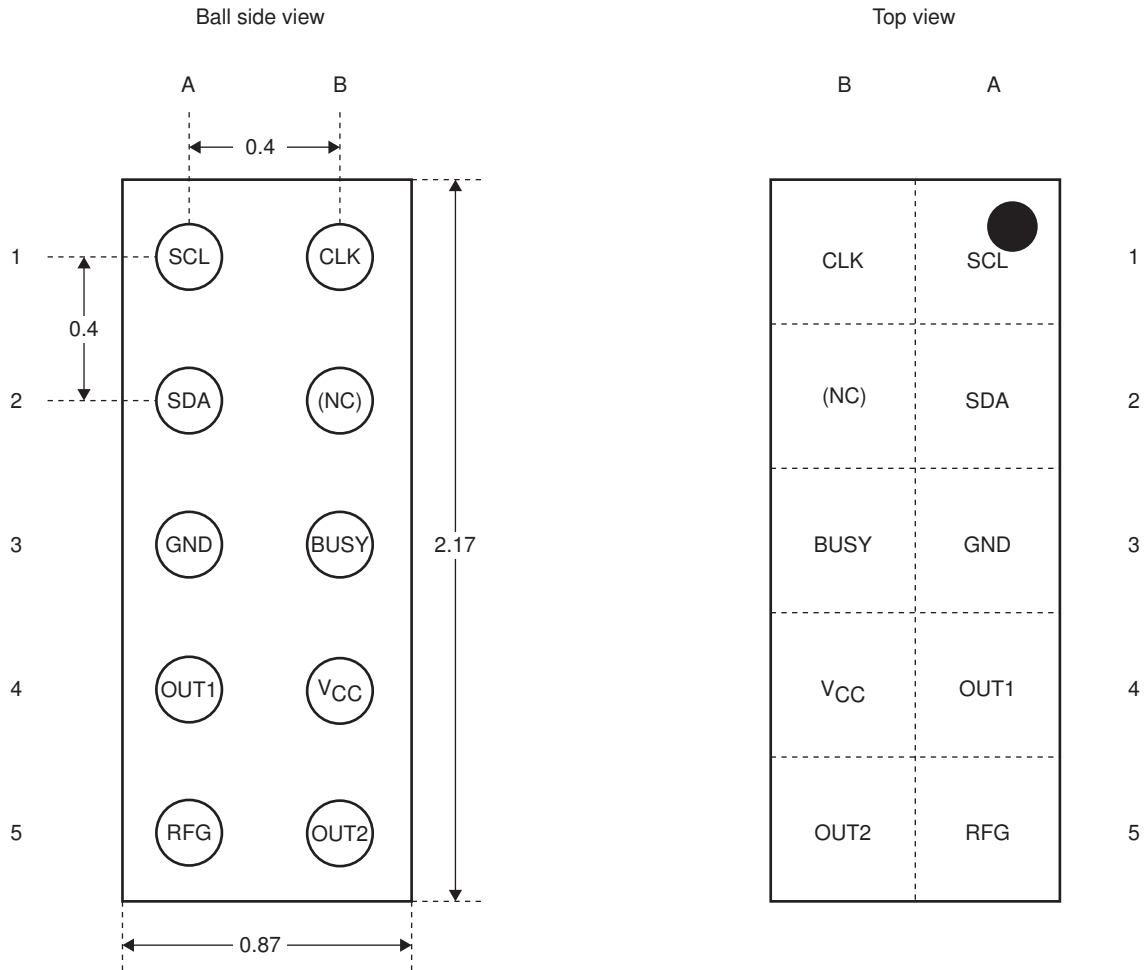

- A1:SCL
- A2:SDA
- A3:GND
- A4:OUT1
- A5:RFG
- B1:CLK
- B2:(NC)
- B3:BUSY
- B4:V_{CC}
- B5:OUT2

LV8491CT

Block Diagram

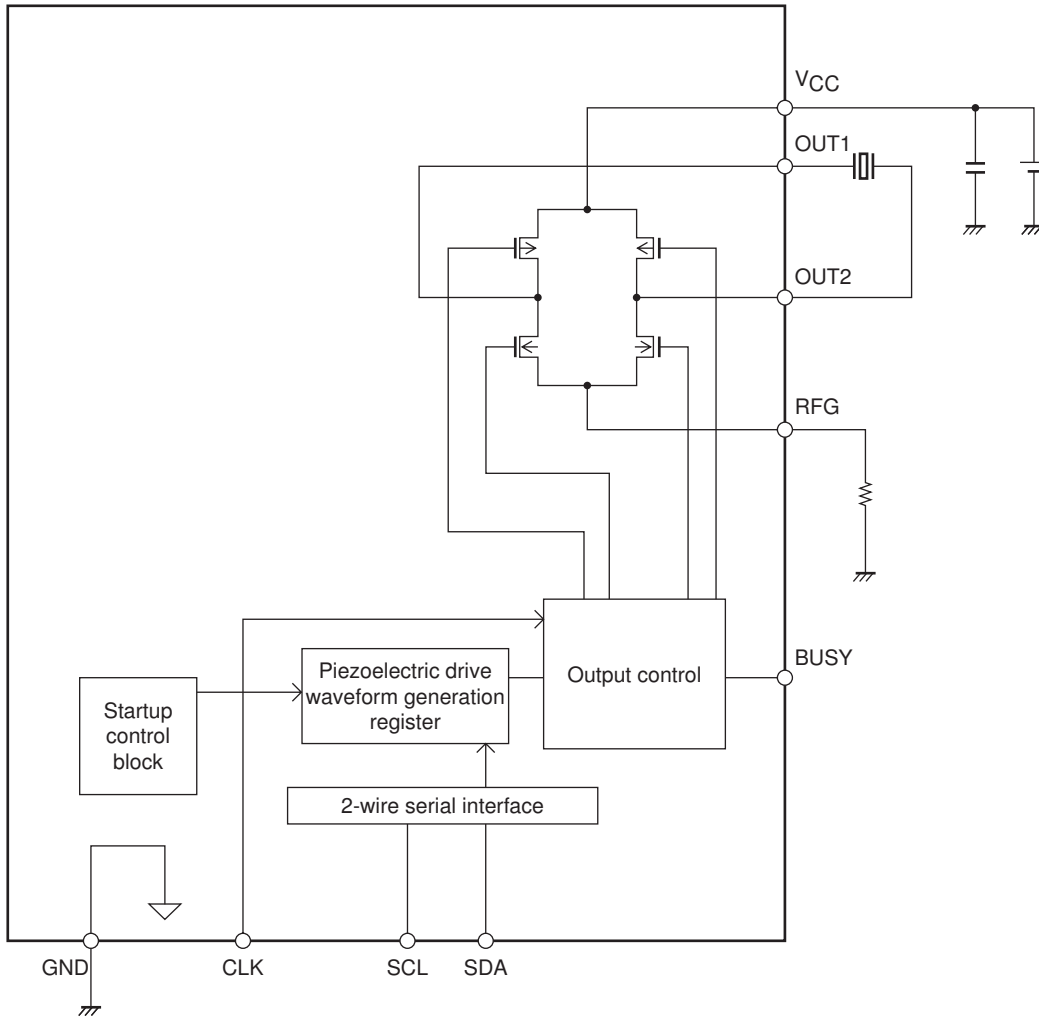

Value of the resistor connected to the RFG pin

Inrush current flowing to the piezoelectric elements can be controlled in the LV8491CT by inserting a resistor between the RFG pin and GND potential.

Since the resistance affects the actuator operation, the constant must be determined in a range from 0 to 3.3Ω while monitoring the operation of the actuator.

Capacitor on the VCC line

Piezoelectric actuators are capacitive loads in electrical terms, and they operate units by charging and discharging the charges. Since the charge between the capacitor on the VCC line and piezoelectric elements is transferred, the capacitor must be mounted near the VCC pin. The capacitance of the capacitor required is determined by the capacitance of the piezoelectric element. A capacitance within a range that does not affect operation must be selected.

LV8491CT

Serial Bus Communication Specifications

I²C serial transfer timing conditions

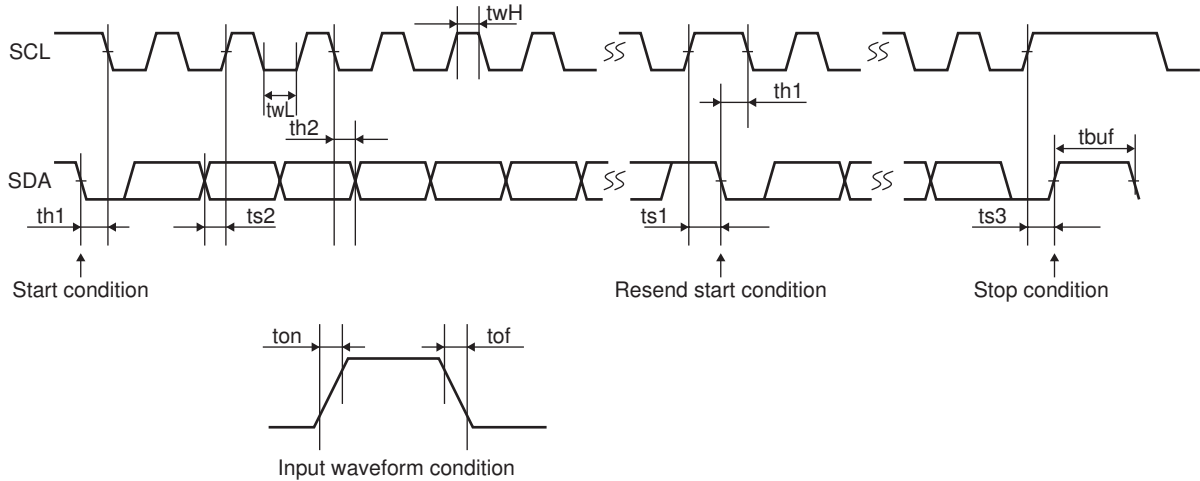

Standard mode

Parameter	symbol	Conditions	min	typ	max	unit
SCL clock frequency	f _{scl}	SCL clock frequency	0		100	kHz
Data setup time	ts ₁	Setup time of SCL with respect to the falling edge of SDA	4.7			μs
	ts ₂	Setup time of SDA with respect to the rising edge of SCL	250			ns
	ts ₃	Setup time of SCL with respect to the rising edge of SDA	4.0			μs
Data hold time	th ₁	Hold time of SCL with respect to the rising edge of SDA	4.0			μs
	th ₂	Hold time of SDA with respect to the falling edge of SCL	0.06			μs
Pulse width	tw _L	SCL low period pulse width	4.7			μs
	tw _H	SCL high period pulse width	4.0			μs
Input waveform conditions	ton	SCL/SDA (input) rising time			1000	ns
	tof	SCL/SDA (input) falling time			300	ns
Bus free time	t _{buf}	Interval between stop condition and start condition	4.7			μs

High-speed mode

Parameter	Symbol	Conditions	min	typ	max	unit
SCL clock frequency	f _{scl}	Clock frequency of SCL	0		400	kHz
Data setup time	ts ₁	Setup time of SCL with respect to the falling edge of SDA	0.6			μs
	ts ₂	Setup time of SDA with respect to the rising edge of SCL	100			ns
	ts ₃	Setup time of SCL with respect to the rising edge of SDA	0.6			μs
Data hold time	th ₁	Hold time of SCL with respect to the rising edge of SDA	0.6			μs
	th ₂	Hold time of SDA with respect to the falling edge of SCL	0.06			μs
Pulse width	tw _L	SCL low period pulse width	1.3			μs
	tw _H	SCL high period pulse width	0.6			μs
Input waveform conditions	ton	SCL/SDA (input) rise time			300	ns
	tof	SCL/SDA (input) fall time			300	ns
Bus free time	t _{buf}	Interval between the stop condition and the start condition	1.3			μs

LV8491CT

I²C bus transfer method

Start and stop conditions

The I²C bus requires that the state of SDA be preserved while SCL is high as shown in the timing diagram below during a data transfer operation.

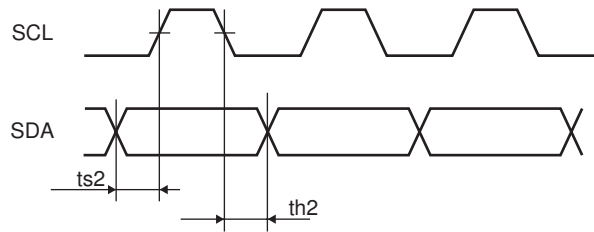

When data is not being transferred, both SCL and SDA are in the high state. The start condition is generated and access is started when SDA is changed from high to low while SCL and SDA are high.

Conversely, the stop condition is generated and access is ended when SDA is changed from low to high while SCL is high.

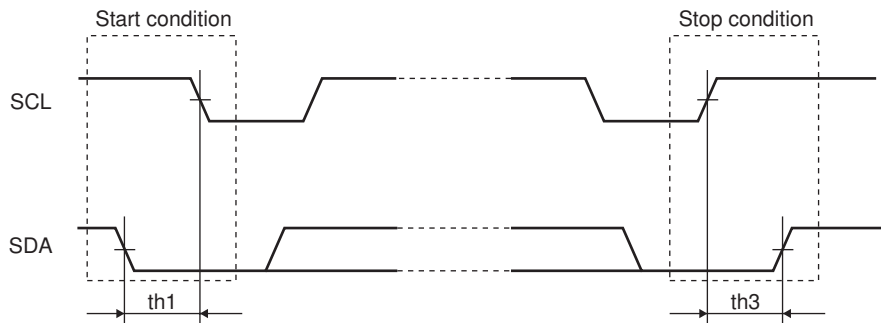

LV8491CT

Data transfer and acknowledgement response

After the start condition is generated, data is transferred one byte (8 bits) at a time. Any number of data bytes can be transferred consecutively.

An ACK signal is sent to the sending side from the receiving side every time 8 bits of data are transferred. The transmission of an ACK signal is performed by setting the receiving side SDA to low after SDA at the sending side is released immediately after the clock pulse of SCL bit 8 in the data transferred has fallen low.

After the receiving side has sent the ACK signal, if the next byte transfer operation is to receive only the byte, the receiving side releases SDA on the falling edge of the 9th clock of SCL.

There are no CE signals in the I²C bus ; instead, a 7-bit slave address is assigned to each device, and the first byte of the transfer data is allocated to the 7-bit slave address and to the command (R/W) which specifies the direction of subsequent data transfer.

The READ function of the LV8491CT provides only the functionality to test the BUSY state.

7-bit address data is transferred sequentially starting at the MSB and the second and subsequent bytes are written if the state of the 8th bit is low and read if the state is high.

In the LV8491CT, the slave address is stipulated to be “1110010.”.

WRITE mode timing

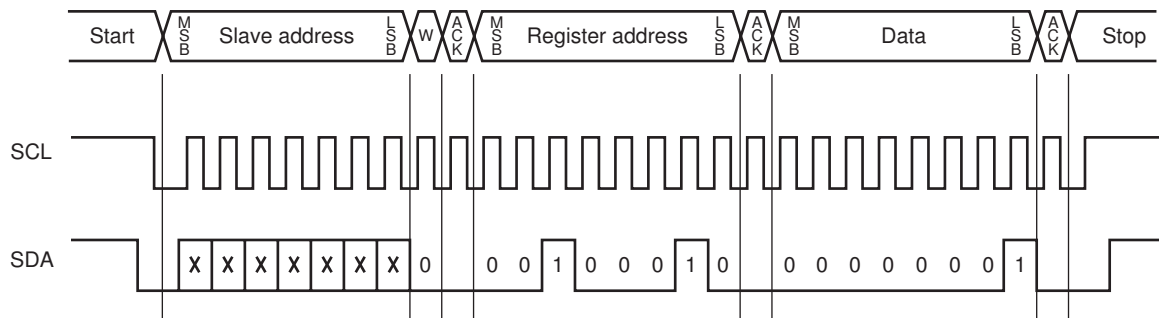

READ mode timing

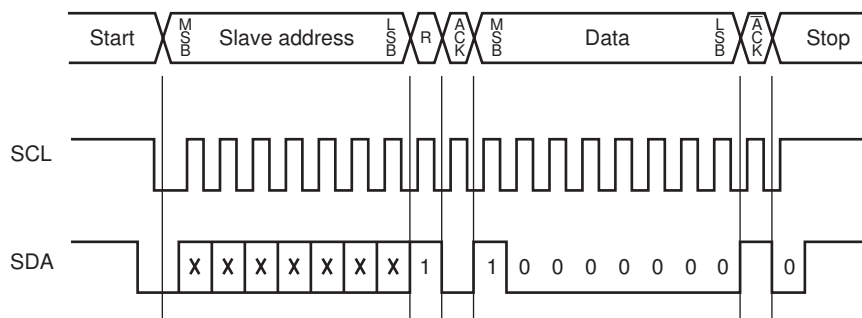

LV8491CT

Data transfer write format

The slave address and Write command must be allocated to the first byte and the register address in the serial map must be designated in the second byte.

For the third byte, data transfer is carried out to the address designated by the register address which is written in the second byte. Subsequently, if data continues, the register address value is automatically incremented for the fourth and subsequent bytes.

Thus, continuous data transfer starting at the designated address is made possible.

After the register address reaches 1Fh, the transfer address for the next byte is set to 00h.

Data write example

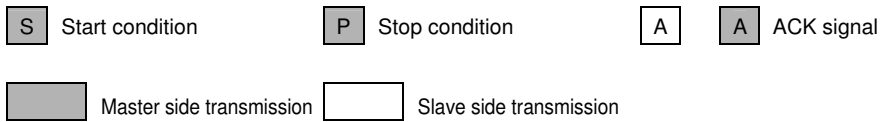
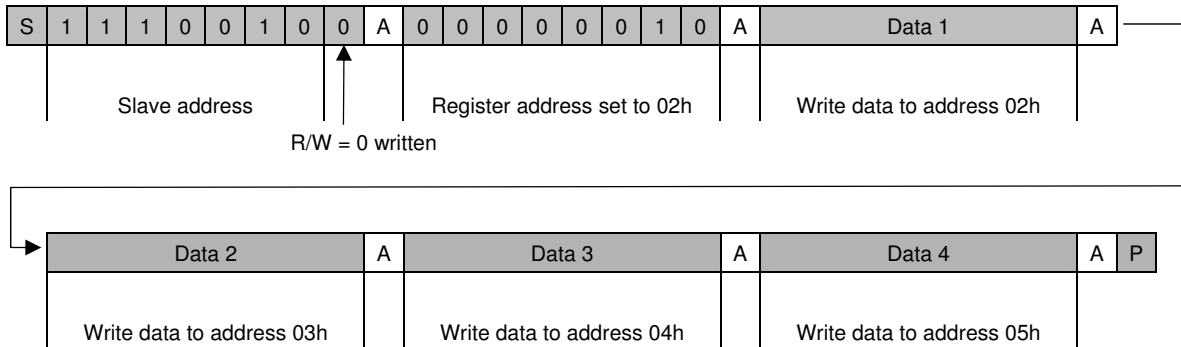

Data read example

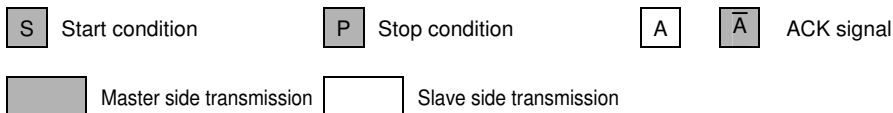
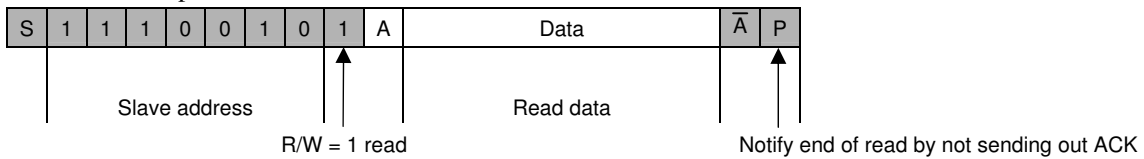

LV8491CT

Serial Map

		Register Address								Data							
		A7	A6	A5	A4	A3	A2	A1	A0	D7	D6	D5	D4	D3	D2	D1	D0
0		0	0	0	0	0	0	0	0	M/I	DRV PULSE [6 : 0]						
		0	0	0	0	0	0	0	0	0	0	0	0	0	0	0	0
1		0	0	0	0	0	0	0	1	GATE	x	ENIN	CKSEL [1 : 0]		RET [1 : 0]		INIT
		0	0	0	0	0	0	0	1	0	0	0	0	0	0	0	0
2		0	0	0	0	0	0	1	0	RST [7 : 0]							
		0	0	0	0	0	0	1	0	0	0	0	0	0	0	0	0
3		0	0	0	0	0	0	1	1	GTAS [7 : 0]							
		0	0	0	0	0	0	1	1	0	0	0	0	0	0	0	0
4		0	0	0	0	0	1	0	0	GTBR [7 : 0]							
		0	0	0	0	0	1	0	0	0	0	0	0	0	0	0	0
5		0	0	0	0	0	1	0	1	GTBS [7 : 0]							
		0	0	0	0	0	1	0	1	0	0	0	0	0	0	0	0
6		0	0	0	0	0	1	1	0	STP [7 : 0]							
		0	0	0	0	0	1	1	0	0	0	0	0	0	0	0	0
7		0	0	0	0	0	1	1	1	x	x	x	x	INITMOV [7 : 4]			
		0	0	0	0	0	1	1	1	0	0	0	0	0	0	0	0
8		0	0	0	0	1	0	0	0	x	x	NRPULSE1 [5 : 0]					
		0	0	0	0	1	0	0	0	0	0	0	0	0	0	0	0
9		0	0	0	0	1	0	0	1	x	x	NRP-A [5 : 0]					
		0	0	0	0	1	0	0	1	0	0	0	0	0	0	0	0
10		0	0	0	0	1	0	1	0	x	x	NRP-B [5 : 0]					
		0	0	0	0	1	0	1	0	0	0	0	0	0	0	0	0
11		0	0	0	0	1	0	1	1	x	x	NRP-C [5 : 0]					
		0	0	0	0	1	0	1	1	0	0	0	0	0	0	0	0
12		0	0	0	0	1	1	0	0	x	x	NRP-D [5 : 0]					
		0	0	0	0	1	1	0	0	0	0	0	0	0	0	0	0
13		0	0	0	0	1	1	0	1	x	x	NRPULSE2 [5 : 0]					
		0	0	0	0	1	1	0	1								
14		0	0	0	0	1	1	1	0	x	x	NRP-E [5 : 0]					
		0	0	0	0	1	1	1	0	0	0	0	0	0	0	0	0
15		0	0	0	0	1	1	1	1	x	x	NRP-F [5 : 0]					
		0	0	0	0	1	1	1	1	0	0	0	0	0	0	0	0
16		0	0	0	1	0	0	0	0	x	x	NRP-G [5 : 0]					
		0	0	0	1	0	0	0	0	0	0	0	0	0	0	0	0
17		0	0	0	1	0	0	0	1	x	x	NRP-H [5 : 0]					
		0	0	0	1	0	0	0	1	0	0	0	0	0	0	0	0
18		0	0	0	1	0	0	1	0	NR1GTBR [7 : 0]							
		0	0	0	1	0	0	1	0	0	0	0	0	0	0	0	0
19		0	0	0	1	0	0	1	1	NR1GTBS [7 : 0]							
		0	0	0	1	0	0	1	1	0	0	0	0	0	0	0	0
20		0	0	0	1	0	1	0	0	NR2GTBR [7 : 0]							
		0	0	0	1	0	1	0	0	0	0	0	0	0	0	0	0
21		0	0	0	1	0	1	0	1	NR2GTBS [7 : 0]							
		0	0	0	1	0	1	0	1	0	0	0	0	0	0	0	0
22		0	0	0	1	0	1	1	0	NR3GTBR [7 : 0]							
		0	0	0	1	0	1	1	0	0	0	0	0	0	0	0	0
23		0	0	0	1	0	1	1	1	NR3GTBS [7 : 0]							
		0	0	0	1	0	1	1	1	0	0	0	0	0	0	0	0

Upper : Register name Lower : Default value

Continued on next page.

LV8491CT

Continued from preceding page.

		Register Address							Data								
		A7	A6	A5	A4	A3	A2	A1	A0	D7	D6	D5	D4	D3	D2	D1	D0
24	0	0	0	0	1	1	0	0	0	NR4GTBR [7 : 0]							
		0	0	0	0	0	0	0	0	0	0	0	0	0	0	0	0
25	0	0	0	0	1	1	0	0	1	NR4GTBS [7 : 0]							
		0	0	0	0	0	0	0	0	0	0	0	0	0	0	0	0
26	0	0	0	0	1	1	0	1	0	NR5GTBR [7 : 0]							
		0	0	0	0	0	0	0	0	0	0	0	0	0	0	0	0
27	0	0	0	0	1	1	0	1	1	NR5GTBS [7 : 0]							
		0	0	0	0	0	0	0	0	0	0	0	0	0	0	0	0
28	READ mode only register									BUSY	x	x	x	x	x	x	x
										0	0	0	0	0	0	0	0

Upper : Register name Lower : Default value

NR drive pulse output

Rise operation

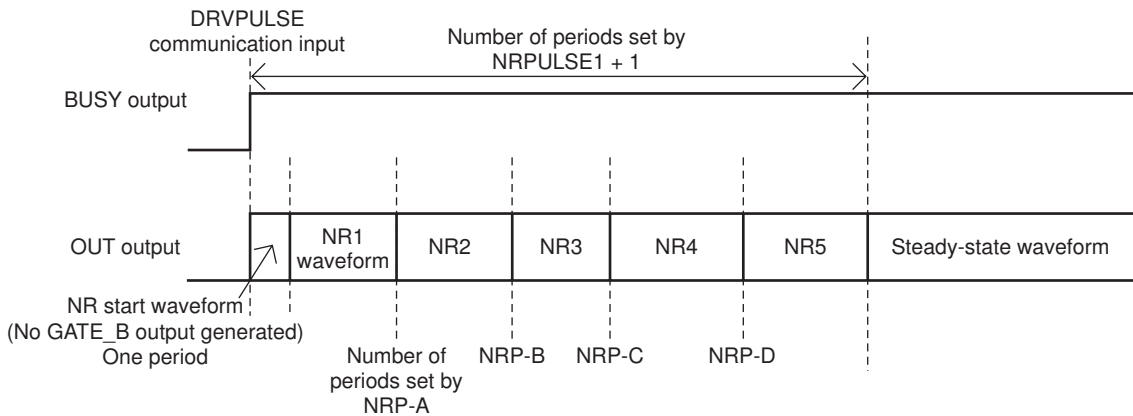

For example, when NRPULSE1 is set to 15, NRP-A to 3, NRP-B to 6, NRP-C to 9, and NRP-D to 12, one period of the NR start waveform (no GATE_B output) is output, followed by three periods of the NR1 waveform, three periods of the NR2 waveform, three periods of the NR3 waveform, three periods of the NR4 waveform, three periods of the NR5 waveform, and then STP x DRVPULSE periods of the steady-state waveform.

When NRPULSE1 is set to 0, no NR pulse is generated and the same output as the normal DRVPULSE input is generated. In addition, when NRP-A and NRP-B are set the same value, the NR2 waveform is not output, and the NR3 waveform is output following the NR1 waveform.

Fall operation

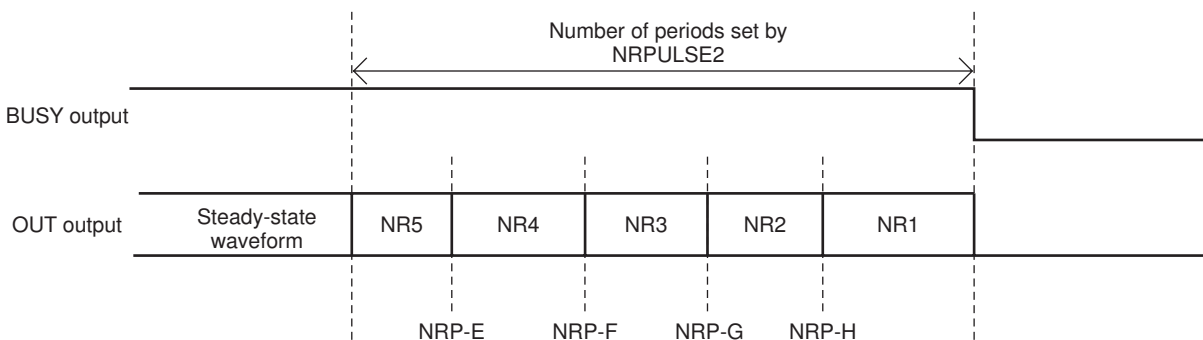

The fall waveforms are output in order from the NR5 waveform to the NR1 waveform. The switching timing is set in the same manner as that for rise operation.

NR drive waveform settings

The settings are the same as those for the normal drive waveform. Drive waveforms are generated using the same parameters as the normal waveform for RST and GTAS, and the NR waveform setting values for GTBR and GTBS.

Example: NR1 waveform

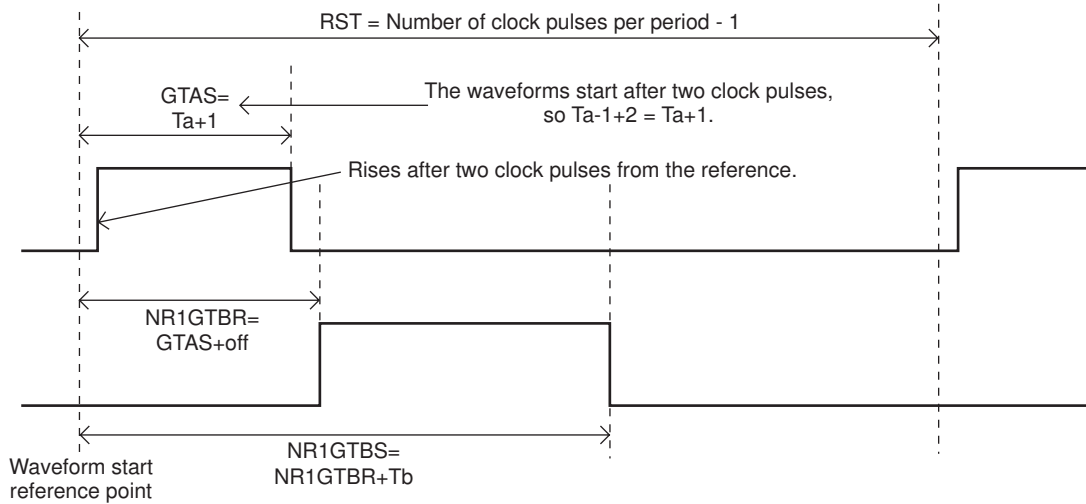

NR start waveform

NR waveform output control is as follows. When NRPULSE1 is set, a waveform without GATE_B output is output in the first rise period. After that the waveforms set by NR are output in order from NR1.

When there are no NR settings for rise operation (when NRPULSE = 0), the NR start waveform is not output.

The same parameters as those of the normal waveform are referenced for RST and GTAS, and GTBR and GTBS are zero input waveforms.

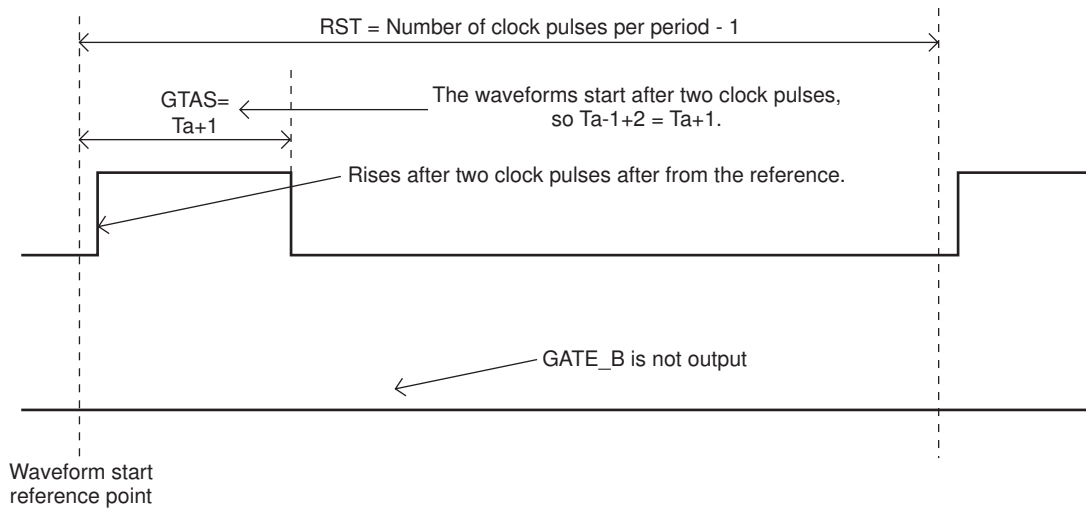

LV8491CT

Serial Mode Settings

0	0	0	0	0	0	0	0	0	0	D7	D6	D5	D4	D3	D2	D1	D0
---	---	---	---	---	---	---	---	---	---	----	----	----	----	----	----	----	----

D0 to D6: DRVPULSE [6 : 0]

Operation count setting register. Specify a number from 0 to 127.

The number of cyclic operations determined by <DRVPULSE setting> × <STP setting> are performed.

Additional data can be input and data is added up to the equivalent of total of 512 pulses.

However, when the EN pin is set low or ENIN is set to 0, the DRVPULSE counter is in the reset state, so DRVPULSE input is not accepted.

Output operation is performed when DRVPULSE input is recognized, and OUT output starts according to the waveform setting registers when the ACK signal is output after a 00h address instruction.

D7	M/I
0	∞
1	macro

Operation direction switching

*Default Infinity distance direction
 Macro direction

Operation direction switching register

The operation count setting register is reset when the register is switched. To stop the operation of the unit, switch the M/I register and set DRVPULSE to 0 for input. This register is also used to set the direction of operation when the initialization sequence is to be performed.

1	0	0	0	0	0	0	0	0	1	D7	0	D5	D4	D3	D2	D1	D0
---	---	---	---	---	---	---	---	---	---	----	---	----	----	----	----	----	----

D0: Register for selecting whether the initialization sequence is to be performed when the ENIN input changes from 0 to 1.

D0	INIT
0	Initialization to be performed
1	Initialization not to be performed

Initialization to be performed/not to be performed setting

*Default

D2	D1	RET
0	0	2 times
0	1	1 time
1	0	3 times
1	1	4 times

Number of initialization sequence swing back

*Default

D4	D3	CKSEL
0	0	1/4
0	1	1/2
1	0	1
1	1	1

Input clock division ratio switching

*Default 1/4
 1/2
 1 (no frequency division)
 1 (no frequency division)

D5 : ENIN ENIN register is used to start up IC and to give a trigger for initial operation initialization.

Output operation of the IC is performed only when ENIN is set to 1.

D7	GATE
0	MODE1
1	MODE2

Gate mode operation

*Default Forward/reverse/braking
 Forward/reverse/standby

LV8491CT

2	0	0	0	0	0	0	1	0	D7	D6	D5	D4	D3	D2	D1	D0
---	---	---	---	---	---	---	---	---	----	----	----	----	----	----	----	----

RST7 to RST0 : Specifies the number of clocks per period (0 to 255). Default = 0

3	0	0	0	0	0	0	1	1	D7	D6	D5	D4	D3	D2	D1	D0
---	---	---	---	---	---	---	---	---	----	----	----	----	----	----	----	----

GTAS7 to GTAS0 : Sets the GATE_A pulse set value (0 to 255). Default = 0

4	0	0	0	0	0	1	0	0	D7	D6	D5	D4	D3	D2	D1	D0
---	---	---	---	---	---	---	---	---	----	----	----	----	----	----	----	----

GTBR7 to GTBR0 : Sets the GATE_B pulse reset value (0 to 255). Default = 0

5	0	0	0	0	0	1	0	1	D7	D6	D5	D4	D3	D2	D1	D0
---	---	---	---	---	---	---	---	---	----	----	----	----	----	----	----	----

GTBS7 to GTBS0 : Sets the GATE_B pulse set value (0 to 255). Default = 0

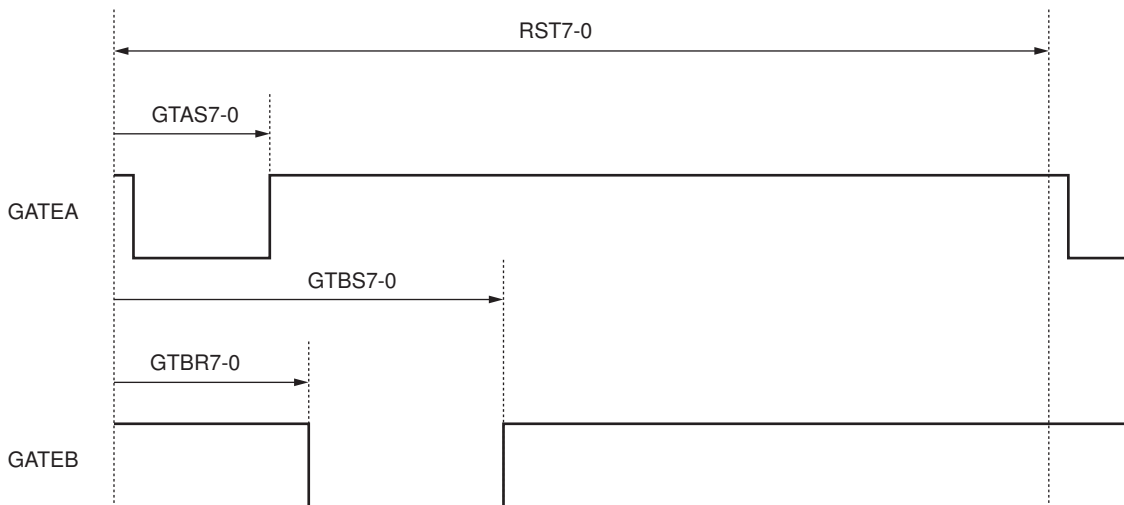

6	0	0	0	0	0	1	1	0	D7	D6	D5	D4	D3	D2	D1	D0
---	---	---	---	---	---	---	---	---	----	----	----	----	----	----	----	----

STP7 to STP0 : Specifies the number of output pulse steps with regard to DRIVE input (1 to 256). Default = 1

The setting value range is handled as the data value plus 1.

When data is input in 8-bit units (0 to 255), it is handled as an STP period of 1 to 256.

LV8491CT

7	0	0	0	0	0	1	1	1	0	0	0	0	D3	D2	D1	D0
---	---	---	---	---	---	---	---	---	---	---	---	---	----	----	----	----

INITMOV7 to INITMOV4 : Sets the number of swing back of the initialization sequence to be performed (16 to 256). Default = 16

D3	D2	D1	D0	INIT7 to 4	16 to 256
0	0	0	0	0	16
0	0	0	1	1	32
0	0	1	0	2	48
0	0	1	1	3	64
0	1	0	0	4	80
0	1	0	1	5	96
0	1	1	0	6	112
0	1	1	1	7	128
1	0	0	0	8	144
1	0	0	1	9	160
1	0	1	0	10	176
1	0	1	1	11	192
1	1	0	0	12	208
1	1	0	1	13	224
1	1	1	0	14	240
1	1	1	1	15	256

8	0	0	0	0	1	0	0	0	0	0	D5	D4	D3	D2	D1	D0
---	---	---	---	---	---	---	---	---	---	---	----	----	----	----	----	----

NRPUL15 to NRPUL10: 0 to 63. Default = 0

Specifies the total number of output periods of the NR1 to NR5 drive waveforms during rise operation when multiple drive waveforms are output continuously during actuator operation.

When set to 0, NR drive waveforms are not output during rise operation, and normal output operation is performed.

9	0	0	0	0	1	0	0	1	0	0	D5	D4	D3	D2	D1	D0
---	---	---	---	---	---	---	---	---	---	---	----	----	----	----	----	----

NRP-A5 to NRP-A0: 0 to 63. Default = 0

This register specifies the first switching timing of the rise NR drive waveform.

It determines the number of NR1 waveform output periods during rise operation.

10	0	0	0	0	1	0	1	0	0	0	D5	D4	D3	D2	D1	D0
----	---	---	---	---	---	---	---	---	---	---	----	----	----	----	----	----

NRP-B5 to NRP-B0: 0 to 63. Default = 0

This register specifies the second switching timing of the rise NR drive waveform.

The NR2 waveform is output for a number of periods equal to the difference between NRP-A and NRP-B.

11	0	0	0	0	1	0	1	1	0	0	D5	D4	D3	D2	D1	D0
----	---	---	---	---	---	---	---	---	---	---	----	----	----	----	----	----

NRP-C5 to NRP-C0: 0 to 63. Default = 0

This register specifies the third switching timing of the rise NR drive waveform.

The NR3 waveform is output for a number of periods equal to the difference between NRP-B and NRP-C.

LV8491CT

12	0	0	0	0	1	1	0	0	0	0	D5	D4	D3	D2	D1	D0
----	---	---	---	---	---	---	---	---	---	---	----	----	----	----	----	----

NRP-D5 to NRP-D0: 0 to 63. Default = 0

This register specifies the fourth switching timing of the rise NR drive waveform.

The NR4 waveform is output for a number of periods equal to the difference between NRP-C and NRP-D, and the NR5 waveform is output for a number of periods equal to the difference between NRP-D and NRPUL1.

When setting the rise NR drive waveforms, the setting values should in principle satisfy the following relationship.

$$\text{NRP-A} \leq \text{NRP-B} \leq \text{NRP-C} \leq \text{NRP-D}$$

(When this relationship is not satisfied, unintended drive waveforms may be output. However, this will not result in IC breakdowns or other damage.)

13	0	0	0	0	1	1	0	1	0	0	D5	D4	D3	D2	D1	D0
----	---	---	---	---	---	---	---	---	---	---	----	----	----	----	----	----

NRPUL25 to NRPUL20: 0 to 63. Default = 0

Specifies the total number of output periods of the NR5 to NR1 drive waveforms during fall operation, when multiple drive waveforms are output continuously during actuator operation.

When set to 0, NR drive waveforms are not output during fall operation, and operation stops.

14	0	0	0	0	1	1	1	0	0	0	D5	D4	D3	D2	D1	D0
----	---	---	---	---	---	---	---	---	---	---	----	----	----	----	----	----

NRP-E5 to NRP-E0: 0 to 63. Default = 0

This register specifies the first switching timing of the fall NR drive waveform.

It determines the number of NR5 waveform output periods during fall operation.

15	0	0	0	0	1	1	1	1	0	0	D5	D4	D3	D2	D1	D0
----	---	---	---	---	---	---	---	---	---	---	----	----	----	----	----	----

NRP-F5 to NRP-F0: 0 to 63. Default = 0

This register specifies the second switching timing of the fall NR drive waveform.

The NR4 waveform is output for a number of periods equal to the difference between NRP-E and NRP-F.

16	0	0	0	1	0	0	0	0	0	0	D5	D4	D3	D2	D1	D0
----	---	---	---	---	---	---	---	---	---	---	----	----	----	----	----	----

NRP-G5 to NRP-G0: 0 to 63. Default = 0

This register specifies the third switching timing of the fall NR drive waveform.

The NR3 waveform is output for a number of periods equal to the difference between NRP-F and NRP-G.

17	0	0	0	1	0	0	0	1	0	0	D5	D4	D3	D2	D1	D0
----	---	---	---	---	---	---	---	---	---	---	----	----	----	----	----	----

NRP-H5 to NRP-H0: 0 to 63. Default = 0

This register specifies the fourth switching timing of the fall NR drive waveform.

The NR2 waveform is output for a number of periods equal to the difference between NRP-G and NRP-H, and the NR1 waveform is output for a number of periods equal to the difference between NRP-H and NRPUL2.

When setting the fall NR drive waveforms, the setting values should in principle satisfy the following relationship.

$$\text{NRP-E} \leq \text{NRP-F} \leq \text{NRP-G} \leq \text{NRP-H}$$

(When this relationship is not satisfied, unintended drive waveforms may be output. However, this will not result in IC breakdowns or other damage.)

LV8491CT

18	0	0	0	1	0	0	1	0	D7	D6	D5	D4	D3	D2	D1	D0
NR1GTBR7 to NR1GTBR0: 0 to 255. Default = 0																
GATE_B pulse reset value for NR1 waveform																
19	0	0	0	1	0	0	1	1	D7	D6	D5	D4	D3	D2	D1	D0
NR1GTBS7 to NR1GTBS0: 0 to 255. Default = 0																
GATE_B pulse set value for NR1 waveform																
20	0	0	0	1	0	1	0	0	D7	D6	D5	D4	D3	D2	D1	D0
NR2GTBR7 to NR2GTBR0: 0 to 255. Default = 0																
GATE_B pulse reset value for NR2 waveform																
21	0	0	0	1	0	1	0	1	D7	D6	D5	D4	D3	D2	D1	D0
NR2GTBS7 to NR2GTBS0: 0 to 255. Default = 0																
GATE_B pulse set value for NR2 waveform																
22	0	0	0	1	0	1	1	0	D7	D6	D5	D4	D3	D2	D1	D0
NR3GTBR7 to NR3GTBR0: 0 to 255. Default = 0																
GATE_B pulse reset value for NR3 waveform																
23	0	0	0	1	0	1	1	1	D7	D6	D5	D4	D3	D2	D1	D0
NR3GTBS7 to NR3GTBS0: 0 to 255. Default = 0																
GATE_B pulse set value for NR3 waveform																
24	0	0	0	1	1	0	0	0	D7	D6	D5	D4	D3	D2	D1	D0
NR4GTBR7 to NR4GTBR0: 0 to 255. Default = 0																
GATE_B pulse reset value for NR4 waveform																
25	0	0	0	1	1	0	0	1	D7	D6	D5	D4	D3	D2	D1	D0
NR4GTBS7 to NR4GTBS0: 0 to 255. Default = 0																
GATE_B pulse set value for NR4 waveform																
26	0	0	0	1	1	0	1	0	D7	D6	D5	D4	D3	D2	D1	D0
NR5GTBR7 to NR5GTBR0: 0 to 255. Default = 0																
GATE_B pulse reset value for NR5 waveform																
27	0	0	0	1	1	0	1	1	D7	D6	D5	D4	D3	D2	D1	D0
NR5GTBS7 to NR5GTBS0: 0 to 255. Default = 0																
GATE_B pulse set value for NR5 waveform																
28	No register address								D7	0	0	0	0	0	0	0

READ only register line.

D7 : BUSY register Set to 1 when the IC is performing the output operation.

Set to 0 when the IC stops the output operation.

Functional Description

1 period :

One period of OUT waveform operation is equivalent to one output operation.

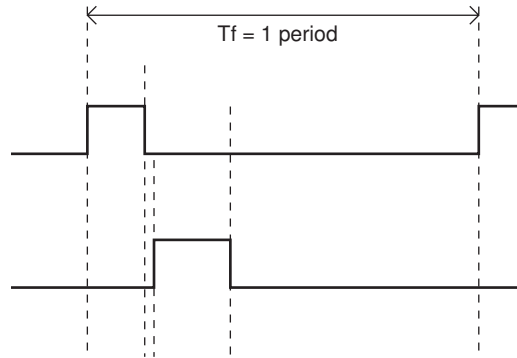

Initialization sequence (on or off and direction can be set by I²C) :

This is an internal sequence in which the actuator is moved to the initial position when the IC is started up.

Switching the value of ENIN register from 0 to 1 starts the IC.

The presence or absence of the initialization operation can be set using the initialization mode select register (INIT). If the initialization operation is specified, the direction of the initialization sequence can be set using the M/I register.

- M/I register = 0 : Initialization processing in infinity direction

The IC performs the number of operations determined by STP setting period × INIT setting times in the infinite direction, then waits for the period equivalent to STP setting period × 4 times, and performs the number of swing back operations equal to STP setting period × RET setting times in the macro direction.

- M/I register = 1 : Auto macro operation in macro direction

The IC performs the number of operations determined by STP setting period × INIT setting times in the macro direction, then waits for the period equivalent to STP setting periods × 4, and performs the number of swing back operations equal to STP period setting period × RET setting times in the infinity direction.

CLK input :

The input pin for the external CLK input that provides the reference time for generating drive waveforms.

The frequency division ratio for I²C communication can be selected from 1/4, 1/2, and 1/1.

Drive waveforms are generated by counting this frequency-divided clk pulses as the basic count unit.

The LV8491CT supports frequency range of 10MHz to 60MHz depending on the frequency division ratio and counter settings.

Register setting sequence example

- (1) Apply VCC.
- (2) Set up the register address 0x01 to 0x07 (setting up waveform and drive conditions)
- (3) Set the ENIN register to 1 (initialization startup when the initialization sequence is enabled, or IC startup).
- (4) AF operation starts (actuator operation instruction) according to the M/I and DRVPULSE settings.

I²C communication during output operation

I²C communication is possible to all registers during IC operation (during OUT output or when BUSY is high).

However, note that when drive waveform settings are changed during actuator or other operation, unintended waveforms may be output.

LV8491CT

Actuator drive waveform settings :

Configuration of piezoelectric actuator drive waveform

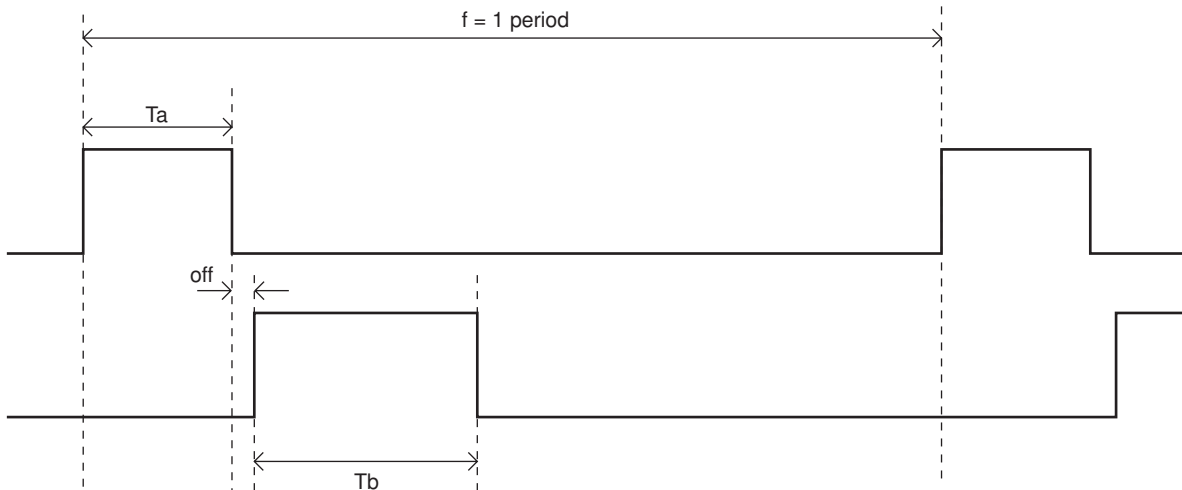

Drive parameter settings

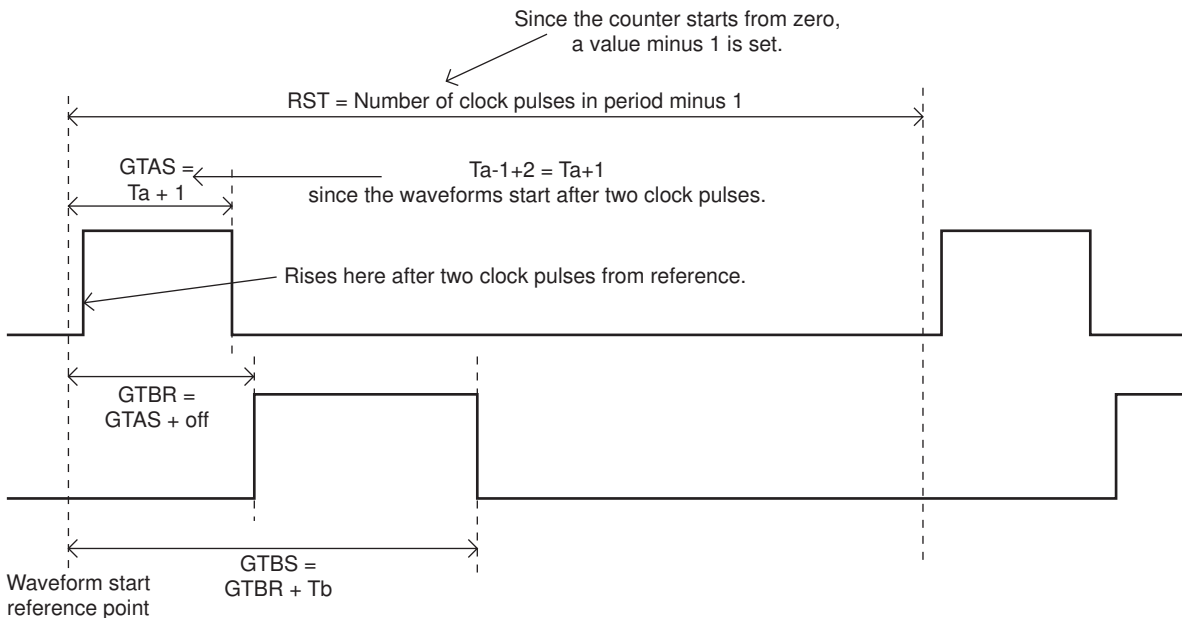

The drive waveforms are set using four parameters: RST, GTAS, GTBR and GTBS.

- RST** : Parameter determines the period, and sets the reference clock pulse count minus 1.
- GTAS** : Parameter determines the time taken for the gate signal A to the falling edge from the reference point.
Since the signal raises after two clock pulses from the reference, the T_a reference clock cycle count plus 1 is set.
- GTBR** : Parameter determines the time taken for the gate signal B to the rising edge from the reference point.
It sets the value obtained by adding the reference clock pulse count during the time from GTAS to "off."
- GTBS** : Parameter determines the time taken for the gate signal B to the falling edge from the reference point.
It sets the value obtained by adding the reference clock pulse count during the time from GTBR to "Tb."

[Example of settings] When setting reference clock to 10MHz, period to $13\mu\text{s}$, T_a to $2.0\mu\text{s}$, off to $0.3\mu\text{s}$, and T_b to $3.0\mu\text{s}$
Since the reference clock time is $0.1\mu\text{s}$:

- The period is 130 clks. → Specify 129 (RST value of $130 - 1$).
- T_a is 20 clks. → Specify 21 (GTAS value of $20 + 1$).
- off is 3 clks. → Specify 24 (GTBR value of $21 + 3$).
- T_b is 30 clks. → Specify 54 (GTBS value of $24 + 30$).

Timing charts

Enlarged view of the sequence of output signals

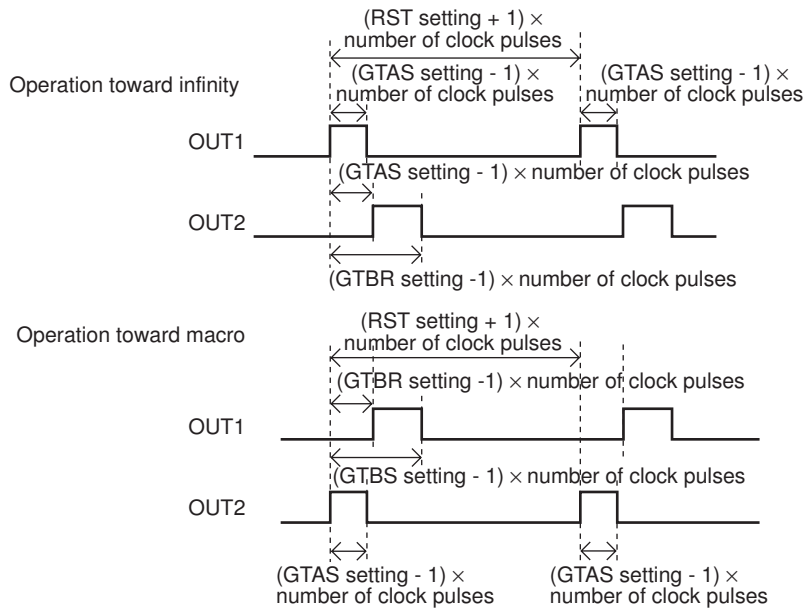

Sequence of initial setting operation (“on” or “off” can be set by the serial settings.)

When M/I register = 00 → Movement toward infinity position

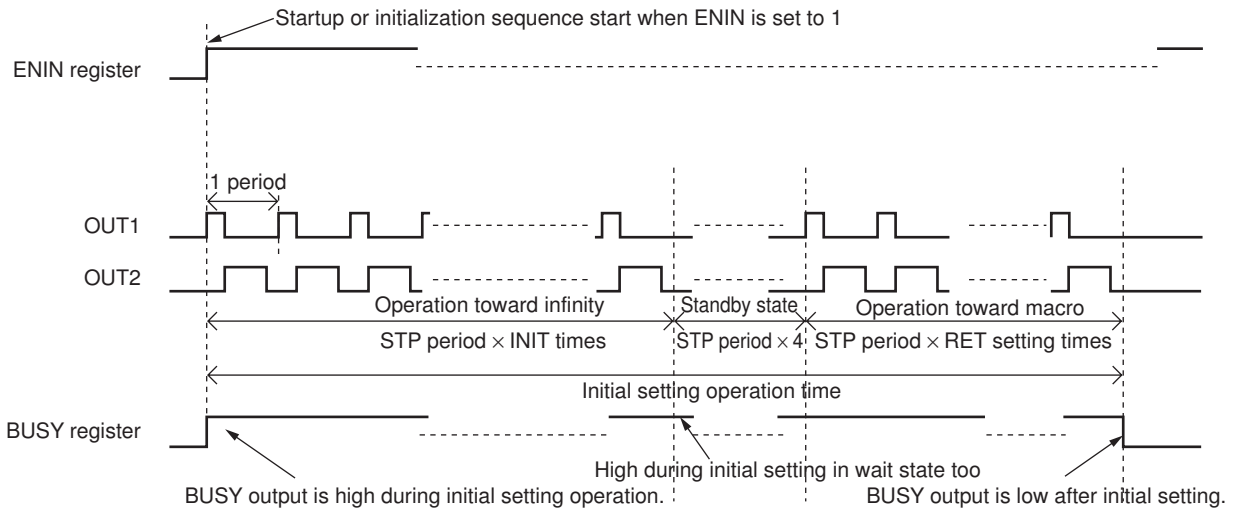

When M/I register = 01 → Movement toward macro position

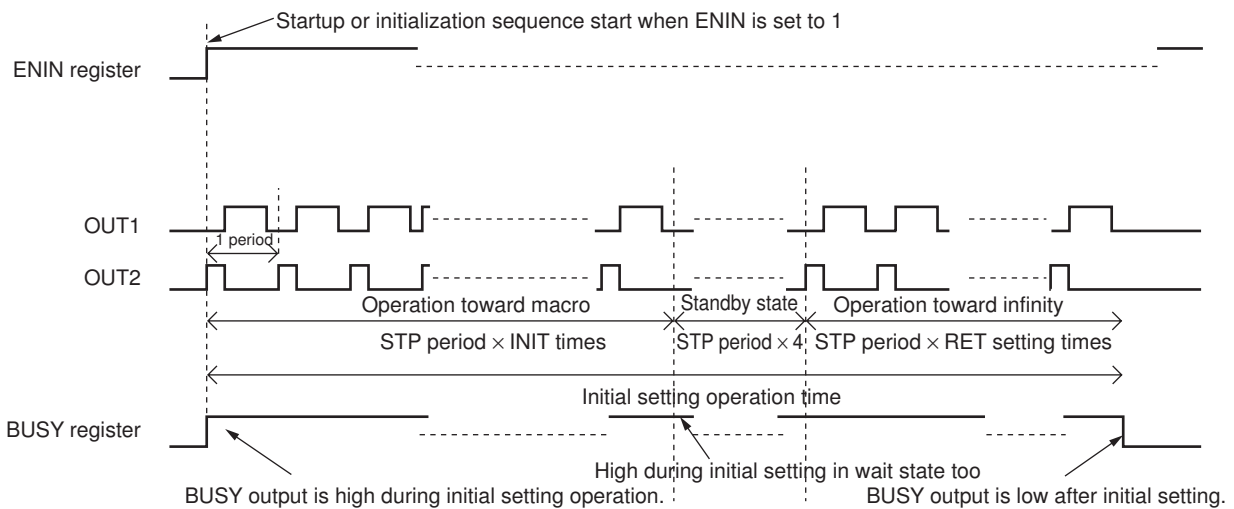

LV8491CT

Sequence of operations triggered by DRVPULSE input

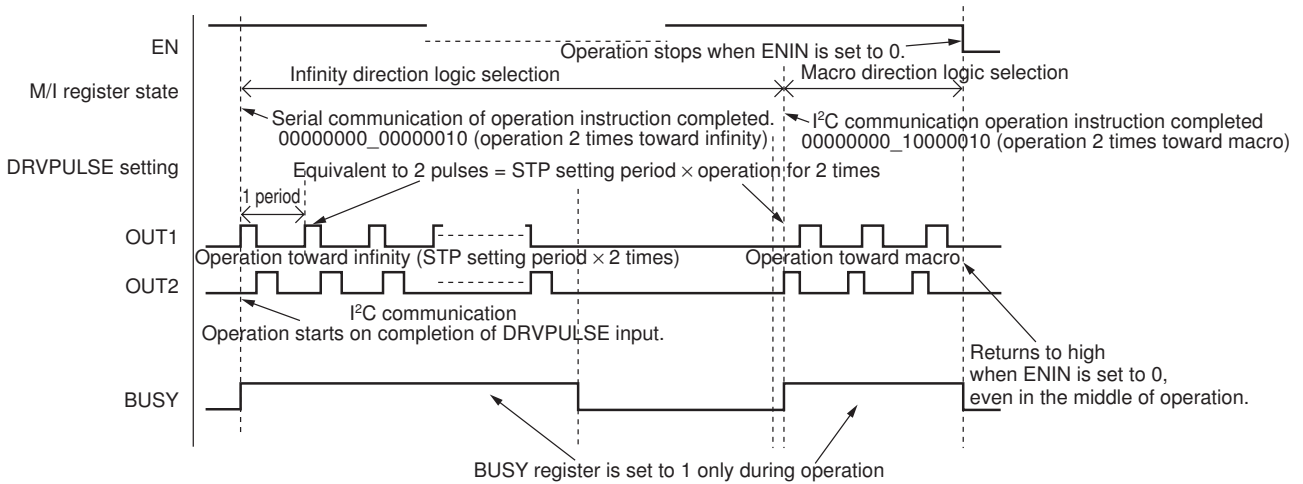

Gate setting output logic

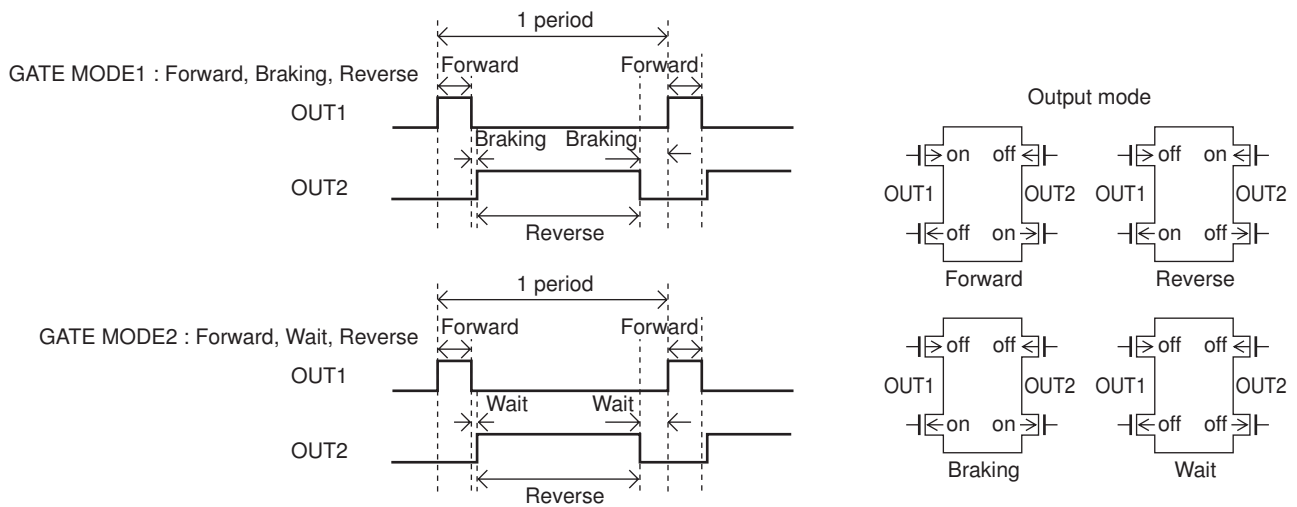

ON Semiconductor and the ON logo are registered trademarks of Semiconductor Components Industries, LLC (SCILLC). SCILLC owns the rights to a number of patents, trademarks, copyrights, trade secrets, and other intellectual property. A listing of SCILLC's product/patent coverage may be accessed at www.onsemi.com/site/pdf/Patent-Marking.pdf. SCILLC reserves the right to make changes without further notice to any products herein. SCILLC makes no warranty, representation or guarantee regarding the suitability of its products for any particular purpose, nor does SCILLC assume any liability arising out of the application or use of any product or circuit, and specifically disclaims any and all liability, including without limitation special, consequential or incidental damages. "Typical" parameters which may be provided in SCILLC data sheets and/or specifications can and do vary in different applications and actual performance may vary over time. All operating parameters, including "Typicals" must be validated for each customer application by customer's technical experts. SCILLC does not convey any license under its patent rights nor the rights of others. SCILLC products are not designed, intended, or authorized for use as components in systems intended for surgical implant into the body, or other applications intended to support or sustain life, or for any other application in which the failure of the SCILLC product could create a situation where personal injury or death may occur. Should Buyer purchase or use SCILLC products for any such unintended or unauthorized application, Buyer shall indemnify and hold SCILLC and its officers, employees, subsidiaries, affiliates, and distributors harmless against all claims, costs, damages, and expenses, and reasonable attorney fees arising out of, directly or indirectly, any claim of personal injury or death associated with such unintended or unauthorized use, even if such claim alleges that SCILLC was negligent regarding the design or manufacture of the part. SCILLC is an Equal Opportunity/Affirmative Action Employer. This literature is subject to all applicable copyright laws and is not for resale in any manner.