



SANYO Semiconductors

DATA SHEET

An ON Semiconductor Company

LC79430KNE — CMOS LSI Dot-Matrix LCD Drivers

Overview

The LC79430KNE is a large-scale dot matrix LCD common driver LSI. The LC79430KNE contains an 80-bit bidirectional shift register and is equipped with a 4-level LCD driver. The input/output pins for cascade connection can be used to further increase the IC's number of bits. The LC79430KNE can be used in conjunction with segment driver LC79401KNE (QIP100E) to drive a wide-screen LCD panel.

Features

- On-chip LCD drive circuit (80 bits)
- Display duty selection ranging from 1/64 to 1/256
- On-chip input/output pins support a further increases in bit number
- Supports externally supplied bias voltage
- On-chip 80-bit bidirectional shift register (supports 40-bit × 2 division)
- Supports single mode (80-bit shift register) and dual mode (40-bit × 2 shift register) applications
 - (1) O1 → O80 } Single mode
 - (2) O80 → O1 } Single mode
 - (3) O1 → O40 and O41 → O80 } Dual mode
 - (4) O80 → O41 and O40 → O1 } Dual mode
- All four of the shift direction selection listed above all supported
- Operating power supply voltage/operating temperature include
 - V_{DD} (Logic section) : 2.7 to 5.5V/-20 to +85°C
 - V_{DD}-V_{EE} (LCD section) : 12 to 32V/-20 to +85°C
- CMOS process
- 100-pin flat plastic package (QIP100E)

■ Any and all SANYO Semiconductor Co.,Ltd. products described or contained herein are, with regard to "standard application", intended for the use as general electronics equipment. The products mentioned herein shall not be intended for use for any "special application" (medical equipment whose purpose is to sustain life, aerospace instrument, nuclear control device, burning appliances, transportation machine, traffic signal system, safety equipment etc.) that shall require extremely high level of reliability and can directly threaten human lives in case of failure or malfunction of the product or may cause harm to human bodies, nor shall they grant any guarantee thereof. If you should intend to use our products for new introduction or other application different from current conditions on the usage of automotive device, communication device, office equipment, industrial equipment etc. , please consult with us about usage condition (temperature, operation time etc.) prior to the intended use. If there is no consultation or inquiry before the intended use, our customer shall be solely responsible for the use.

■ Specifications of any and all SANYO Semiconductor Co.,Ltd. products described or contained herein stipulate the performance, characteristics, and functions of the described products in the independent state, and are not guarantees of the performance, characteristics, and functions of the described products as mounted in the customer's products or equipment. To verify symptoms and states that cannot be evaluated in an independent device, the customer should always evaluate and test devices mounted in the customer's products or equipment.

SANYO Semiconductor Co., Ltd.

<http://www.sanyosemi.com/en/network/>

LC79430KNE

Specifications

Absolute Maximum Ratings at $T_a = 25 \pm 2^\circ\text{C}$, $V_{SS} = 0\text{V}$

Parameter	Symbol	Conditions	Ratings	unit
Maximum supply voltage (Logic)	V_{DD} max		-0.3 to +7.0	V
Maximum supply voltage (LCD)	$V_{DD}-V_{EE}$ max	*1	0 to 35	V
Maximum input voltage	V_I max		-0.3 to $V_{DD}+0.3$	V
Storage temperature	Tstg		-40 to +125	$^\circ\text{C}$

Note *1 The following relations between elements should be maintained: $V_{DD} \geq V_1 > V_2 > V_5 > V_{EE}$, $V_{DD}-V_2 \leq 7\text{V}$, $V_5-V_{EE} \leq 7\text{V}$

Allowable Operating Ranges at $T_a = -20$ to $+85^\circ\text{C}$, $V_{SS} = 0\text{V}$

Parameter	Symbol	Conditions	min	typ	max	unit
Supply voltage (Logic)	V_{DD}		2.7		5.5	V
Supply voltage (LCD)	$V_{DD}-V_{EE}$	*2, 3	12		32	V
Input high level voltage	V_{IH}	DIO1, DIO80, CP, M, DMIN, MODE, RS/LS, DISPOFF	$0.8V_{DD}$			V
Input low level voltage	V_{IL}	DIO1, DIO80, CP, M, DMIN, MODE, RS/LS, DISPOFF			$0.2V_{DD}$	V
CP Shift clock	f_{CP}	CP			1	MHz
CP pulse width	t_{WC}	CP	63			ns
Setup time	t_{SETUP}	DIO1 \rightarrow CP, DIO80 \rightarrow CP, DMIN \rightarrow CP	100			ns
Hold time	t_{HOLD}	DIO1 \rightarrow CP, DIO80 \rightarrow CP, DMIN \rightarrow CP	100			ns
CP rise time	t_R	CP			50	ns
CP fall time	t_F	CP			50	ns

Note *2 The following relations between elements should be maintained: $V_{DD} \geq V_1 > V_2 > V_5 > V_{EE}$, $V_{DD}-V_2 \leq 7\text{V}$, $V_5-V_{EE} \leq 7\text{V}$

*3 When the power supply is turned on, power to the LCD driver is turned on after or simultaneously with the turning on of the logic section's power supply. When the power supply is turned off, the logic power supply is turned off after or at the same time the LCD driver power supply is turned off.

Electrical Characteristics at $T_a = 25 \pm 2^\circ\text{C}$, $V_{DD} = 2.7$ to 5.5V

Parameter	Symbol	Conditions	min	typ	max	unit
Input high level current	I_{IH}	$V_{IN}=V_{DD}$, $V_{DD}=5.5\text{V}$, DIO1, DIO80, CP, M, DMIN, MODE, RS/LS, DISPOFF			1	μA
Input low level current	I_{IL}	$V_{IN}=V_{SS}$, $V_{DD}=5.5\text{V}$, DIO1, DIO80, CP, M, DMIN, MODE, RS/LS, DISPOFF	-1			μA
Output high level voltage	V_{OH}	$I_{OH}=-0.4\text{mA}$, DIO1, DIO80	$V_{DD}-0.4$			V
Output low level voltage	V_{OL}	$I_{OL}=0.4\text{mA}$, DIO1, DIO80			0.4	V
Driver on resistance	$R_{ON(1)}$	$V_{DD}-V_{EE}=30\text{V}$, $ V_{DE}-V_O =0.5\text{V}$, $V_{DD}=4.5\text{V}$, O1 to O80 *4			1.0	$\text{k}\Omega$
	$R_{ON(2)}$	$V_{DD}-V_{EE}=20\text{V}$, $ V_{DE}-V_O =0.5\text{V}$, $V_{DD}=4.5\text{V}$, O1 to O80 *4			1.0	$\text{k}\Omega$
Consumable current drain (1)	I_{SS}	$V_{DD}-V_{EE}=30\text{V}$, CP=14kHz no-load, $V_{DD}=5.5\text{V}$; V_{SS}			100	μA
Consumable current drain (2)	I_{EE}	$V_{DD}-V_{EE}=30\text{V}$, CP=14kHz no-load, $V_{DD}=5.5\text{V}$; V_{EE}			100	μA
Input capacitance	CI	f=1MHz; CP		8		pF

Note *4 $V_{DE} = V_1$ or V_2 or V_5 or V_{EE} , $V_1 = V_{DD}$, $V_2 = 16/17 (V_{DD}-V_{EE})$, $V_5 = 1/17 (V_{DD}-V_{EE})$

Switching Characteristics at $T_a = 25 \pm 2^\circ\text{C}$, $V_{SS} = 0\text{V}$, $V_{DD} = 2.7$ to 5.5V

Parameter	Symbol	Conditions	min	typ	max	unit
Output delay time	t_{PLH}	CL=15pF; CP \rightarrow DIO1, CP \rightarrow DIO80			250	ns
	t_{PHL}	CL=15pF; CP \rightarrow DIO1, CP \rightarrow DIO80			250	ns

LC79430KNE

Equivalent Circuit Block Diagram

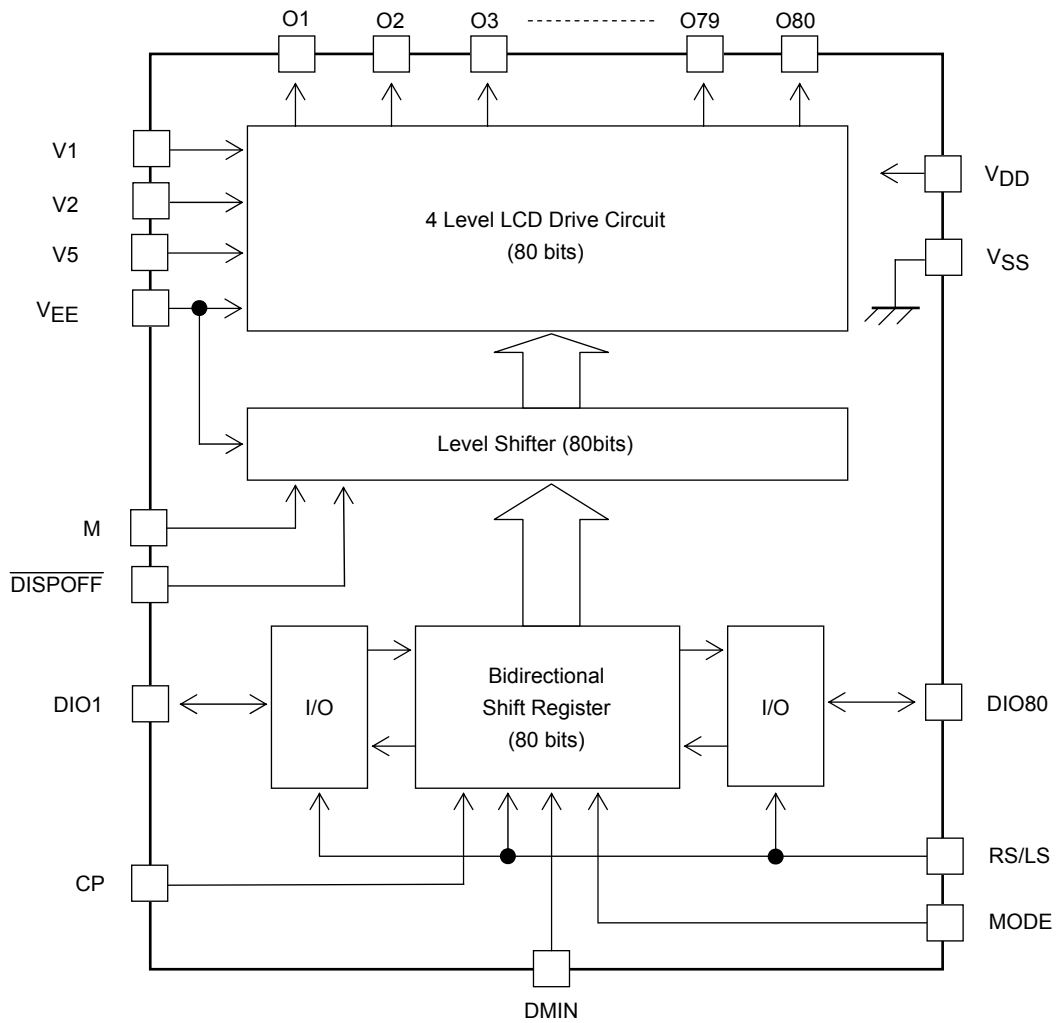

LC79430KNE

Pin Function

Pin No	Symbol	I/O	Function																														
90	V _{DD}	Supply	V _{DD} -V _{SS} : Logic power supply V _{DD} -V _{EE} : LCD drive circuit power supply																														
92	V _{SS}																																
84	V _{EE}																																
87	V1	Supply	LCD drive level power supply V1, V _{EE} : Selected level V2, V5 : Unselected level																														
86	V2																																
85	V5																																
96	CP	I	Bidirectional shift register shift clock (falling edge trigger)																														
98 82	DIO1 DIO80	I/O I/O	<table border="1" style="width: 100%; border-collapse: collapse;"> <thead> <tr> <th style="width: 15%;">MODE</th> <th style="width: 15%;">RS/LS</th> <th style="width: 20%;">Data Transfer Direction</th> <th style="width: 10%;">DIO1</th> <th style="width: 10%;">DIO80</th> <th style="width: 10%;">DMIN</th> </tr> </thead> <tbody> <tr> <td rowspan="2" style="text-align: center;">L (Single)</td> <td>L (Shift right)</td> <td style="text-align: center;">O1 → O80</td> <td style="text-align: center;">IN</td> <td style="text-align: center;">OUT</td> <td style="text-align: center;">*</td> </tr> <tr> <td>H (Shift left)</td> <td style="text-align: center;">O80 → O1</td> <td style="text-align: center;">OUT</td> <td style="text-align: center;">IN</td> <td style="text-align: center;">*</td> </tr> <tr> <td rowspan="4" style="text-align: center;">H (Dual)</td> <td rowspan="2" style="text-align: center;">L (Shift right)</td> <td style="text-align: center;">O1 → O40</td> <td rowspan="2" style="text-align: center;">IN</td> <td rowspan="2" style="text-align: center;">OUT</td> <td rowspan="2" style="text-align: center;">IN</td> </tr> <tr> <td style="text-align: center;">O41 → O80</td> </tr> <tr> <td rowspan="2" style="text-align: center;">H (Shift left)</td> <td style="text-align: center;">O80 → O41</td> <td rowspan="2" style="text-align: center;">OUT</td> <td rowspan="2" style="text-align: center;">IN</td> <td rowspan="2" style="text-align: center;">IN</td> </tr> <tr> <td style="text-align: center;">O40 → O1</td> </tr> </tbody> </table> <p style="font-size: small;">* Don't care (May be set to either "H" or "L")</p>	MODE	RS/LS	Data Transfer Direction	DIO1	DIO80	DMIN	L (Single)	L (Shift right)	O1 → O80	IN	OUT	*	H (Shift left)	O80 → O1	OUT	IN	*	H (Dual)	L (Shift right)	O1 → O40	IN	OUT	IN	O41 → O80	H (Shift left)	O80 → O41	OUT	IN	IN	O40 → O1
MODE	RS/LS	Data Transfer Direction	DIO1	DIO80	DMIN																												
L (Single)	L (Shift right)	O1 → O80	IN	OUT	*																												
	H (Shift left)	O80 → O1	OUT	IN	*																												
H (Dual)	L (Shift right)	O1 → O40	IN	OUT	IN																												
		O41 → O80																															
	H (Shift left)	O80 → O41	OUT	IN	IN																												
		O40 → O1																															
94	M	I	LCD drive output alternation signal																														
89	$\overline{\text{DISPOFF}}$	I	O1 to O80 output controlling input pins.																														
1 ⋮ 80	O1 ⋮ O80	O	<p>LCD drive outputs The output levels are determined by the combination of the output the data, The M signal, and the $\overline{\text{DISPOFF}}$ pin as shown in the table.</p> <table border="1" style="width: 100%; border-collapse: collapse;"> <thead> <tr> <th style="width: 15%;">M</th> <th style="width: 15%;">Data</th> <th style="width: 15%;">$\overline{\text{DISPOFF}}$</th> <th style="width: 15%;">Output</th> </tr> </thead> <tbody> <tr> <td style="text-align: center;">L</td> <td style="text-align: center;">L</td> <td style="text-align: center;">H</td> <td style="text-align: center;">V2</td> </tr> <tr> <td style="text-align: center;">L</td> <td style="text-align: center;">H</td> <td style="text-align: center;">H</td> <td style="text-align: center;">V_{EE}</td> </tr> <tr> <td style="text-align: center;">H</td> <td style="text-align: center;">L</td> <td style="text-align: center;">H</td> <td style="text-align: center;">V5</td> </tr> <tr> <td style="text-align: center;">H</td> <td style="text-align: center;">H</td> <td style="text-align: center;">H</td> <td style="text-align: center;">V1</td> </tr> <tr> <td style="text-align: center;">*</td> <td style="text-align: center;">*</td> <td style="text-align: center;">L</td> <td style="text-align: center;">V1</td> </tr> </tbody> </table> <p style="font-size: small;">* Don't care (May be set to either "H" or "L")</p>	M	Data	$\overline{\text{DISPOFF}}$	Output	L	L	H	V2	L	H	H	V _{EE}	H	L	H	V5	H	H	H	V1	*	*	L	V1						
M	Data	$\overline{\text{DISPOFF}}$	Output																														
L	L	H	V2																														
L	H	H	V _{EE}																														
H	L	H	V5																														
H	H	H	V1																														
*	*	L	V1																														
81 83 88 93 99 100	NC	-	Must be left open.																														

LC79430KNE

Application Example (LC79401KNE/LC79430KNE)

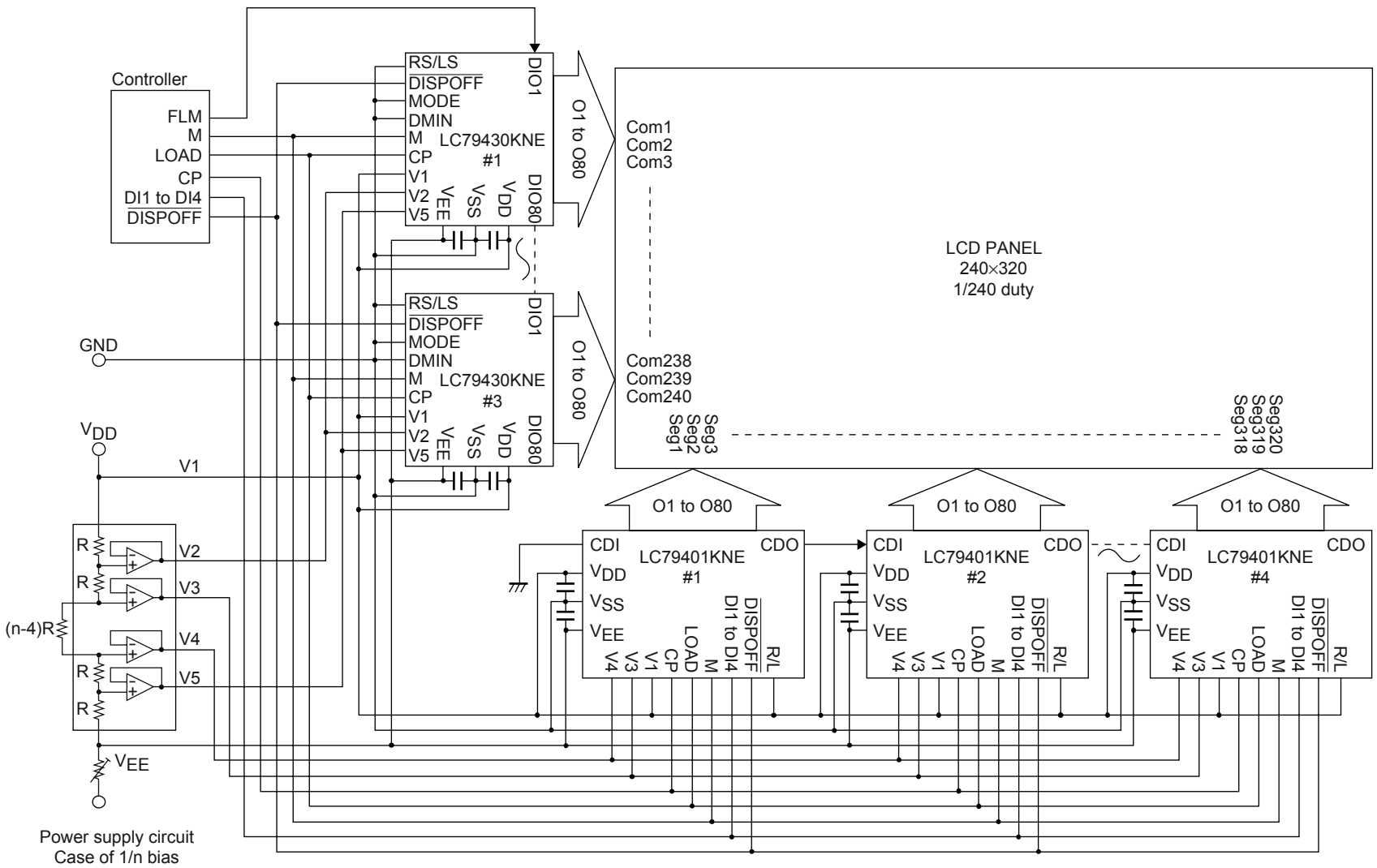

Switching Characteristics Diagram

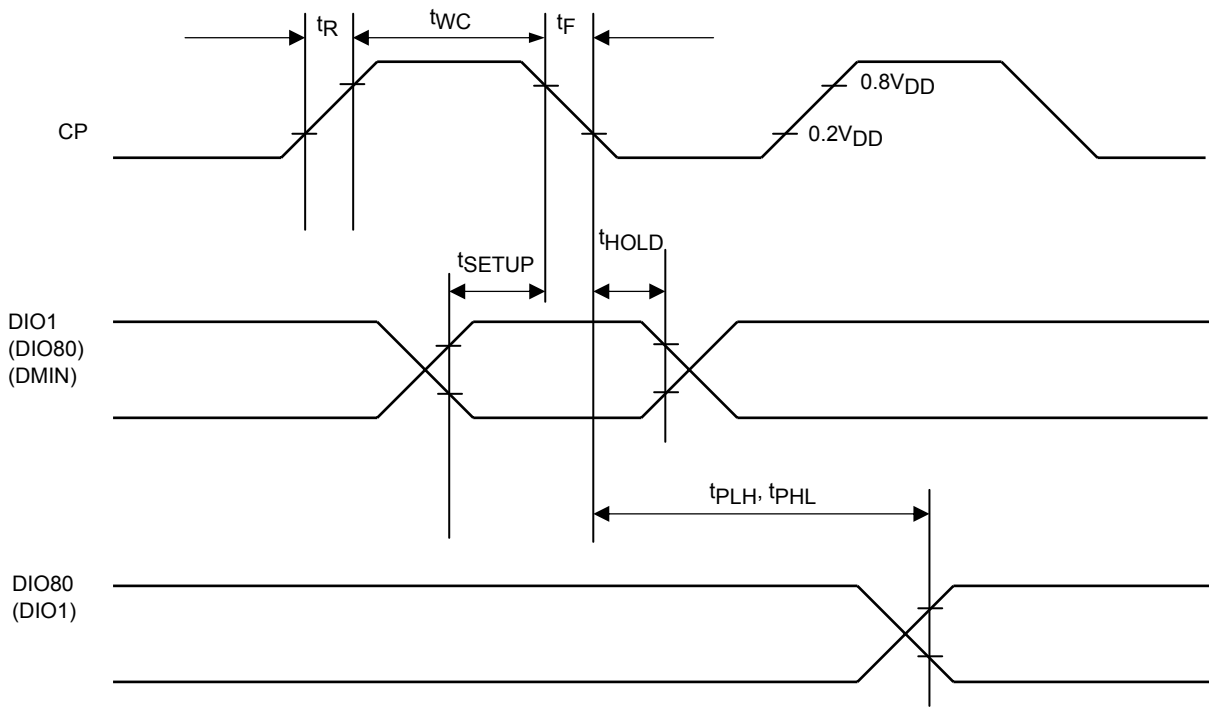

- SANYO Semiconductor Co.,Ltd. assumes no responsibility for equipment failures that result from using products at values that exceed, even momentarily, rated values (such as maximum ratings, operating condition ranges, or other parameters) listed in products specifications of any and all SANYO Semiconductor Co.,Ltd. products described or contained herein.
- Regarding monolithic semiconductors, if you should intend to use this IC continuously under high temperature, high current, high voltage, or drastic temperature change, even if it is used within the range of absolute maximum ratings or operating conditions, there is a possibility of decrease reliability. Please contact us for a confirmation.
- SANYO Semiconductor Co.,Ltd. strives to supply high-quality high-reliability products, however, any and all semiconductor products fail or malfunction with some probability. It is possible that these probabilistic failures or malfunction could give rise to accidents or events that could endanger human lives, trouble that could give rise to smoke or fire, or accidents that could cause damage to other property. When designing equipment, adopt safety measures so that these kinds of accidents or events cannot occur. Such measures include but are not limited to protective circuits and error prevention circuits for safe design, redundant design, and structural design.
- In the event that any or all SANYO Semiconductor Co.,Ltd. products described or contained herein are controlled under any of applicable local export control laws and regulations, such products may require the export license from the authorities concerned in accordance with the above law.
- No part of this publication may be reproduced or transmitted in any form or by any means, electronic or mechanical, including photocopying and recording, or any information storage or retrieval system, or otherwise, without the prior written consent of SANYO Semiconductor Co.,Ltd.
- Any and all information described or contained herein are subject to change without notice due to product/technology improvement, etc. When designing equipment, refer to the "Delivery Specification" for the SANYO Semiconductor Co.,Ltd. product that you intend to use.
- Upon using the technical information or products described herein, neither warranty nor license shall be granted with regard to intellectual property rights or any other rights of SANYO Semiconductor Co.,Ltd. or any third party. SANYO Semiconductor Co.,Ltd. shall not be liable for any claim or suits with regard to a third party's intellectual property rights which has resulted from the use of the technical information and products mentioned above.

This catalog provides information as of September, 2012. Specifications and information herein are subject to change without notice.