



SANYO Semiconductors

DATA SHEET

An ON Semiconductor Company

LV5236V — Bi-CMOS IC 24-channel LED Driver

Overview

The LV5236V is a 24-channel LED driver IC that is capable of switching between constant-current output and open drain output. It enables 3-wire serial bus control (address designation)/I²C serial bus control to be set arbitrarily using an external pin. Also possible are 24-channel LED ON/OFF control and the setting of the PWM luminance in 256 steps. The device also has a built-in fade-in/fade-out function. Up to 32 driver ICs can be connected using the slave address setting pins.

Features

- 24-channel output constant-current LED driver/open drain output LED driver (selected by using an external pin)
 - Supports separate ON/OFF setting for each LED output, high withstand voltage (V_{OUT}<42V)
 - In the constant-current mode (OUTSCT: L), the reference current is set by the value of resistor connected to the external pin (RT1).
 - Built-in D/A (5 bits) for switching current level ... 0.96mA to 30.7mA (RGB drive)
 - Constant current (I_O max=50mA) for full-color LEDs × 24 channels
 - In the open drain mode (OUTSCT: M), high current drive (I_O max=100mA) × 24 channels
 - In the constant-current mode (OUTSCT: H)
 - Only RGB6 is open drain (I_O max=100mA)
- Luminance adjustment using internal PWM control (256 steps)
 - 8-bit PWM luminance dimming (0% to 99.6%)
 - 8-phase PWM
- Fade-in/fade-out function (PWM control priority), supporting synchronous connection
 - Supports separate fade ON/OFF for each LED output (fade time common for all channels)
 - Interrupt control possible for fade function
- Selection of 3-wire/I²C serial bus control signals enabled (switching using an external pin)
 - Slave addressing (5 bits, connection of up to 32 driver ICs possible)
- Low current consumption
- Output malfunction protection circuits (thermal protection function, UVLO detection protection function)

■ Any and all SANYO Semiconductor Co.,Ltd. products described or contained herein are, with regard to "standard application", intended for the use as general electronics equipment. The products mentioned herein shall not be intended for use for any "special application" (medical equipment whose purpose is to sustain life, aerospace instrument, nuclear control device, burning appliances, transportation machine, traffic signal system, safety equipment etc.) that shall require extremely high level of reliability and can directly threaten human lives in case of failure or malfunction of the product or may cause harm to human bodies, nor shall they grant any guarantee thereof. If you should intend to use our products for new introduction or other application different from current conditions on the usage of automotive device, communication device, office equipment, industrial equipment etc. , please consult with us about usage condition (temperature, operation time etc.) prior to the intended use. If there is no consultation or inquiry before the intended use, our customer shall be solely responsible for the use.

■ Specifications of any and all SANYO Semiconductor Co.,Ltd. products described or contained herein stipulate the performance, characteristics, and functions of the described products in the independent state, and are not guarantees of the performance, characteristics, and functions of the described products as mounted in the customer's products or equipment. To verify symptoms and states that cannot be evaluated in an independent device, the customer should always evaluate and test devices mounted in the customer's products or equipment.

SANYO Semiconductor Co., Ltd.

<http://semicon.sanyo.com/en/network>

LV5236V

Specifications

Maximum Ratings at $T_a = 25^\circ\text{C}$

Parameter	Symbol	Conditions	Ratings	Unit
Maximum supply voltage	V_{CC} max		6	V
Output voltage	V_O max	LED off	42	V
Output current	I_O max		100	mA
Allowable power dissipation	P_d max	$T_a \leq 25^\circ\text{C}^*$	1.36	W
Operating temperature	T_{opr}		-25 to +75	$^\circ\text{C}$
Storage temperature	T_{stg}		-40 to +125	$^\circ\text{C}$

* Specified board : 114.3mm × 76.1mm × 1.6mm, glass epoxy board. Exposed Die-pad area is not a substrate mounting.

[Warning]: If you should intend to use this IC continuously under high temperature, high current, high voltage, or drastic temperature change, even if it is used within the range of absolute maximum ratings or operating conditions, there is a possibility of decrease reliability. Please contact us for a confirmation.

Operating Conditions at $T_a = 25^\circ\text{C}$

Parameter	Symbol	Conditions	Ratings	Unit
Recommended supply voltage	V_{CC}	SV_{CC}	5.0	V
Operating supply voltage range	V_{CC} op	SV_{CC}	4.5 to 5.5	V

Electrical Characteristics at $T_a = 25^\circ\text{C}$, $V_{CC} = 5.0\text{V}$

Parameter	Symbol	Conditions	Ratings			Unit
			min	typ	max	
Consumption current	I_{CC2}	LED off		5	7	mA
Oscillator frequency	F_{osc}		900	1000	1100	kHz
Reference current pin voltage	V_{RT}	$RT1=22k\Omega$	0.92	0.98	1.04	V
MAX output current	ΔI_L	$V_O=0.7$ to 4.0V (Same channel line regulation)	-10			%
Between bits output current	ΔI_{OL}	$I_O=30.7\text{mA}$ (Between bits pairing characteristics)			5	%
Maximum LED driver output current 1	I_{MAX1}	LED OUTSCT= L	28.8	30.7	32.6	mA
LED output on resistance 1	R_{on1}	LED1, LED2, LED3, LED4, LED5, LED7, LED8 ($I_O = 100\text{mA}$)		11	22	Ω
LED output on resistance 2	R_{on2}	LED6 ($I_O = 100\text{mA}$)		4	10	Ω
OFF leak current	I_{leak}	LED OFF			10	μA
Driver output malfunction protection voltage	V_t	SV_{CC}	2.58	2.70	2.82	V

Control circuit at $T_a = 25^\circ\text{C}$, $V_{CC} = 5.0\text{V}$

Parameter	Symbol	Conditions	Ratings			Unit
			min	typ	max	
H level 1	V_{H1}	Input H level OUTSCT	4.7		5	V
M level 1	V_{M1}	Input M level OUTSCT	2		3.3	V
L level 1	V_{L1}	Input L level OUTSCT	-0.2		0.3	V
H level 2	V_{H2}	Input H level CTLSCT	$0.7 \times V_{CC}$		V_{CC}	V
L level 2	V_{L2}	Input L level CTLSCT	-0.2		0.3	V
H level 3	V_{H3}	Input H level RESET	$0.8 \times V_{CC}$		V_{CC}	V
L level 3	V_{L3}	Input L level RESET	-0.2		$0.2 \times V_{CC}$	V
H level 4	V_{H4}	Input H level SCLK, SDATA, SDEN	$0.8 \times V_{CC}$		V_{CC}	V
L level 4	V_{L4}	Input L level SCLK, SDATA, SDEN	-0.2		$0.2 \times V_{CC}$	V
H level 5	V_{H7}	Input H level A0 to A4	$0.7 \times V_{CC}$		V_{CC}	V
L level 5	V_{L7}	Input L level A0 to A4	-0.2		0.3	V

LV5236V

Package Dimensions

unit : mm (typ)

3285A

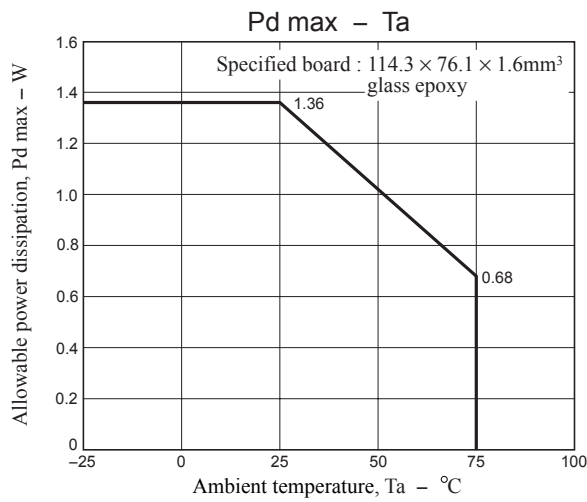
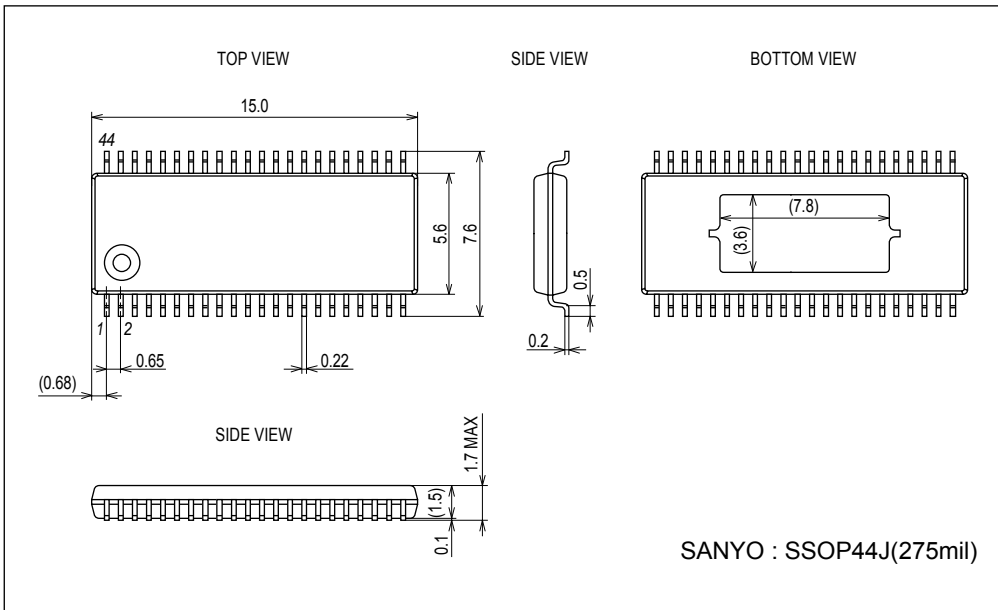

Pin Assignment

44	43	42	41	40	39	38	37	36	35	34	33	32	31	30	29	28	27	26	25	24	23
OSC_OUT	OUTSCT	CT	RT1	RESET	TEST	SGND	CTLSCT	LEDB8	LEDB7	LEDB6	LEDB5	PGND3	LEDB4	LEDB3	LEDB2	LEDB1	A4	A3	A2	A1	A0
SVCC	SCLK	SDATA	SDEN	LEDR1	LEDR2	LEDR3	LEDR4	PGND1	LEDR5	LEDR6	LEDR7	LEDR8	LEDG1	LEDG2	LEDG3	LEDG4	PGND2	LEDG5	LEDG6	LEDG7	LEDG8
1	2	3	4	5	6	7	8	9	10	11	12	13	14	15	16	17	18	19	20	21	22

Top view

LV5236V

Pin Descriptions

Pin No.	Pin name	I/O	Description
1	SVCC	-	Power supply pin
2	SCLK	I	Serial clock signal input pin
3	SDATA	I	Serial data signal input pin
4	SDEN	I	Serial enable signal input pin
5	LEDR1	O	LEDR1 output pin
6	LEDR2	O	LEDR2 output pin
7	LEDR3	O	LEDR3 output pin
8	LEDR4	O	LEDR4 output pin
9	PGND1	-	GND pin dedicated for LED driver
10	LEDR5	O	LEDR5 output pin
11	LEDR6	O	LEDR6 output pin
12	LEDR7	O	LEDR7 output pin
13	LEDR8	O	LEDR8 output pin
14	LEDG1	O	LEDG1 output pin
15	LEDG2	O	LEDG2 output pin
16	LEDG3	O	LEDG3 output pin
17	LEDG4	O	LEDG4 output pin
18	PGND2	-	GND pin dedicated for LED driver
19	LEDG5	O	LEDG5 output pin
20	LEDG6	O	LEDG6 output pin
21	LEDG7	O	LEDG7 output pin
22	LEDG8	O	LEDG8 output pin
23	A0	I	Slave address input pin A0
24	A1	I	Slave address input pin A1
25	A2	I	Slave address input pin A2
26	A3	I	Slave address input pin A3
27	A4	I	Slave address input pin A4
28	LEDB1	O	LEDB1 output pin
29	LEDB2	O	LEDB2 output pin
30	LEDB3	O	LEDB3 output pin
31	LEDB4	O	LEDB4 output pin
32	PGND3	-	GND pin dedicated for LED driver
33	LEDB5	O	LEDB5 output pin
34	LEDB6	O	LEDB6 output pin
35	LEDB7	O	LEDB7 output pin
36	LEDB8	O	LEDB8 output pin
37	CTLST	I	3-wire serial bus/I ² C serial bus selecting control pin (L: 3-wire serial, H: I ² C)
38	SGND	-	Analog circuit GND pin
39	TEST	I	Test pin (connected to GND)
40	RESET	I	Reset signal input pin
41	RT1	O	LED current setting resistor connection pin 1
42	CT	O	Oscillation frequency setting capacitor connection pin
43	OUTSCT	I	Output type switching control pin L: Constant-current output M (terminal OPEN): Open drain output H: Constant output, only RGB6 is open drain output
44	OSC_OUT	O	Oscillator output pin (synchronous connection)

Continued on next page.

LV5236V

Continued from preceding page.

OUTSCT Settings

	LED Driver Output Pin	
OUTSCT pin	LED1, LED2, LED3, LED4, LED5, LED7, LED8	LED6
L=-0.2 to 0.3V	Constant current output Built-in current value switching D/A (5 bits) 0.96mA to 30.7mA, RT1=22kΩ (f=1MHz)	Constant current output Built-in current value switching D/A (5 bits) 0.96mA to 30.7mA, RT1=22kΩ (f=1MHz)
M=2.0 to 3.3V (terminal OPEN)	Open drain output Current value is determined by external limiting resistor. R _{ON} =11Ω	Open drain output Current value is determined by external limiting resistor. R _{ON} =4Ω
H=4.7 to 5.0V	Constant current output Built-in current value switching D/A (5 bits) 0.96mA to 30.7mA, RT1=22kΩ (f=1MHz)	Open drain output Current value is determined by external limiting resistor. R _{ON} =4Ω

Block Diagram

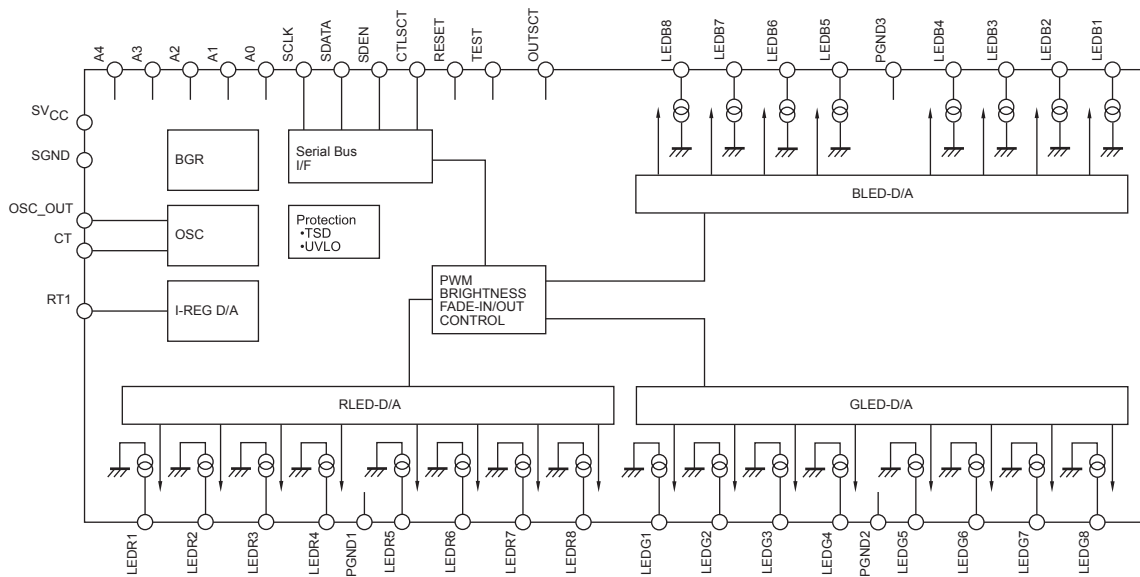

Pin Functions

Pin No.	Pin Name	Pin function	Equivalent Circuit
1	SVCC	Power supply pin	
2	SCLK	Serial clock signal input pin	
3	SDATA	Serial data signal input pin	
4	SDEN	Serial enable signal input pin	
23	A0	Slave address setting pin A0	
24	A1	Slave address setting pin A1	
25	A2	Slave address setting pin A2	
26	A3	Slave address setting pin A3	
27	A4	Slave address setting pin A4	
37	CTLSCT	Serial bus communication setting pin When set to low: The 3-wire serial bus signals are set as the input signals. When set to high: The I ² C serial bus signals are set as the input signals.	

Continued on next page.

LV5236V

Continued from preceding page.

Pin No.	Pin Name	Pin function	Equivalent Circuit
38	SGND	GND pin	
39	TEST	Test pin This pin must always be connected to GND.	
40	RESET	Reset signal input pin Reset status when set to low.	
41	RT1	Reference current setting resistor connection pin. By connecting the external resistor between this pin and GND, the reference current is generated. The pin voltage is approximately 0.98V. By changing the current level, it is possible to change the oscillator frequency and LED driver current value (in the constant-current mode).	
42	CT	Oscillator frequency setting capacitor connection pin/oscillator input pin. By changing the value of capacitance, it is possible to change the oscillator frequency. The capacitor must be connected to this pin of the master-side IC. The CT pin of the slave-side IC must be connected as the oscillator input pin.	
43	OUTSCT	LED driver output type setting pin When set to low: Constant-current output is set for the LED driver. When set to middle: Open drain output is set for the LED driver. When set to high: Constant-current output is set for the LED driver. However, open drain output is set for the only LED6 driver.	
44	OSC_OUT	Oscillator output pin When a multiple number of driver ICs are connected for use, the oscillators can be connected in synchronization by connecting the OSC_OUT output to the CT pin of the ICs to be connected.	

Continued on next page.

LV5236V

Continued from preceding page.

Pin No.	Pin Name	Pin function	Equivalent Circuit
5 6 7 8 10 12 13 14 15 16 17 19 21 22 28 29 30 31 33 35 36	LEDR1 LEDR2 LEDR3 LEDR4 LEDR5 LEDR7 LEDR8 LEDG1 LEDG2 LEDG3 LEDG4 LEDG5 LEDG7 LEDG8 LEDB1 LEDB2 LEDB3 LEDB4 LEDB5 LEDB7 LEDB8	LEDR1 output pin LEDR2 output pin LEDR3 output pin LEDR4 output pin LEDR5 output pin LEDR7 output pin LEDR8 output pin LEDG1 output pin LEDG2 output pin LEDG3 output pin LEDG4 output pin LEDG5 output pin LEDG7 output pin LEDG8 output pin LEDB1 output pin LEDB2 output pin LEDB3 output pin LEDB4 output pin LEDB5 output pin LEDB7 output pin LEDB8 output pin If these pins are not going to be used, they must always be connected to GND.	
11 20 34	LEDR6 LEDG6 LEDB6	LEDR6 output pin LEDG6 output pin LEDB6 output pin	
9 18 32	PGND1 PGND2 PGND3	GND pin dedicate for LEDR GND pin dedicate for LEDG GND pin dedicate for LEDB	

Serial Bus Communication Specifications

1) 3-wire serial bus transfer timing conditions

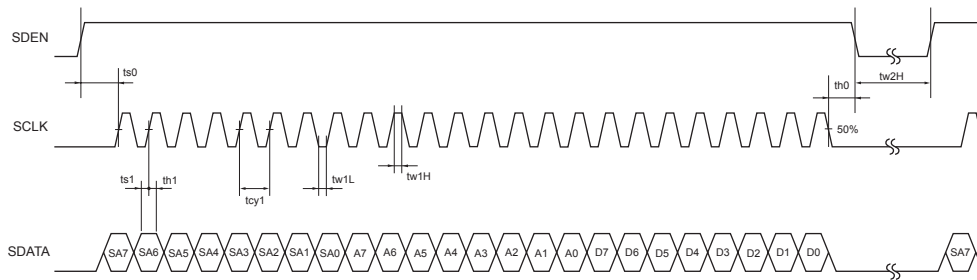

Parameter	Symbol	Conditions	Min.	Typ.	Max.	Unit
Cycle time	tcy1	SCLK clock period	200	-	-	ns
Data setup time	ts0	SDEN setup time relative to the rise of SCLK	90	-	-	ns
	ts1	SDATA setup time relative to the rise of SCLK	60	-	-	ns
Data hold time	th0	SDEN hold time relative to the fall of SCLK	200	-	-	ns
	th1	SDATA hold time relative to the fall of SCLK	60	-	-	ns
Pulse width	tw1L	Low period pulse width of SCLK	90	-	-	ns
	tw1H	High period pulse width of SCLK	90	-	-	ns
	tw2L	Low period pulse width of SDEN	1	-	-	μs

Data length: 24 bits

Clock frequency: 5 MHz or less

When 24 SCLK clock signals have been input during the high period of SDEN, the SDATA is taken in at the rising edge of SCLK.

Note: If the number of SCLK clock signals during the high period of SDEN is 23 or less, SDATA is not taken in. If it is 25 or more, the register address is automatically incremented every time 1 byte is taken in.

The slave address is assigned by the first byte, and the register address on the serial map is specified by the next byte. The third byte transfers the data to the address specified by the register address that was written by the second byte and if the data subsequently continues even after this, the register address is automatically incremented for the fourth and subsequent bytes. As a result, it is possible to send the data continuously from the specified addresses. Data of less than one byte is ignored. However, when the address reaches 2ch, the next byte to be transferred becomes 00h.

Example of a write operation:

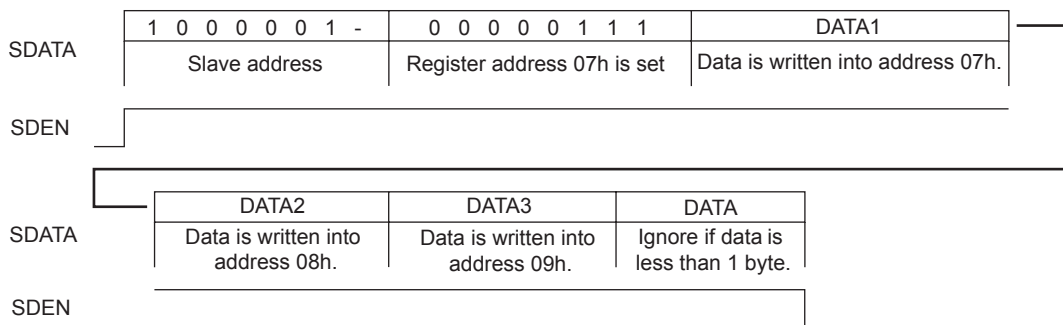

2) I²C serial transfer timing conditions

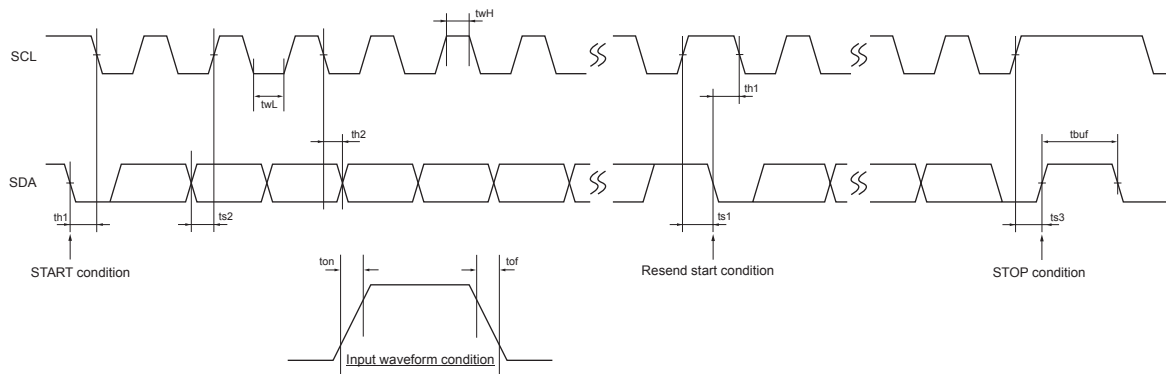

Standard mode

Parameter	Symbol	Conditions	Min.	Typ.	Max.	Unit
SCL clock frequency	fsc1	SCL clock frequency	0	-	100	kHz
Data setup time	ts1	SCL setup time relative to the fall of SDA	4.7	-	-	μs
	ts2	SDA setup time relative to the rise of SCL	250	-	-	ns
	ts3	SCL setup time relative to the rise of SDA	4.0	-	-	μs
Data hold time	th1	SCL hold time relative to the fall of SDA	4.0	-	-	μs
	th2	SDA hold time relative to the fall of SCL	0	-	-	μs
Pulse width	twL	SCL pulse width for the L period	4.7	-	-	μs
	twH	SCL pulse width for the H period	4.0	-	-	μs
Input waveform conditions	ton	SCL and SDA (input) rise time	-	-	1000	ns
	tof	SCL and SDA (input) fall time	-	-	300	ns
Bus free time	tbuf	Time between STOP condition and START condition	4.7	-	-	μs

High-speed mode

Parameter	Symbol	Conditions	Min.	Typ.	Max.	Unit
SCL clock frequency	fsc1	SCL clock frequency	0	-	400	kHz
Data setup time	ts1	SCL setup time relative to the fall of SDA	0.6	-	-	μs
	ts2	SDA setup time relative to the rise of SCL	100	-	-	ns
	ts3	SCL setup time relative to the rise of SDA	0.6	-	-	μs
Data hold time	th1	SCL hold time relative to the fall of SDA	0.6	-	-	μs
	th2	SDA hold time relative to the fall of SCL	0	-	-	μs
Pulse width	twL	SCL pulse width for the L period	1.3	-	-	μs
	twH	SCL pulse width for the H period	0.6	-	-	μs
Input waveform conditions	ton	SCL and SDA (input) rise time	-	-	300	ns
	tof	SCL and SDA (input) fall time	-	-	300	ns
Bus free time	tbuf	Time between STOP and START conditions	1.3	-	-	μs

I²C bus transfer method

Start and stop conditions

During data transfer operation using the I²C bus, SDA must basically be kept in constant state while SCL is “H” as shown below.

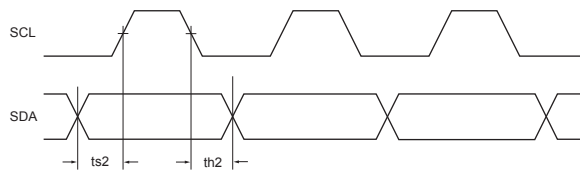

When data is not being transferred, both SCL and SDA are set in the “H” state.

When SCL=SDA is “H,” the start condition is established when SDA is changed from “H” to “L,” and access is started.

When SCL is “H,” the stop condition is established when SDA is changed from “L” to “H,” and access is ended.

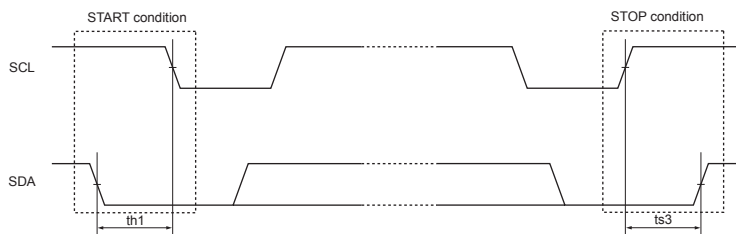

Data transfer and acknowledgement response

After the start condition has been established, the data is transferred one byte (8 bits) at a time.

Any number of bytes of data can be transferred continuously.

Each time the 8-bit data is transferred, the ACK signal is sent from the receive side to the send side. The ACK signal is issued when SDA on the send side is released and SDA on the receive side is set to “L” immediately after fall of the clock pulse at the SCL eighth bit of data transfer to “L.”

When the next 1-byte transfer is left in the receive state after sending the ACK signal from the receive side, the receive side releases SDA at the fall of the SCL ninth clock.

In the I²C bus, there is no CE signal. In its place, a 7-bit slave address is assigned to each device, and the first byte of transfer is assigned to the command (R/W) representing the 7-bit address and subsequent transfer direction. Note that only write is valid in this IC. The 7-bit address is transferred sequentially starting with MSB, and the eighth bit is set to “L” which indicates a write.



LV5236V

Slave address condition

	SLAVE ADDRESS							
	SA7	SA6	SA5	SA4	SA3	SA2	SA1	SA0
register name	-	-	A4	A3	A2	A1	A0	-
default	1	0	0	0	0	0	0	-

Terminal PIN				
A4	A3	A2	A1	A0
L	L	L	L	L
L	L	L	L	H
L	L	L	H	L
L	L	L	H	H
L	L	H	L	L
L	L	H	L	H
L	L	H	H	L
L	L	H	H	H
L	H	L	L	L
L	H	L	L	H
L	H	L	H	L
L	H	L	H	H
L	H	H	L	L
L	H	H	L	H
L	H	H	H	L
L	H	H	H	H
H	L	L	L	L
H	L	L	L	H
H	L	L	H	L
H	L	L	H	H
H	L	H	L	L
H	L	H	L	H
H	L	H	H	L
H	L	H	H	H
H	H	L	L	L
H	H	L	L	H
H	H	L	H	L
H	H	L	H	H
H	H	H	L	L
H	H	H	L	H
H	H	H	H	L
H	H	H	H	H

:LV5236

SA7	SA6	SA5	SA4	SA3	SA2	SA1	SA0
1	0	0	0	0	0	0	-
1	0	0	0	0	0	1	-
1	0	0	0	0	1	0	-
1	0	0	0	0	1	1	-
1	0	0	0	1	0	0	-
1	0	0	0	1	0	1	-
1	0	0	0	1	1	0	-
1	0	0	0	1	1	1	-
1	0	0	1	0	0	0	-
1	0	0	1	0	0	1	-
1	0	0	1	0	1	0	-
1	0	0	1	0	1	1	-
1	0	0	1	1	0	0	-
1	0	0	1	1	0	1	-
1	0	0	1	1	1	0	-
1	0	0	1	1	1	1	-
1	0	1	0	0	0	0	-
1	0	1	0	0	0	1	-
1	0	1	0	0	1	1	-
1	0	1	0	1	0	0	-
1	0	1	0	1	0	1	-
1	0	1	0	1	1	0	-
1	0	1	0	1	1	1	-
1	0	1	1	0	0	0	-
1	0	1	1	0	0	1	-
1	0	1	1	0	1	0	-
1	0	1	1	0	1	1	-
1	0	1	1	1	0	0	-
1	0	1	1	1	0	1	-
1	0	1	1	1	1	0	-
1	0	1	1	1	1	1	-

LV5236V

Serial each mode setting

	ADDRESS : 00h							
	D7	D6	D5	D4	D3	D2	D1	D0
register name	-	PWM[2]	PWM[1]	PWM[0]	-	-	MAS	-
default	0	0	0	0	0	0	0	0

D6	D5	D4	time(ms)
0	0	0	0.5
0	0	1	1.0
0	1	0	2.0
0	1	1	4.0
1	0	0	8.0
-	-	-	-
-	-	-	-
-	-	-	-
-	-	-	-

PWM cycle setting
*Default

D1	MAS
0	Master
1	Slave

Master/Slave setting
*Default

	ADDRESS : 01h							
	D7	D6	D5	D4	D3	D2	D1	D0
register name	-	FOUT[2]	FOUT[1]	FOUT[0]	-	FIN[2]	FIN[1]	FIN[0]
default	0	0	0	0	0	0	0	0

D6	D5	D4	time(ms)
0	0	0	No slope
0	0	1	0.5
0	1	0	1.0
0	1	1	2.0
1	0	0	4.0
1	0	1	8.0
1	1	0	16.0
1	1	1	32.0

Fout slope setting
*Default

Speed of fade a step

(It takes 256 above-mentioned, set value × seconds until the fade is completed.)

D2	D1	D0	time(ms)
0	0	0	No slope
0	0	1	0.5
0	1	0	1.0
0	1	1	2.0
1	0	0	4.0
1	0	1	8.0
1	1	0	16.0
1	1	1	32.0

Fin slope setting
*Default

Speed of fade a step

(It takes 256 above-mentioned, set value × seconds until the fade is completed.)

LV5236V

	ADDRESS : 02h							
	D7	D6	D5	D4	D3	D2	D1	D0
register name	-	-	-	RLED[4]	RLED[3]	RLED[2]	RLED[1]	RLED[0]
default	0	0	0	0	0	0	0	0

D4	D3	D2	D1	D0	Current value (mA)
0	0	0	0	0	0.96
0	0	0	0	1	1.92
0	0	0	1	0	2.88
0	0	0	1	1	3.84
0	0	1	0	0	4.80
0	0	1	0	1	5.76
0	0	1	1	0	6.72
0	0	1	1	1	7.68
0	1	0	0	0	8.64
0	1	0	0	1	9.60
0	1	0	1	0	10.56
0	1	0	1	1	11.52
0	1	1	0	0	12.48
0	1	1	0	1	13.44
0	1	1	1	0	14.40
0	1	1	1	1	15.36
1	0	0	0	0	16.32
1	0	0	0	1	17.28
1	0	0	1	0	18.24
1	0	0	1	1	19.20
1	0	1	0	0	20.16
1	0	1	0	1	21.12
1	0	1	1	0	22.08
1	0	1	1	1	23.04
1	1	0	0	0	24.00
1	1	0	0	1	24.96
1	1	0	1	0	25.92
1	1	0	1	1	26.88
1	1	1	0	0	27.84
1	1	1	0	1	28.80
1	1	1	1	0	29.76
1	1	1	1	1	30.72

RLED current value setting
* Default

LV5236V

	ADDRESS : 03h							
	D7	D6	D5	D4	D3	D2	D1	D0
register name	-	-	-	GLED[4]	GLED[3]	GLED[2]	GLED[1]	GLED[0]
default	0	0	0	0	0	0	0	0

D4	D3	D2	D1	D0	Current value (mA)
0	0	0	0	0	0.96
0	0	0	0	1	1.92
0	0	0	1	0	2.88
0	0	0	1	1	3.84
0	0	1	0	0	4.80
0	0	1	0	1	5.76
0	0	1	1	0	6.72
0	0	1	1	1	7.68
0	1	0	0	0	8.64
0	1	0	0	1	9.60
0	1	0	1	0	10.56
0	1	0	1	1	11.52
0	1	1	0	0	12.48
0	1	1	0	1	13.44
0	1	1	1	0	14.40
0	1	1	1	1	15.36
1	0	0	0	0	16.32
1	0	0	0	1	17.28
1	0	0	1	0	18.24
1	0	0	1	1	19.20
1	0	1	0	0	20.16
1	0	1	0	1	21.12
1	0	1	1	0	22.08
1	0	1	1	1	23.04
1	1	0	0	0	24.00
1	1	0	0	1	24.96
1	1	0	1	0	25.92
1	1	0	1	1	26.88
1	1	1	0	0	27.84
1	1	1	0	1	28.80
1	1	1	1	0	29.76
1	1	1	1	1	30.72

GLED current value setting
* Default

LV5236V

	ADDRESS : 04h							
	D7	D6	D5	D4	D3	D2	D1	D0
register name	-	-	-	BLED[4]	BLED[3]	BLED[2]	BLED[1]	BLED[0]
default	0	0	0	0	0	0	0	0

D4	D3	D2	D1	D0	Current value (mA)
0	0	0	0	0	0.96
0	0	0	0	1	1.92
0	0	0	1	0	2.88
0	0	0	1	1	3.84
0	0	1	0	0	4.80
0	0	1	0	1	5.76
0	0	1	1	0	6.72
0	0	1	1	1	7.68
0	1	0	0	0	8.64
0	1	0	0	1	9.60
0	1	0	1	0	10.56
0	1	0	1	1	11.52
0	1	1	0	0	12.48
0	1	1	0	1	13.44
0	1	1	1	0	14.40
0	1	1	1	1	15.36
1	0	0	0	0	16.32
1	0	0	0	1	17.28
1	0	0	1	0	18.24
1	0	0	1	1	19.20
1	0	1	0	0	20.16
1	0	1	0	1	21.12
1	0	1	1	0	22.08
1	0	1	1	1	23.04
1	1	0	0	0	24.00
1	1	0	0	1	24.96
1	1	0	1	0	25.92
1	1	0	1	1	26.88
1	1	1	0	0	27.84
1	1	1	0	1	28.80
1	1	1	1	0	29.76
1	1	1	1	1	30.72

BLED current value setting
* Default

LV5236V

	ADDRESS : 05h							
	D7	D6	D5	D4	D3	D2	D1	D0
register name	-	B2ON	G2ON	R2ON	-	B1ON	G1ON	R1ON
default	0	0	0	0	0	0	0	0

D6	B2ON	LEDB2 ON/OFF setting
0	OFF	* Default
1	ON	

D5	G2ON	LEDG2 ON/OFF setting
0	OFF	* Default
1	ON	

D4	R2ON	LEDR2 ON/OFF setting
0	OFF	* Default
1	ON	

D2	B1ON	LEDB1 ON/OFF setting
0	OFF	* Default
1	ON	

D1	G1ON	LEDG1ON/OFF setting
0	OFF	* Default
1	ON	

D0	R1ON	LEDR1 ON/OFF setting
0	OFF	* Default
1	ON	

	ADDRESS : 06h							
	D7	D6	D5	D4	D3	D2	D1	D0
register name	-	B4ON	G4ON	R4ON	-	B3ON	G3ON	R3ON
default	0	0	0	0	0	0	0	0

D6	B4ON	LEDB4 ON/OFF setting
0	OFF	* Default
1	ON	

D5	G4ON	LEDG4 ON/OFF setting
0	OFF	* Default
1	ON	

D4	R4ON	LEDR4 ON/OFF setting
0	OFF	* Default
1	ON	

D2	B3ON	LEDB3 ON/OFF setting
0	OFF	* Default
1	ON	

D1	G3ON	LEDG3 ON/OFF setting
0	OFF	* Default
1	ON	

D0	R3ON	LEDR3 ON/OFF setting
0	OFF	* Default
1	ON	

LV5236V

	ADDRESS : 07h							
	D7	D6	D5	D4	D3	D2	D1	D0
register name	-	B6ON	G6ON	R6ON	-	B5ON	G5ON	R5ON
default	0	0	0	0	0	0	0	0

D6	B6ON	LEDB6 ON/OFF setting
0	OFF	* Default
1	ON	

D5	G6ON	LEDG6 ON/OFF setting
0	OFF	* Default
1	ON	

D4	R6ON	LEDR6 ON/OFF setting
0	OFF	* Default
1	ON	

D2	B5ON	LEDB5 ON/OFF setting
0	OFF	* Default
1	ON	

D1	G5ON	LEDG5 ON/OFF setting
0	OFF	* Default
1	ON	

D0	R5ON	LEDR5 ON/OFF setting
0	OFF	* Default
1	ON	

	ADDRESS : 08h							
	D7	D6	D5	D4	D3	D2	D1	D0
register name	-	B8ON	G8ON	R8ON	-	B7ON	G7ON	R7ON
default	0	0	0	0	0	0	0	0

D6	B8ON	LEDB8 ON/OFF setting
0	OFF	* Default
1	ON	

D5	G8ON	LEDG8 ON/OFF setting
0	OFF	* Default
1	ON	

D4	R8ON	LEDR8 ON/OFF setting
0	OFF	* Default
1	ON	

D2	B7ON	LEDB7 ON/OFF setting
0	OFF	* Default
1	ON	

D1	G7ON	LEDG7 ON/OFF setting
0	OFF	* Default
1	ON	

D0	R7ON	LEDR7 ON/OFF setting
0	OFF	* Default
1	ON	

LV5236V

	ADDRESS : 09h							
	D7	D6	D5	D4	D3	D2	D1	D0
register name	R7PON[1]	R7PON[0]	R5PON[1]	R5PON[0]	R3PON[1]	R3PN[0]	R1PON[1]	R1PON[0]
default	0	0	0	0	0	0	0	0

D7	D6	R5PON
0	0	PMW output priority
0	1	Fade output priority
1	0	Compulsion ON/OFF output priority
-	-	-

LEDR7 output setting
* Default

D5	D4	R5PON
0	0	PMW output priority
0	1	Fade output priority
1	0	Compulsion ON/OFF output priority
-	-	-

LEDR5 output setting
* Default

D3	D2	R3PON
0	0	PMW output priority
0	1	Fade output priority
1	0	Compulsion ON/OFF output priority
-	-	-

LEDR3 output setting
* Default

D1	D0	R1PON
0	0	PMW output priority
0	1	Fade output priority
1	0	Compulsion ON/OFF output priority
-	-	-

LEDR1 output setting
* Default

	ADDRESS : 0ah							
	D7	D6	D5	D4	D3	D2	D1	D0
register name	R8PON[1]	R8PON[0]	R6PON[1]	R6PON[0]	R4PON[1]	R4PON[0]	R2PON[1]	R2PON[0]
default	0	0	0	0	0	0	0	0

D7	D6	R8PON
0	0	PMW output priority
0	1	Fade output priority
1	0	Compulsion ON/OFF output priority
-	-	-

LEDR8 output setting
* Default

D5	D4	R6PON
0	0	PMW output priority
0	1	Fade output priority
1	0	Compulsion ON/OFF output priority
-	-	-

LEDR6 output setting
* Default

D3	D2	R4PON
0	0	PMW output priority
0	1	Fade output priority
1	0	Compulsion ON/OFF output priority
-	-	-

LEDR4 output setting
* Default

D1	D0	R2PON
0	0	PMW output priority
0	1	Fade output priority
1	0	Compulsion ON/OFF output priority
-	-	-

LEDR2 output setting
* Default

LV5236V

	ADDRESS : 0bh							
	D7	D6	D5	D4	D3	D2	D1	D0
register name	G7PON[1]	G7PON[0]	G5PON[1]	G5PON[0]	G3PON[1]	G3PON[0]	G1PON[1]	G1PON[0]
default	0	0	0	0	0	0	0	0

D7	D6	G7PON
0	0	PMW output priority
0	1	Fade output priority
1	0	Compulsion ON/OFF output priority
-	-	-

LEDG7 output setting
* Default

D5	D4	G5PON
0	0	PMW output priority
0	1	Fade output priority
1	0	Compulsion ON/OFF output priority
-	-	-

LEDG5 output setting
* Default

D3	D2	G3PON
0	0	PMW output priority
0	1	Fade output priority
1	0	Compulsion ON/OFF output priority
-	-	-

LEDG3 output setting
* Default

D1	D0	G1PON
0	0	PMW output priority
0	1	Fade output priority
1	0	Compulsion ON/OFF output priority
-	-	-

LEDG1 output setting
* Default

	ADDRESS : 0ch							
	D7	D6	D5	D4	D3	D2	D1	D0
register name	G8PON[1]	G8PON[0]	G6PON[1]	G6PON[0]	G4PON[1]	G4PON[0]	G2PON[1]	G2PON[0]
default	0	0	0	0	0	0	0	0

D7	D6	G8PON
0	0	PMW output priority
0	1	Fade output priority
1	0	Compulsion ON/OFF output priority
-	-	-

LEDG8 output setting
* Default

D5	D4	G6PON
0	0	PMW output priority
0	1	Fade output priority
1	0	Compulsion ON/OFF output priority
-	-	-

LEDG6 output setting
* Default

D3	D2	G4PON
0	0	PMW output priority
0	1	Fade output priority
1	0	Compulsion ON/OFF output priority
-	-	-

LEDG4 output setting
* Default

D1	D0	G2PON
0	0	PMW output priority
0	1	Fade output priority
1	0	Compulsion ON/OFF output priority
-	-	-

LEDG2 output setting
* Default

LV5236V

	ADDRESS : 0dh							
	D7	D6	D5	D4	D3	D2	D1	D0
register name	B7PON[1]	B7PON[0]	B5PON[1]	B5PON[0]	B3PON[1]	B3PON[0]	B1PON[1]	B1PON[0]
default	0	0	0	0	0	0	0	0

D7	D6	B7PON
0	0	PMW output priority
0	1	Fade output priority
1	0	Compulsion ON/OFF output priority
-	-	-

LEDB7 output setting
* Default

D5	D4	B5PON
0	0	PMW output priority
0	1	Fade output priority
1	0	Compulsion ON/OFF output priority
-	-	-

LEDB5 output setting
* Default

D3	D2	B3PON
0	0	PMW output priority
0	1	Fade output priority
1	0	Compulsion ON/OFF output priority
-	-	-

LEDB3 output setting
* Default

D1	D0	B1PON
0	0	PMW output priority
0	1	Fade output priority
1	0	Compulsion ON/OFF output priority
-	-	-

LEDB1 output setting
* Default

	ADDRESS : 0eh							
	D7	D6	D5	D4	D3	D2	D1	D0
register name	B8PON[1]	B8PON[0]	B6PON[1]	B6PON[0]	B4PON[1]	B4PON[0]	B2PON[1]	B2PON[0]
default	0	0	0	0	0	0	0	0

D7	D6	B8PON
0	0	PMW output priority
0	1	Fade output priority
1	0	Compulsion ON/OFF output priority
-	-	-

LEDB8 output setting
* Default

D5	D4	B6PON
0	0	PMW output priority
0	1	Fade output priority
1	0	Compulsion ON/OFF output priority
-	-	-

LEDB6 output setting
* Default

D3	D2	B4PON
0	0	PMW output priority
0	1	Fade output priority
1	0	Compulsion ON/OFF output priority
-	-	-

LEDB4 output setting
* Default

D1	D0	B2PON
0	0	PMW output priority
0	1	Fade output priority
1	0	Compulsion ON/OFF output priority
-	-	-

LEDB2 output setting
* Default

LV5236V

	ADDRESS : 0fh							
	D7	D6	D5	D4	D3	D2	D1	D0
register name	R8FD	R7FD	R6FD	R5FD	R4FD	R3FD	R2FD	R1FD
default	0	0	0	0	0	0	0	0

D7	R8FD
0	Fade invalidity
1	Fade effective

LEDR8 fade function ON/OFF setting
* Default

D6	R7FD
0	Fade invalidity
1	Fade effective

LEDR7 fade function ON/OFF setting
* Default

D5	R6FD
0	Fade invalidity
1	Fade effective

LEDR6 fade function ON/OFF setting
* Default

D4	R5FD
0	Fade invalidity
1	Fade effective

LEDR5 fade function ON/OFF setting
* Default

D3	R4FD
0	Fade invalidity
1	Fade effective

LEDR4 fade function ON/OFF setting
* Default

D2	R3FD
0	Fade invalidity
1	Fade effective

LEDR3 fade function ON/OFF setting
* Default

D1	R2FD
0	Fade invalidity
1	Fade effective

LEDR2 fade function ON/OFF setting
* Default

D0	R1FD
0	Fade invalidity
1	Fade effective

LEDR1 fade function ON/OFF setting
* Default

LV5236V

	ADDRESS : 10h							
	D7	D6	D5	D4	D3	D2	D1	D0
register name	G8FD	G7FD	G6FD	G5FD	G4FD	G3FD	G2FD	G1FD
default	0	0	0	0	0	0	0	0

D7	G8FD	LEDG8 fade function ON/OFF setting
0	Fade invalidity	* Default
1	Fade effective	

D6	G7FD	LEDG7 fade function ON/OFF setting
0	Fade invalidity	* Default
1	Fade effective	

D5	G6FD	LEDG6 fade function ON/OFF setting
0	Fade invalidity	* Default
1	Fade effective	

D4	G5FD	LEDG5 fade function ON/OFF setting
0	Fade invalidity	* Default
1	Fade effective	

D3	G4FD	LEDG4 fade function ON/OFF setting
0	Fade invalidity	* Default
1	Fade effective	

D2	G3FD	LEDG3 fade function ON/OFF setting
0	Fade invalidity	* Default
1	Fade effective	

D1	G2FD	LEDG2 fade function ON/OFF setting
0	Fade invalidity	* Default
1	Fade effective	

D0	G1FD	LEDG1 fade function ON/OFF setting
0	Fade invalidity	* Default
1	Fade effective	

LV5236V

	ADDRESS : 11h							
	D7	D6	D5	D4	D3	D2	D1	D0
register name	B8FD	B7FD	B6FD	B5FD	B4FD	B3FD	B2FD	B1FD
default	0	0	0	0	0	0	0	0

D7	B8FD	LEDB8 fade function ON/OFF setting
0	Fade invalidity	* Default
1	Fade effective	

D6	B7FD	LEDB7 fade function ON/OFF setting
0	Fade invalidity	* Default
1	Fade effective	

D5	B6FD	LEDB6 fade function ON/OFF setting
0	Fade invalidity	* Default
1	Fade effective	

D4	B5FD	LEDB5 fade function ON/OFF setting
0	Fade invalidity	* Default
1	Fade effective	

D3	B4FD	LEDB4 fade function ON/OFF setting
0	Fade invalidity	* Default
1	Fade effective	

D2	B3FD	LEDB3 fade function ON/OFF setting
0	Fade invalidity	* Default
1	Fade effective	

D1	B2FD	LEDB2 fade function ON/OFF setting
0	Fade invalidity	* Default
1	Fade effective	

D0	B1FD	LEDB1 fade function ON/OFF setting
0	Fade invalidity	* Default
1	Fade effective	

LV5236V

	ADDRESS : 12h							
	D7	D6	D5	D4	D3	D2	D1	D0
register name	R8CM	R7CM	R6CM	R5CM	R4CM	R3CM	R2CM	R1CM
default	0	0	0	0	0	0	0	0

D7	R8CM	LEDR8 compulsion ON/OFF setting
0	Compulsion OFF	* Default
1	Compulsion ON	

D6	R7CM	LEDR7 compulsion ON/OFF setting
0	Compulsion OFF	* Default
1	Compulsion ON	

D5	R6CM	LEDR6 compulsion ON/OFF setting
0	Compulsion OFF	* Default
1	Compulsion ON	

D4	R5CM	LEDR5 compulsion ON/OFF setting
0	Compulsion OFF	* Default
1	Compulsion ON	

D3	R4CM	LEDR4 compulsion ON/OFF setting
0	Compulsion OFF	* Default
1	Compulsion ON	

D2	R3CM	LEDR3 fade function ON/OFF setting
0	Compulsion OFF	* Default
1	Compulsion ON	

D1	R2CM	LEDR2 fade function ON/OFF setting
0	Compulsion OFF	* Default
1	Compulsion ON	

D0	R1CM	LEDR1 fade function ON/OFF setting
0	Compulsion OFF	* Default
1	Compulsion ON	

LV5236V

	ADDRESS : 13h							
	D7	D6	D5	D4	D3	D2	D1	D0
register name	G8CM	G7CM	G6CM	G5CM	G4CM	G3CM	G2CM	G1CM
default	0	0	0	0	0	0	0	0

D7	G8CM	LEDG8 compulsion ON/OFF setting
0	Compulsion OFF	* Default
1	Compulsion ON	

D6	G7CM	LEDG7 compulsion ON/OFF setting
0	Compulsion OFF	* Default
1	Compulsion ON	

D5	G6CM	LEDG6 compulsion ON/OFF setting
0	Compulsion OFF	* Default
1	Compulsion ON	

D4	G5CM	LEDG5 compulsion ON/OFF setting
0	Compulsion OFF	* Default
1	Compulsion ON	

D3	G4CM	LEDG4 compulsion ON/OFF setting
0	Compulsion OFF	* Default
1	Compulsion ON	

D2	G3CM	LEDG3 fade function ON/OFF setting
0	Compulsion OFF	* Default
1	Compulsion ON	

D1	G2CM	LEDG2 fade function ON/OFF setting
0	Compulsion OFF	* Default
1	Compulsion ON	

D0	G1CM	LEDG1 fade function ON/OFF setting
0	Compulsion OFF	* Default
1	Compulsion ON	

LV5236V

	ADDRESS : 14h							
	D7	D6	D5	D4	D3	D2	D1	D0
register name	B8CM	B7CM	B6CM	B5CM	B4CM	B3CM	B2CM	B1CM
default	0	0	0	0	0	0	0	0

D7	B8CM	LEDB8 compulsion ON/OFF setting
0	Compulsion OFF	* Default
1	Compulsion ON	

D6	B7CM	LEDB7 compulsion ON/OFF setting
0	Compulsion OFF	* Default
1	Compulsion ON	

D5	B6CM	LEDB6 compulsion ON/OFF setting
0	Compulsion OFF	* Default
1	Compulsion ON	

D4	B5CM	LEDB5 compulsion ON/OFF setting
0	Compulsion OFF	* Default
1	Compulsion ON	

D3	B4CM	LEDB4 compulsion ON/OFF setting
0	Compulsion OFF	* Default
1	Compulsion ON	

D2	B3CM	LEDB3 fade function ON/OFF setting
0	Compulsion OFF	* Default
1	Compulsion ON	

D1	B2CM	LEDB2 fade function ON/OFF setting
0	Compulsion OFF	* Default
1	Compulsion ON	

D0	B1CM	LEDB1 fade function ON/OFF setting
0	Compulsion OFF	* Default
1	Compulsion ON	

LV5236V

	ADDRESS : 15h							
	D7	D6	D5	D4	D3	D2	D1	D0
register name	R1PWM[7]	R1PWM[6]	R1PWM[5]	R1PWM[4]	R1PWM[3]	R1PWM[2]	R1PWM[1]	R1PWM[0]
default	0	0	0	0	0	0	0	0

LEDR1 PWM Duty setting (Default ALL0)

D	Duty (%)
00h	0.0
ffh	99.6

$$\text{Duty (\%)} = \frac{\text{R1PWM}[7:0]}{256}$$

	ADDRESS : 16h							
	D7	D6	D5	D4	D3	D2	D1	D0
register name	G1PWM[7]	G1PWM[6]	G1PWM[5]	G1PWM[4]	G1PWM[3]	G1PWM[2]	G1PWM[1]	G1PWM[0]
default	0	0	0	0	0	0	0	0

LEDG1 PWM Duty setting (Default ALL0)

D	Duty (%)
00h	0.0
ffh	99.6

$$\text{Duty (\%)} = \frac{\text{G1PWM}[7:0]}{256}$$

	ADDRESS : 17h							
	D7	D6	D5	D4	D3	D2	D1	D0
register name	B1PWM[7]	B1PWM[6]	B1PWM[5]	B1PWM[4]	B1PWM[3]	B1PWM[2]	B1PWM[1]	B1PWM[0]
default	0	0	0	0	0	0	0	0

LEDB1 PWM Duty setting (Default ALL0)

D	Duty (%)
00h	0.0
ffh	99.6

$$\text{Duty (\%)} = \frac{\text{B1PWM}[7:0]}{256}$$

	ADDRESS : 18h							
	D7	D6	D5	D4	D3	D2	D1	D0
register name	R2PWM[7]	R2PWM[6]	R2PWM[5]	R2PWM[4]	R2PWM[3]	R2PWM[2]	R2PWM[1]	R2PWM[0]
default	0	0	0	0	0	0	0	0

LEDR2 PWM Duty setting (Default ALL0)

D	Duty (%)
00h	0.0
ffh	99.6

$$\text{Duty (\%)} = \frac{\text{R2PWM}[7:0]}{256}$$

	ADDRESS : 19h							
	D7	D6	D5	D4	D3	D2	D1	D0
register name	G2PWM[7]	G2PWM[6]	G2PWM[5]	G2PWM[4]	G2PWM[3]	G2PWM[2]	G2PWM[1]	G2PWM[0]
default	0	0	0	0	0	0	0	0

LEDG2 PWM Duty setting (Default ALL0)

D	Duty (%)
00h	0.0
ffh	99.6

$$\text{Duty (\%)} = \frac{\text{G2PWM}[7:0]}{256}$$

	ADDRESS : 1ah							
	D7	D6	D5	D4	D3	D2	D1	D0
register name	B2PWM[7]	B2PWM[6]	B2PWM[5]	B2PWM[4]	B2PWM[3]	B2PWM[2]	B2PWM[1]	B2PWM[0]
default	0	0	0	0	0	0	0	0

LEDB2 PWM Duty setting (Default ALL0)

D	Duty (%)
00h	0.0
ffh	99.6

$$\text{Duty (\%)} = \frac{\text{B2PWM}[7:0]}{256}$$

LV5236V

	ADDRESS : 1bh							
	D7	D6	D5	D4	D3	D2	D1	D0
register name	R3PWM[7]	R3PWM[6]	R3PWM[5]	R3PWM[4]	R3PWM[3]	R3PWM[2]	R3PWM[1]	R3PWM[0]
default	0	0	0	0	0	0	0	0

LEDR3 PWM Duty setting (Default ALL0)

D	Duty (%)
00h	0.0
ffh	99.6

$$\text{Duty (\%)} = \frac{\text{R3PWM}[7:0]}{256}$$

	ADDRESS : 1ch							
	D7	D6	D5	D4	D3	D2	D1	D0
register name	G3PWM[7]	G3PWM[6]	G3PWM[5]	G3PWM[4]	G3PWM[3]	G3PWM[2]	G3PWM[1]	G3PWM[0]
default	0	0	0	0	0	0	0	0

LEDG3 PWM Duty setting (Default ALL0)

D	Duty (%)
00h	0.0
ffh	99.6

$$\text{Duty (\%)} = \frac{\text{G3PWM}[7:0]}{256}$$

	ADDRESS : 1dh							
	D7	D6	D5	D4	D3	D2	D1	D0
register name	B3PWM[7]	B3PWM[6]	B3PWM[5]	B3PWM[4]	B3PWM[3]	B3PWM[2]	B3PWM[1]	B3PWM[0]
default	0	0	0	0	0	0	0	0

LEDB3 PWM Duty setting (Default ALL0)

D	Duty (%)
00h	0.0
ffh	99.6

$$\text{Duty (\%)} = \frac{\text{B3PWM}[7:0]}{256}$$

	ADDRESS : 1eh							
	D7	D6	D5	D4	D3	D2	D1	D0
register name	R4PWM[7]	R4PWM[6]	R4PWM[5]	R4PWM[4]	R4PWM[3]	R4PWM[2]	R4PWM[1]	R4PWM[0]
default	0	0	0	0	0	0	0	0

LEDR4 PWM Duty setting (Default ALL0)

D	Duty (%)
00h	0.0
ffh	99.6

$$\text{Duty (\%)} = \frac{\text{R4PWM}[7:0]}{256}$$

	ADDRESS : 1fh							
	D7	D6	D5	D4	D3	D2	D1	D0
register name	G4PWM[7]	G4PWM[6]	G4PWM[5]	G4PWM[4]	G4PWM[3]	G4PWM[2]	G4PWM[1]	G4PWM[0]
default	0	0	0	0	0	0	0	0

LEDG4 PWM Duty setting (Default ALL0)

D	Duty (%)
00h	0.0
ffh	99.6

$$\text{Duty (\%)} = \frac{\text{G4PWM}[7:0]}{256}$$

	ADDRESS : 20h							
	D7	D6	D5	D4	D3	D2	D1	D0
register name	B4PWM[7]	B4PWM[6]	B4PWM[5]	B4PWM[4]	B4PWM[3]	B4PWM[2]	B4PWM[1]	B4PWM[0]
default	0	0	0	0	0	0	0	0

LEDB4 PWM Duty setting (Default ALL0)

D	Duty (%)
00h	0.0
ffh	99.6

$$\text{Duty (\%)} = \frac{\text{B4PWM}[7:0]}{256}$$

LV5236V

	ADDRESS : 21h							
	D7	D6	D5	D4	D3	D2	D1	D0
register name	R5PWM[7]	R5PWM[6]	R5PWM[5]	R5PWM[4]	R5PWM[3]	R5PWM[2]	R5PWM[1]	R5PWM[0]
default	0	0	0	0	0	0	0	0

LEDR5 PWM Duty setting (Default ALL0)

D	Duty (%)
00h	0.0
ffh	99.6

$$\text{Duty (\%)} = \frac{\text{R5PWM}[7:0]}{256}$$

	ADDRESS : 22h							
	D7	D6	D5	D4	D3	D2	D1	D0
register name	G5PWM[7]	G5PWM[6]	G5PWM[5]	G5PWM[4]	G5PWM[3]	G5PWM[2]	G5PWM[1]	G5PWM[0]
default	0	0	0	0	0	0	0	0

LEDG5 PWM Duty setting (Default ALL0)

D	Duty (%)
00h	0.0
ffh	99.6

$$\text{Duty (\%)} = \frac{\text{G5PWM}[7:0]}{256}$$

	ADDRESS : 23h							
	D7	D6	D5	D4	D3	D2	D1	D0
register name	B5PWM[7]	B5PWM[6]	B5PWM[5]	B5PWM[4]	B5PWM[3]	B5PWM[2]	B5PWM[1]	B5PWM[0]
default	0	0	0	0	0	0	0	0

LEDB5 PWM Duty setting (Default ALL0)

D	Duty (%)
00h	0.0
ffh	99.6

$$\text{Duty (\%)} = \frac{\text{B5PWM}[7:0]}{256}$$

	ADDRESS : 24h							
	D7	D6	D5	D4	D3	D2	D1	D0
register name	R6PWM[7]	R6PWM[6]	R6PWM[5]	R6PWM[4]	R6PWM[3]	R6PWM[2]	R6PWM[1]	R6PWM[0]
default	0	0	0	0	0	0	0	0

LEDR6 PWM Duty setting (Default ALL0)

D	Duty (%)
00h	0.0
ffh	99.6

$$\text{Duty (\%)} = \frac{\text{R6PWM}[7:0]}{256}$$

	ADDRESS : 25h							
	D7	D6	D5	D4	D3	D2	D1	D0
register name	G6PWM[7]	G6PWM[6]	G6PWM[5]	G6PWM[4]	G6PWM[3]	G6PWM[2]	G6PWM[1]	G6PWM[0]
default	0	0	0	0	0	0	0	0

LEDG6 PWM Duty setting (Default ALL0)

D	Duty (%)
00h	0.0
ffh	99.6

$$\text{Duty (\%)} = \frac{\text{G6PWM}[7:0]}{256}$$

	ADDRESS : 26h							
	D7	D6	D5	D4	D3	D2	D1	D0
register name	B6PWM[7]	B6PWM[6]	B6PWM[5]	B6PWM[4]	B6PWM[3]	B6PWM[2]	B6PWM[1]	B6PWM[0]
default	0	0	0	0	0	0	0	0

LEDB6 PWM Duty setting (Default ALL0)

D	Duty (%)
00h	0.0
ffh	99.6

$$\text{Duty (\%)} = \frac{\text{B6PWM}[7:0]}{256}$$

LV5236V

	ADDRESS : 27h							
	D7	D6	D5	D4	D3	D2	D1	D0
register name	R7PWM[7]	R7PWM[6]	R7PWM[5]	R7PWM[4]	R7PWM[3]	R7PWM[2]	R7PWM[1]	R7PWM[0]
default	0	0	0	0	0	0	0	0

LEDR7 PWM Duty setting (Default ALL0)

D	Duty (%)
00h	0.0
ffh	99.6

$$\text{Duty (\%)} = \frac{\text{R7PWM}[7:0]}{256}$$

	ADDRESS : 28h							
	D7	D6	D5	D4	D3	D2	D1	D0
register name	G7PWM[7]	G7PWM[6]	G7PWM[5]	G7PWM[4]	G7PWM[3]	G7PWM[2]	G7PWM[1]	G7PWM[0]
default	0	0	0	0	0	0	0	0

LEDG7 PWM Duty setting (Default ALL0)

D	Duty (%)
00h	0.0
ffh	99.6

$$\text{Duty (\%)} = \frac{\text{G7PWM}[7:0]}{256}$$

	ADDRESS : 29h							
	D7	D6	D5	D4	D3	D2	D1	D0
register name	B7PWM[7]	B7PWM[6]	B7PWM[5]	B7PWM[4]	B7PWM[3]	B7PWM[2]	B7PWM[1]	B7PWM[0]
default	0	0	0	0	0	0	0	0

LEDB7 PWM Duty setting (Default ALL0)

D	Duty (%)
00h	0.0
ffh	99.6

$$\text{Duty (\%)} = \frac{\text{B7PWM}[7:0]}{256}$$

	ADDRESS : 2ah							
	D7	D6	D5	D4	D3	D2	D1	D0
register name	R8PWM[7]	R8PWM[6]	R8PWM[5]	R8PWM[4]	R8PWM[3]	R8PWM[2]	R8PWM[1]	R8PWM[0]
default	0	0	0	0	0	0	0	0

LEDR8 PWM Duty setting (Default ALL0)

D	Duty (%)
00h	0.0
ffh	99.6

$$\text{Duty (\%)} = \frac{\text{R8PWM}[7:0]}{256}$$

	ADDRESS : 2bh							
	D7	D6	D5	D4	D3	D2	D1	D0
register name	G8PWM[7]	G8PWM[6]	G8PWM[5]	G8PWM[4]	G8PWM[3]	G8PWM[2]	G8PWM[1]	G8PWM[0]
default	0	0	0	0	0	0	0	0

LEDG8 PWM Duty setting (Default ALL0)

D	Duty (%)
00h	0.0
ffh	99.6

$$\text{Duty (\%)} = \frac{\text{G8PWM}[7:0]}{256}$$

	ADDRESS : 2ch							
	D7	D6	D5	D4	D3	D2	D1	D0
register name	B8PWM[7]	B8PWM[6]	B8PWM[5]	B8PWM[4]	B8PWM[3]	B8PWM[2]	B8PWM[1]	B8PWM[0]
default	0	0	0	0	0	0	0	0

LEDB8 PWM Duty setting (Default ALL0)

D	Duty (%)
00h	0.0
ffh	99.6

$$\text{Duty (\%)} = \frac{\text{B8PWM}[7:0]}{256}$$

LV5236V

LV5236V serial map

• Table upper row: Register name Table the lower: Default value

	A7	A6	A5	A4	A3	A2	A1	A0	D7	D6	D5	D4	D3	D2	D1	D0
00h	0	0	0	0	0	0	0	0	×	PWM[2:0]			×	×	MAS	×
									0	0	0	0	0	0	0	
01h	0	0	0	0	0	0	0	1	×	FOUT[2:0]			×	FIN[2:0]		
									0	0	0	0	0	0	0	
02h	0	0	0	0	0	0	1	0	×	×	×	RLED[4:0]				
									0	0	0	0	0	0	0	
03h	0	0	0	0	0	0	1	1	×	×	×	GLED[4:0]				
									0	0	0	0	0	0	0	
04h	0	0	0	0	0	1	0	0	×	×	×	BLED[4:0]				
									0	0	0	0	0	0	0	
05h	0	0	0	0	0	1	0	1	×	B2ON	G2ON	R2ON	×	B1ON	G1ON	R1ON
									0	0	0	0	0	0	0	
06h	0	0	0	0	0	1	1	0	×	B4ON	G4ON	R4ON	×	B3ON	G3ON	R3ON
									0	0	0	0	0	0	0	
07h	0	0	0	0	0	1	1	1	×	B6ON	G6ON	R6ON	×	B5ON	G5ON	R5ON
									0	0	0	0	0	0	0	
08h	0	0	0	0	1	0	0	0	×	B8ON	G8ON	R8ON	×	B7ON	G7ON	R7ON
									0	0	0	0	0	0	0	
09h	0	0	0	0	1	0	0	1	R7PON[1:0]		R5PON[1:0]		R3PON[1:0]		R1PON[2:0]	
									0	0	0	0	0	0	0	0
0ah	0	0	0	0	1	0	1	0	R8PON[1:0]		R6PON[1:0]		R4PON[1:0]		R2PON[1:0]	
									0	0	0	0	0	0	0	0
0bh	0	0	0	0	1	0	1	1	G7PON[1:0]		G5PON[1:0]		G3PON[1:0]		G1PON[1:0]	
									0	0	0	0	0	0	0	0
0ch	0	0	0	0	1	1	0	0	G8PON[1:0]		G6PON[1:0]		G4PON[1:0]		G2PON[1:0]	
									0	0	0	0	0	0	0	0
0dh	0	0	0	0	1	1	0	1	B7PON[1:0]		B5PON[1:0]		B3PON[1:0]		B1PON[1:0]	
									0	0	0	0	0	0	0	0
0eh	0	0	0	0	1	1	1	0	B8PON[1:0]		B6PON[1:0]		B4PON[1:0]		B2PON[1:0]	
									0	0	0	0	0	0	0	0
0fh	0	0	0	0	1	1	1	1	R8FD	R7FD	R6FD	R5FD	R4FD	R3FD	R2FD	R1FD
									0	0	0	0	0	0	0	0
10h	0	0	0	1	0	0	0	0	G8FD	G7FD	G6FD	G5FD	G4FD	G3FD	G2FD	G1FD
									0	0	0	0	0	0	0	0
11h	0	0	0	1	0	0	0	1	B8FD	B7FD	B6FD	B5FD	B4FD	B3FD	B2FD	B1FD
									0	0	0	0	0	0	0	0
12h	0	0	0	1	0	0	1	0	R8CM	R7CM	R6CM	R5CM	R4CM	R3CM	R2CM	R1CM
									0	0	0	0	0	0	0	0
13h	0	0	0	1	0	0	1	1	G8CM	G7CM	G6CM	G5CM	G4CM	G3CM	G2CM	G1CM
									0	0	0	0	0	0	0	0
14h	0	0	0	1	0	1	0	0	B8CM	B7CM	B6CM	B5CM	B4CM	B3CM	B2CM	B1CM
									0	0	0	0	0	0	0	0
15h	0	0	0	1	0	1	0	1	R1PWM[7:0]							
									0	0	0	0	0	0	0	0
16h	0	0	0	1	0	1	1	0	G1PWM[7:0]							
									0	0	0	0	0	0	0	0
17h	0	0	0	1	0	1	1	1	B1PWM[7:0]							
									0	0	0	0	0	0	0	0
18h	0	0	0	1	1	0	0	0	R2PWM[7:0]							
									0	0	0	0	0	0	0	0
19h	0	0	0	1	1	0	0	1	G2PWM[7:0]							
									0	0	0	0	0	0	0	0
1ah	0	0	0	1	1	0	1	0	B2PWM[7:0]							
									0	0	0	0	0	0	0	0
Register address									Data							

Continued on next page.

LV5236V

Continued from preceding page.

	A7	A6	A5	A4	A3	A2	A1	A0	D7	D6	D5	D4	D3	D2	D1	D0
1bh	0	0	0	1	1	0	1	1	R3PWM[7:0]							
									0	0	0	0	0	0	0	0
1ch	0	0	0	1	1	1	0	0	G3PWM[7:0]							
									0	0	0	0	0	0	0	0
1dh	0	0	0	1	1	1	0	1	B3PWM[7:0]							
									0	0	0	0	0	0	0	0
1eh	0	0	0	1	1	1	1	0	R4PWM[7:0]							
									0	0	0	0	0	0	0	0
1fh	0	0	0	1	1	1	1	1	G4PWM[7:0]							
									0	0	0	0	0	0	0	0
20h	0	0	1	0	0	0	0	0	B4PWM[7:0]							
									0	0	0	0	0	0	0	0
21h	0	0	1	0	0	0	0	1	R5PWM[7:0]							
									0	0	0	0	0	0	0	0
22h	0	0	1	0	0	0	1	0	G5PWM[7:0]							
									0	0	0	0	0	0	0	0
23h	0	0	1	0	0	0	1	1	B5PWM[7:0]							
									0	0	0	0	0	0	0	0
24h	0	0	1	0	0	1	0	0	R6PWM[7:0]							
									0	0	0	0	0	0	0	0
25h	0	0	1	0	0	1	0	1	G6PWM[7:0]							
									0	0	0	0	0	0	0	0
26h	0	0	1	0	0	1	1	0	B6PWM[7:0]							
									0	0	0	0	0	0	0	0
27h	0	0	1	0	0	1	1	1	R7PWM[7:0]							
									0	0	0	0	0	0	0	0
28h	0	0	1	0	1	0	0	0	G7PWM[7:0]							
									0	0	0	0	0	0	0	0
29h	0	0	1	0	1	0	0	1	B7PWM[7:0]							
									0	0	0	0	0	0	0	0
2ah	0	0	1	0	1	0	1	0	R8PWM[7:0]							
									0	0	0	0	0	0	0	0
2bh	0	0	1	0	1	0	1	1	G8PWM[7:0]							
									0	0	0	0	0	0	0	0
2ch	0	0	1	0	1	1	0	0	B8PWM[7:0]							
									0	0	0	0	0	0	0	0
Register address									Data							

- SANYO Semiconductor Co.,Ltd. assumes no responsibility for equipment failures that result from using products at values that exceed, even momentarily, rated values (such as maximum ratings, operating condition ranges, or other parameters) listed in products specifications of any and all SANYO Semiconductor Co.,Ltd. products described or contained herein.
- SANYO Semiconductor Co.,Ltd. strives to supply high-quality high-reliability products, however, any and all semiconductor products fail or malfunction with some probability. It is possible that these probabilistic failures or malfunction could give rise to accidents or events that could endanger human lives, trouble that could give rise to smoke or fire, or accidents that could cause damage to other property. When designing equipment, adopt safety measures so that these kinds of accidents or events cannot occur. Such measures include but are not limited to protective circuits and error prevention circuits for safe design, redundant design, and structural design.
- In the event that any or all SANYO Semiconductor Co.,Ltd. products described or contained herein are controlled under any of applicable local export control laws and regulations, such products may require the export license from the authorities concerned in accordance with the above law.
- No part of this publication may be reproduced or transmitted in any form or by any means, electronic or mechanical, including photocopying and recording, or any information storage or retrieval system, or otherwise, without the prior written consent of SANYO Semiconductor Co.,Ltd.
- Any and all information described or contained herein are subject to change without notice due to product/technology improvement, etc. When designing equipment, refer to the "Delivery Specification" for the SANYO Semiconductor Co.,Ltd. product that you intend to use.
- Upon using the technical information or products described herein, neither warranty nor license shall be granted with regard to intellectual property rights or any other rights of SANYO Semiconductor Co.,Ltd. or any third party. SANYO Semiconductor Co.,Ltd. shall not be liable for any claim or suits with regard to a third party's intellectual property rights which has resulted from the use of the technical information and products mentioned above.

This catalog provides information as of August, 2011. Specifications and information herein are subject to change without notice.